

Both the straight exit and the 90° exit die cast RFI/EMI shield allows cable to be fully prepared and terminated to the connector before the shield is installed. During installation, the shield of the jacketed cable is folded back and compressed into the cable opening of the RFI/EMI shield. For greater cable support and/or shielding effectiveness, splitting and crimp ferrules are available (pages 143-145).

Material and Finish:

Shield—Zinc alloy, plated nickel over copper

4-40 Pan Head Screws & Latch Screws (90° Exit Only)—Steel, zinc plated

One-Piece Slide Latch (90° Exit Only)—Stainless steel

Related Product Data:

Ferrules—pages 143-145

Connectors used with:

HDE Metal-Shell—pages 114 & 115

HDP Metal-Shell (Tin plated only)—pages 90-102

Technical Documents:

Product Specification—108-40032

Instruction Sheet—408-6769

Shielded Cable Clamps (Continued)

Straight Exit RFI/EMI Die Cast Shield for Jacketed Cable (Two-Piece)

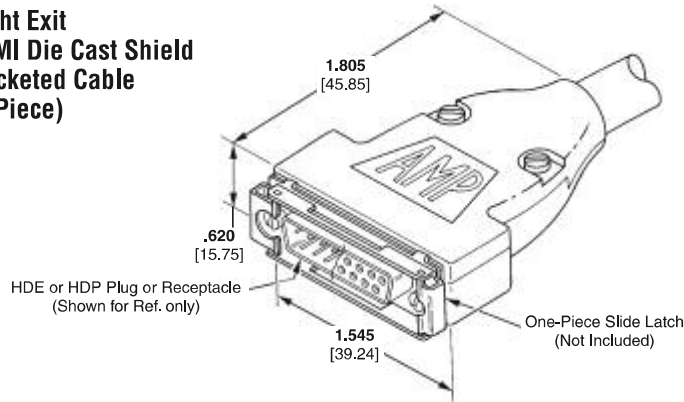

Shell Size	No. of Positions	ID Letter	Cable Dia. w/Ferrules	Part Number	Grommet Kit
2	15	E	.260-.300 6.60-7.72	5745919-3	—
		H	.190-.375 4.83-9.53	5745919-2	747746-1*
		K	.190-.430 4.83-10.92	5745919-1	—

*Cable Dia. Range using Grommet is .185-.320 [4.70-8.13].

- Notes:**
1. All parts packaged unassembled.
 2. Each kit comprised of a two-piece shield with 2 pan head screws.
 3. Split-ring and crimp ferrules are shown on pages 143-145.

90° Exit RFI/EMI Die Cast Shields for Jacketed Cable (Two-Piece)

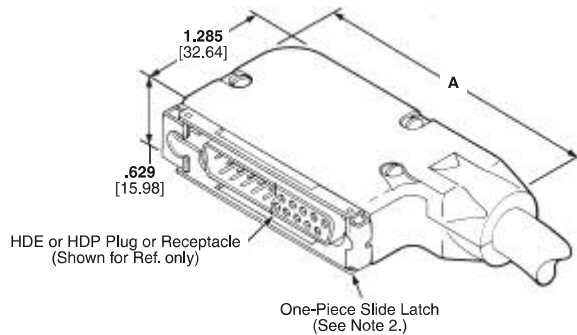

Shell Size	Dimension A	Cable Dia. w/Ferrules	Shield with Slide Latch Kit Numbers (See Note 2)	Shield without Slide Latch Kit Numbers (See Note 3)	Grommet Kit
2	2.310 58.67	.185-.225 4.70-6.48	5745652-4	—	—
		.260-.300 6.60-7.62	5745652-3	—	—
		.190-.375 4.83-9.53	5745652-2*	—	747746-1
		.190-.430 4.83-10.92	5745652-1	—	—
		.240-.280 6.10-7.11	5745653-5	—	—
3	2.850 72.39	.315-.355 8.00-9.02	5745653-4	—	—
		.190-.430 4.83-10.92	5745653-3	5747194-3	—
		.440-.480 11.18-12.19	5745653-2	—	—
		.380-.530 9.65-13.46	5745653-1*	—	747973-1

* Cable Dia. with Grommet Kit: Size 2 = .185-.320 [4.70-8.13]; Size 3 = .255-.470 [6.48-11.94].

- Notes:**
1. All parts are packaged unassembled.
 2. Each kit is comprised of a two-piece shield with three pan head screws and a slide latch with two 4-40 slide latch screws.
 3. Each kit is comprised of a two-piece shield with three pan head screws.
 4. Split-ring and crimp ferrules are shown on pages 143-145.

Note: All part numbers are RoHS compliant.