



Designers' Choice

COIN CELL PC BATTERY HOLDERS

20mm to 30mm Sizes



SINGLE CELL HOLDER
(3-VOLT)

DUAL CELL HOLDER
(6-VOLT)

Single and Dual "Printed Circuit" Cell Holders for Lithium Coin Cells. Designed for easy battery replacement. Will accommodate diameters from 12mm to 30mm and heights from 1.6mm to 7.7mm. Some holders will accept more than two cells if they fall within the heights specified.

IDEALLY SUITED FOR...

- Duracell, Eveready, Panasonic, Ray-O-Vac, Sanyo, Varta, Toshiba, Seiko and other major battery manufacturers
- Computer memory, power transfer and back-up systems
- Video and telecommunications power back-up
- Preprogrammed video and electronic games
- Microprocessors and Microcomputer memory hold
- Notebook and laptop applications
- Emergency power systems
- Industrial and commercial security and alarm systems
- Communications power sources
- Miniaturized battery power devices

DESIGN ADVANTAGES...

- Low profile for high density packaging
- Reliable spring tension assures low contact resistance
- Retains battery securely to withstand shock and vibration
- Unique notched slots assure quick and easy battery insertion and replacement
- Base material UL Rated 94V-0. Impervious to most industrial solvents
- Operating temperature range: -60°F to +293°F (-50°C to +145°C)
- Advanced air-flow design pattern enhances air circulation around battery
- Nickel-over-copper plated spring steel contacts feature clearly marked polarities to help guard against improper insertion

12mm to 16mm & 1/3 "N" Sizes

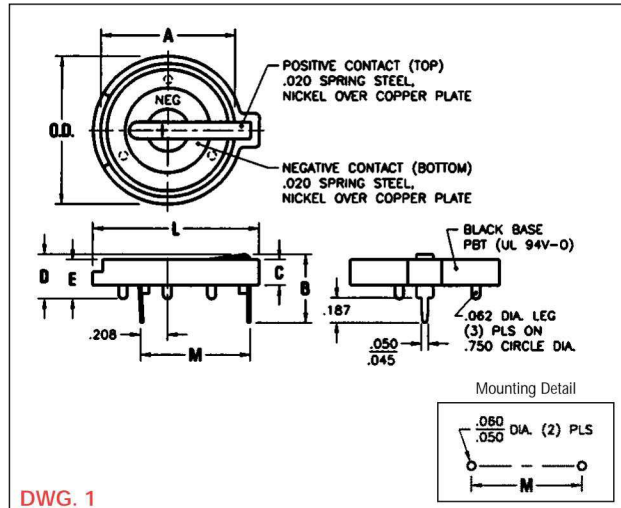
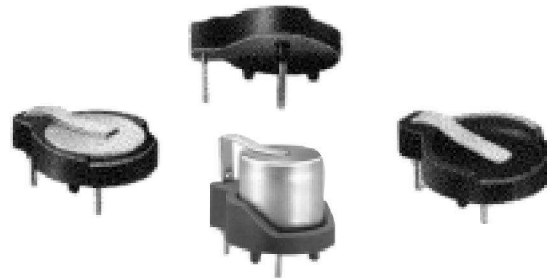

DWG. 1

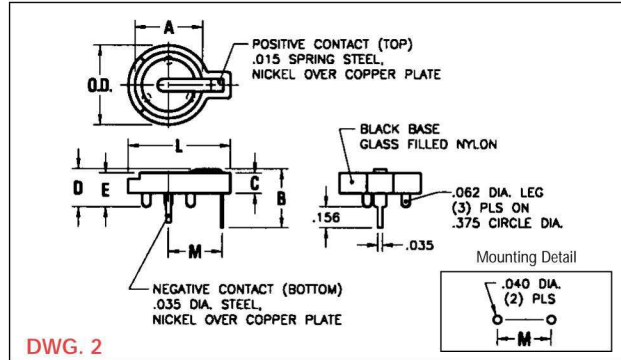

DWG. 2

CAT. NO.	DWG. NO.	NO. OF CELLS	DIMENSIONS								BATTERY CROSS REFERENCE	
			A	B	C	D	E	L	O.D.	M	CELL	DURACELL, EVEREADY, PANASONIC, RAY-O-VAC SANYO, SONY, SEIKO, TOSHIBA, VARTA
499	2	1	.495	.695	.250	.580	.350	.750	.593	.393	"1/3N"	DL 1/3N, K58L, CR 1/3N
500	2	1	.495	.435	.150	.280	.250	.750	.593	.393	12mm	BR1216, CR1216, BR1220, CL1220, CR1220, BR1225
501	2	2	.495	.505	.250	.380	.350	.750	.593	.393	16mm	BR1616, CR1612, CR1616, CR1620, CR1632
502	2	1	.635	.505	.150	.312	.250	.897	.750	.463	16mm	BR1616, CR1612, CR1616, CR1620, CR1632
103	1	1	.796	.513	.195	.335	.295	1.130	.896	.807	20mm	BR2016, CR2016, DL2016, BR2020, CL2020, BR2025, CR2025, DL2025, BR2032, CR2032, DL2032
106	1	1	.796	.513	.195	.335	.295	1.219	1.093	.807	20mm	BR2016, CR2016, DL2016, BR2020, CL2020, BR2025, CR2025, DL2025, BR2032, CR2032, DL2032
1026	1	2	.796	.630	.312	.452	.412	1.219	1.093	.807	23mm	BR2320, CL2320, CR2320, BR2325, CR2325, DL2325, BR2330, CL2330, BR2335, CR2335**
104	1	1	.911	.513	.195	.335	.295	1.150	1.000	.807	23mm	BR2320, CL2320, CR2320, BR2325, CR2325, DL2325, BR2330, CL2330, BR2335, CR2335**
107	1	1	.911	.513	.195	.335	.295	1.219	1.093	.807	23mm	BR2320, CL2320, CR2320, BR2325, CR2325, DL2325, BR2330, CL2330, BR2335, CR2335**
1027	1	2	.911	.630	.312	.452	.412	1.219	1.093	.807	24mm	CR2430, DL2430, CR2450*, DL2450*, CR2477†
105	1	1	.985	.513	.195	.335	.295	1.219	1.093	.807	24mm	CR2430, DL2430, CR2450*, DL2450*, CR2477†
1025	1	2	.985	.630	.312	.452	.412	1.219	1.093	.807	24mm	CR2430, DL2430, CR2450*, DL2450*, CR2477†
1025-7	1	1	.985	.681	.312	.503	.412	1.219	1.093	.807	24mm	CR2430, DL2430, CR2450*, DL2450*, CR2477†
301	1	1	1.187	.513	.195	.335	.295	1.425	1.297	.807	30mm	BR3032

* For Cat. No. 1025 (1) cell only. ** For Cat. No. 1027 (1) cell only. † For Cat. No. 1025-7 only.