

Sales Outline Drawing

Specifications:

Designed to meet Medical Spec

Sound Level Category:	Loud	Loud	Loud
Mode of Operation:	Low Priority Alarm 2 beeps repeating every 30 sec	Medium Priority Alarm 3 beeps repeating every 7.5 sec	High Priority Alarm 10 beeps repeating every 2.5 seconds
Loudness @ 10cm:	85 to 95 dB(A) Typ.	85 to 95 dB(A) Typ.	85 to 95 dB(A) Typ.
Frequency:	150 to 4000 Hz		
Connection:	Connect "+" to "+" & "-" to "-" of Power Supply	Connect "+" to "+" & "-" & Medium to "-" of Power Supply	Connect "+" to "+" & "-" & High to "-" of Power Supply
Voltage Rating:	5 ± 0.5 VDC		
Average Current Draw:	<45mA Typ.	<70mA Typ.	<150mA Typ.
Ipk Current*:	400mA		
Housing Material:	Valox (UL94V-0), Octagonal, Black		
Storage Temperature:	-30° to +60° C		
Operating Temperature:	-30° to +55° C		
Weight (Typical):	6.0g		
Options:	Please contact factory.		

Dimensions: Inches [mm]

ROHS Compliant

PATENT NUMBER: 7880593

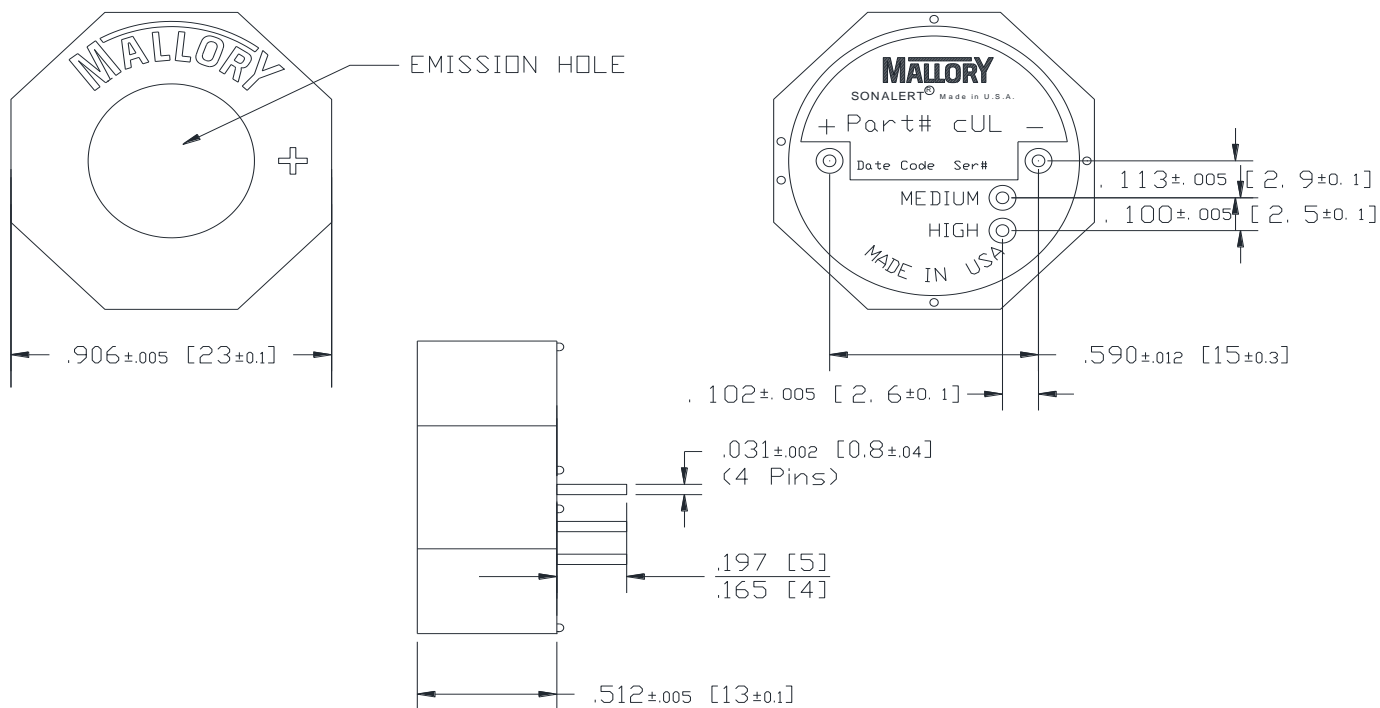

NOTE A:
TERMINALS - .031" DIA. NICKEL/TIN COATED BRASS.

NOTE B:
MOUNTING- INSERT INTO PRINTED CIRCUIT BOARD AND HAND OR MACHINE SOLDER.
UNITS ARE SUITABLE FOR WAVE SOLDERING. BOARDS ARE NOT SUITABLE FOR WASH.
RECOMMENDED MAXIMUM TEMPERATURE AND TIME DURATION FOR WAVE SOLDERING IS
+270°C AND 3 SECONDS RESPECTIVELY.

*Ipk = Instantaneous Peak