

35-75V Continuous Input	100V Transient Input	12Vout Semi-Regulated	300W Max Power	2250V dc Isolation	Quarter-brick DC-DC Converter
-----------------------------------	--------------------------------	---------------------------------	--------------------------	------------------------------	---

The SQ60120QEx25 bus converter is a next-generation, board-mountable, isolated, fixed switching frequency dc/dc converter that uses synchronous rectification to achieve extremely high conversion efficiency. The power dissipated by the converter is so low that a heatsink is not required, which saves cost, weight, height, and application effort. The SQ BusQor® series provides an isolated step down voltage from 48V to a semi-regulated 12V intermediate bus. BusQor converters are ideal for customers who need multiple outputs and wish to build or buy point of load converters to work with a 12V rail. RoHS Compliant (see last page).

BusQor®

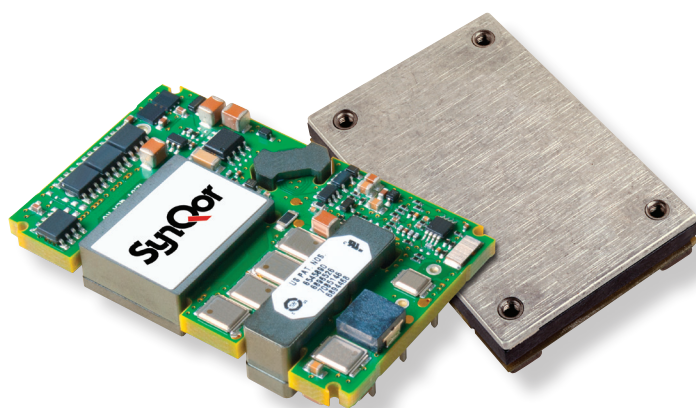

SQ60120QEx25 Model

Operational Features

- High efficiency, 96% at full rated load current
- Delivers 25A (300W) power with minimal derating - no heatsink required
- Operating input voltage range: 35-75Vdc
- Fixed frequency switching provides predictable EMI
- No minimum load requirement

Mechanical Features

- Industry standard pin-out configuration
- Standard Size Open Frame: 1.45 x 2.30" (36.8 x 58.4mm)
- Total Open Frame height only 0.417" (10.59mm), permits better airflow and smaller card pitch
- Open Frame Weight: 1.5 oz. (42g)
- Flanged pins designed to permit surface mount soldering (avoid wave solder) using FPIP technique

Safety Features

- UL 60950-1/R2011-12
- EN60950-1/A2:2013
- CAN/CSA-C22.2 No. 60950-1/A1:2011

Control Features

- On/Off control referenced to input side

Protection Features

- Input under-voltage lockout disables converter at low Vin conditions
- Output current limit and short circuit protection protects converter and load from permanent damage and hazardous conditions
- Active back bias limit provides smooth startup with external load induced pre-bias

Contents

	Page No.
Open Frame Mechanical Diagram	2
Baseplated Mechanical	3
Electrical Characteristics	4
Standards & Qualifications	6
Figures	7
Application Section	10
Ordering Information	14

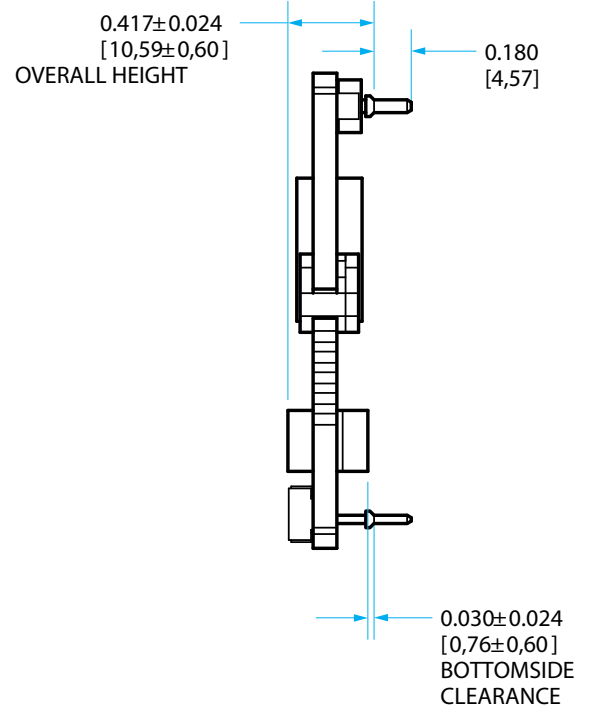
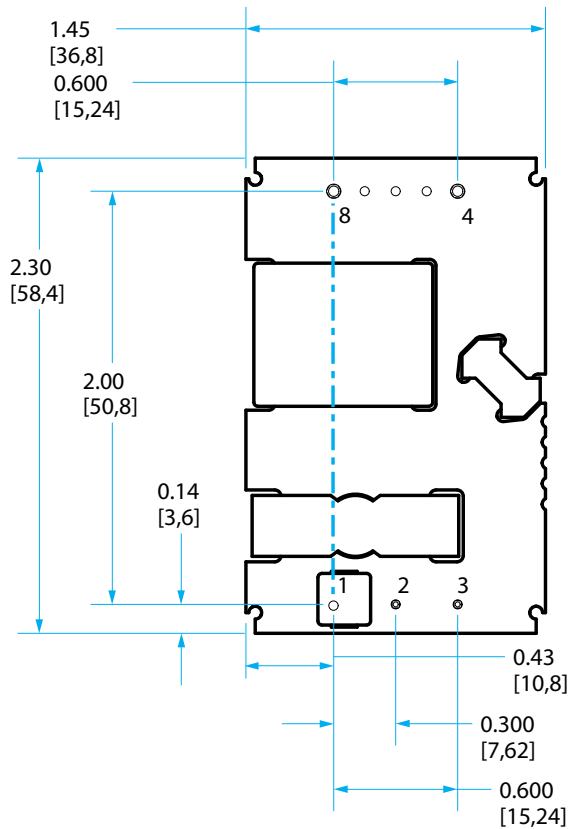

NOTES

- 1) Pins 1-3 are 0.040" (1.02mm) dia. with 0.080" (2.03mm) standoff shoulders.
- 2) Pins 4 & 8 are 0.062" (1.57mm) dia. with 0.100" (2.54mm) standoff shoulders.
- 3) Other pin extension lengths available.
- 4) All Pins: Material - Copper Alloy
Finish: Matte Tin over Nickel Plate
- 5) Undimensioned components are shown for visual reference only.
- 6) All dimensions in inches (mm)
Tolerances: X.XXin +/- 0.02 (X.Xmm +/- 0.5mm)
X.XXXin +/- 0.010 (X.XXmm +/- 0.25mm)
- 7) Open Frame Weight: 1.5 oz. (42g)
- 8) Workmanship: Meets or exceeds IPC-A-610 Class II

PIN DESIGNATIONS

Pin	Name	Function
1	Vin(+)	Positive input voltage
2	ON/OFF	TTL input to turn converter on and off, referenced to Vin(-), with internal pull up.
3	Vin(-)	Negative input voltage
4	Vout(-)	Negative output voltage
5	Not Present	Not applicable
6	Not Present	Not applicable
7	Not Present	Not applicable
8	Vout(+)	Positive output voltage

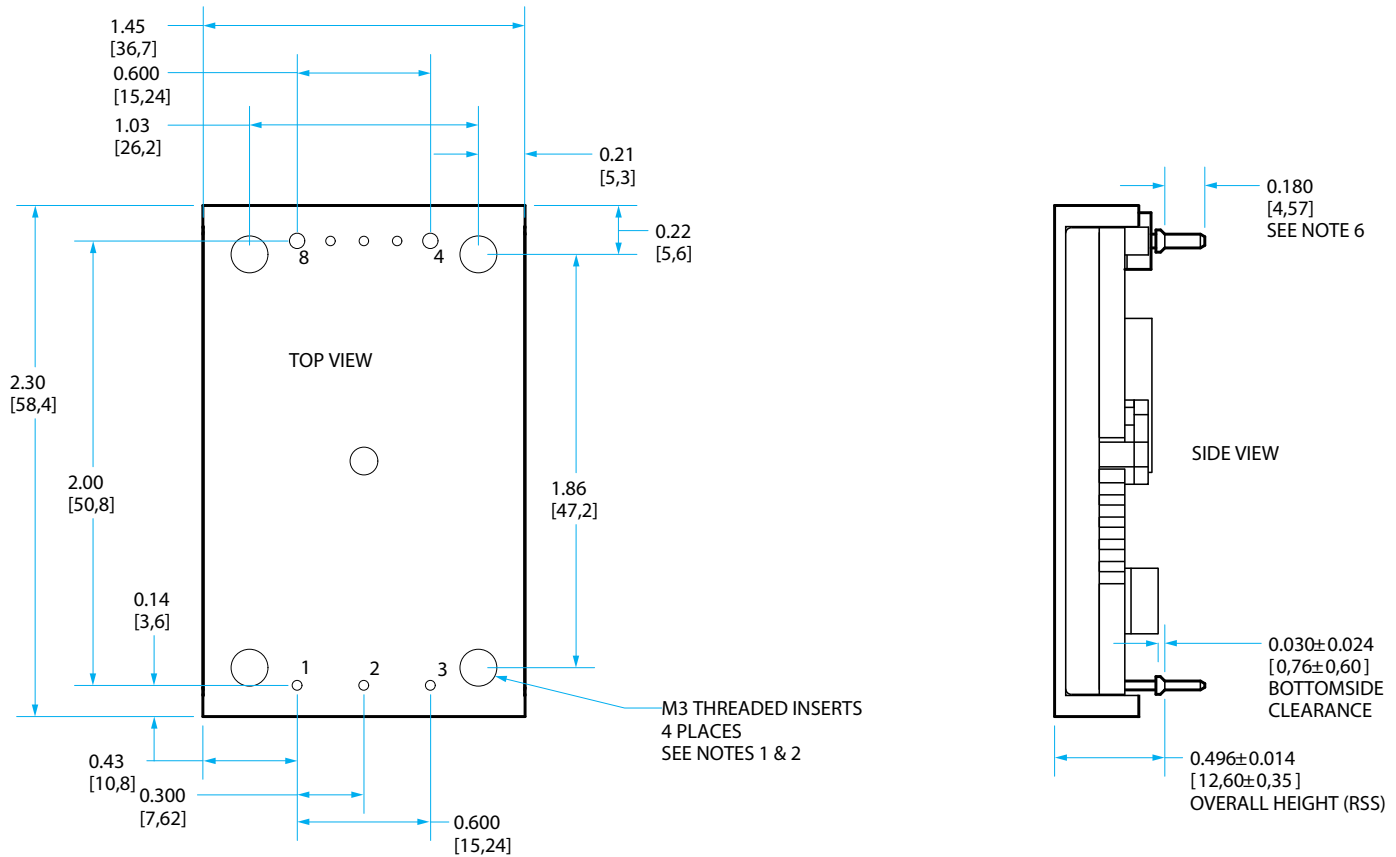

NOTES

- M3 screws used to bolt unit's baseplate to other surfaces such as heatsink must not exceed 0.100" (2.54mm) depth below the surface of the baseplate.
- Applied torque per screw should not exceed 6in-lb (0.7Nm).
- Baseplate flatness tolerance is 0.004" (.10mm) TIR for surface.
- Pins 1-3 are 0.040" (1.02mm) dia. with 0.080" (2.03mm) standoff shoulders.
- Pins 4 & 8 are 0.062" (1.57mm) dia. with 0.100" (2.54mm) standoff shoulders.
- Other pin extension lengths available.
- All Pins: Material - Copper Alloy
Finish: Matte Tin over Nickel Plate
- Undimensioned components are shown for visual reference only.
- All dimensions in inches (mm)
Tolerances: X.XXin +/- 0.02 (X.Xmm +/- 0.5mm)
X.XXXin +/- 0.010 (X.XXmm +/- 0.25mm)
- Weight: 1.6 oz. (46g)
- Workmanship: Meets or exceeds IPC-A-610 Class II

PIN DESIGNATIONS

Pin	Name	Function
1	Vin(+)	Positive input voltage
2	ON/OFF	TTL input to turn converter on and off, referenced to Vin(-), with internal pull up.
3	Vin(-)	Negative input voltage
4	Vout(-)	Negative output voltage
5	Not Present	Not applicable
6	Not Present	Not applicable
7	Not Present	Not applicable
8	Vout(+)	Positive output voltage

SQ60120QEx25 Electrical Characteristics

Ta = 25 °C, airflow rate = 300 LFM, Vin = 48 V dc unless otherwise noted; full operating temperature range is -40 °C to +100 °C baseplate temperature with appropriate power derating. Specifications subject to change without notice.

Parameter	Min.	Typ.	Max.	Units	Notes & Conditions
ABSOLUTE MAXIMUM RATINGS					
Input Voltage					
Non-Operating	-1		100	V	Continuous
Operating			80	V	Continuous
Operating Transient Protection			100	V	100 ms transient, square wave
Isolation Voltage					
Input to Output			2250	V	
Operating Temperature	-40		100	°C	
Storage Temperature	-45		125	°C	
Voltage at ON/OFF input pin	-2		18	V	
INPUT CHARACTERISTICS					
Operating Input Voltage Range	35	48	75	V	100 ms transient, square wave
Input Under-Voltage Lockout					
Turn-On Voltage Threshold	31.5	33.0	34.5	V	
Turn-Off Voltage Threshold	28.0	29.5	31.0	V	
Lockout Voltage Hysteresis	2.5	3.5	4.5	V	
Maximum Input Current			10	A	100% Load, 35 Vin
No-Load Input Current		70	100	mA	
Disabled Input Current		20	40	mA	
Inrush Current Transient Rating				A ² s	
Response to Input Transient		1.0		V	0.25V/μs input transient
Input Reflected-Ripple Current		5	10	mA	RMS thru 4.7μH inductor
Input Terminal-Ripple Current		60		mA	RMS
Recommended Input Fuse			15	A	Fast blow external fuse recommended
Recommended External Input Capacitance		100		μF	Typical ESR 0.1-0.2 Ω; Figure 11
Input Filter Component Values (C\L\C)		22\1.5\6		nF\μH\μF	Internal values; Figure H
OUTPUT CHARACTERISTICS					
Output Voltage Set Point	12.00	12.20	12.35	V	Vin = 65 V, no load, Ta = 25 °C
Output Voltage Regulation					
Over Line		-1.5/180		V	
Over Load		-4.5/540		mV	
Over Temperature		±1.5/180		mV	
Total Output Voltage Range	11.0		12.6	V	Over sample, line, load, temperature & life
Output Voltage Ripple and Noise					
Peak-to-Peak		50	100	mV	Full load
RMS		10	40	mV	Full load
Operating Output Current Range	0		25	A	Subject to thermal derating
Output DC Current-Limit Inception	27.0	32.0	37.0	A	Output Voltage 10% Low
Output DC Current-Limit Shutdown Voltage		5		V	See Note 2
Back-Drive Current Limit while Enabled	13	18	23	A	Negative current drawn from output source
Back-Drive Current Limit while Disabled	0	0.5	1.0	mA	Negative current drawn from output
Maximum Output Capacitance			12	mF	Nominal Vout at full load (resistive load)
EFFICIENCY					
100% Load	95.5	96		%	Figures 1 - 2
50% Load		97		%	Figures 1 - 2

SQ60120QEx25 Electrical Characteristics (continued)

Ta = 25 °C, airflow rate = 300 LFM, Vin = 48 V dc unless otherwise noted; full operating temperature range is -40 °C to +100 °C baseplate temperature with appropriate power derating. Specifications subject to change without notice.

Parameter	Min.	Typ.	Max.	Units	Notes & Conditions
DYNAMIC CHARACTERISTICS					
Output Voltage during Load Current Transient					
Step Change in Output Current (0.1A/μs)		350		mV	50% to 75% to 50% Iout max, 470 μF load cap
Step Change in Output Current (5A/μs)		350		mV	
Settling time		1		ms	To within 1% Vout nom
Turn-On Transient					
Turn-On Time		25		ms	Full load, Vout=90% nom; Figures 9 & 10
Output Voltage Overshoot		2		%	12 mF load capacitance, Iout = 0A
ISOLATION CHARACTERISTICS					
Isolation Voltage (dielectric strength)			2250	V	See Absolute Maximum Ratings
Isolation Resistance		30		MΩ	
Isolation Capacitance (input to output)		1000		pF	See note 3
TEMPERATURE LIMITS FOR POWER DERATING CURVES					
Semiconductor Junction Temperature			125	°C	Package rated to 150°C
Board Temperature			125	°C	UL rated max operating temp 130°C
Transformer Temperature			125	°C	
FEATURE CHARACTERISTICS					
Switching Frequency Regulation Stage	235.5	238.0	240.5	kHz	Over sample, temp & life
Switching Frequency Isolation Stage	117.75	119.00	120.25	kHz	Over sample, temp & life
ON/OFF Control (Option P)					
Off-State Voltage	-2.0		1.0	V	
On-State Voltage	4.0		18.0		
ON/OFF Control (Option N)					
Off-State Voltage	4.0		18.0	V	
On-State Voltage	-2.0		1.0		
ON/OFF Control (Either Option)					Application notes; Figure A
ON/OFF Control Hysteresis		1.5		°C	
Pull-Up Voltage	4.75	5.00	5.25	V	
Pull-Up Resistance		10		kΩ	
Output Over-Voltage Protection	113	118	123	%	Over Full Temperature Range; % of nominal Vout
Over-Temperature Shutdown		120		°C	Average PCB Temperature
Over-Temperature Shutdown Restart Hysteresis		10		°C	
RELIABILITY CHARACTERISTICS					
Calculated MTBF (Telcordia)		2.1		10 ⁶ Hrs.	TR-NWT-000332; 80% load, 300LFM, 40°C Ta
Calculated MTBF (MIL-217)		1.9		10 ⁶ Hrs.	MIL-HDBK-217F; 80% load, 300LFM, 40°C Ta
Field Demonstrated MTBF				10 ⁶ Hrs.	See our website for details

Note 1: For applications requiring reduced output voltage ripple and noise, consult SynQor applications support (e-mail: support@synqor.com)

Note 2: If the output voltage falls below the Output DC Current Limit Shutdown Voltage for more than 50ms, then the unit will enter into hiccup mode, with a 500ms off-time.

Note 3: Higher values of isolation capacitance can be added external to the module.



Technical Specification

Input:35-75V
Output:12V
Current:25A
Part No.:SQ60120QEx25

Standards Compliance & Qualification Testing

Parameter	Notes & Conditions
STANDARDS COMPLIANCE	
UL 60950-1/R2011-12	Basic insulation
EN60950-1/A2:2013	
CAN/CSA-C22.2 No. 60950-1/A1:2011	

Note: An external input fuse must always be used to meet these safety requirements. Contact SynQor for official safety certificates on new releases or download from the SynQor website.

Parameter	# Units	Test Conditions
QUALIFICATION TESTING		
Life Test	32	95% rated Vin and load, units at derating point, 1000 hours
Vibration	5	10-55 Hz sweep, 0.060" total excursion, 1 min./sweep, 120 sweeps for 3 axis
Mechanical Shock	5	100g minimum, 2 drops in x, y and z axis
Temperature Cycling	10	-40 °C to 100 °C, unit temp. ramp 15 °C/min., 500 cycles
Power/Thermal Cycling	5	Toperating = min to max, Vin = min to max, full load, 100 cycles
Design Marginality	5	Tmin-10 °C to Tmax+10 °C, 5 °C steps, Vin = min to max, 0-105% load
Humidity	5	85 °C, 95% RH, 1000 hours, continuous Vin applied except 5 min/day
Solderability	15 pins	MIL-STD-883, method 2003

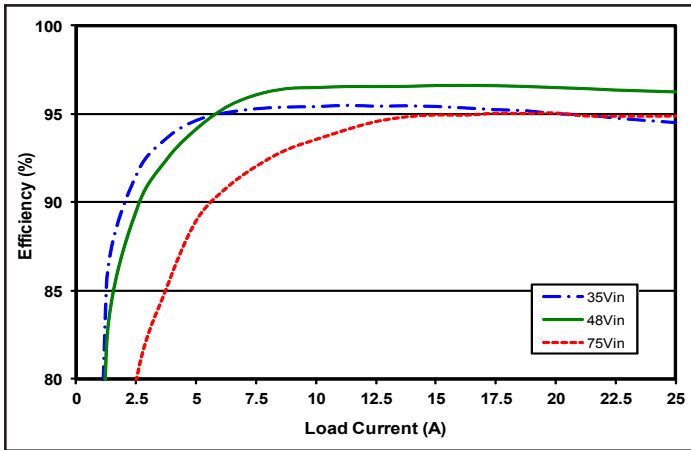

Figure 1: Efficiency at nominal output voltage vs. load current for minimum, nominal, and maximum input voltage at 25°C.

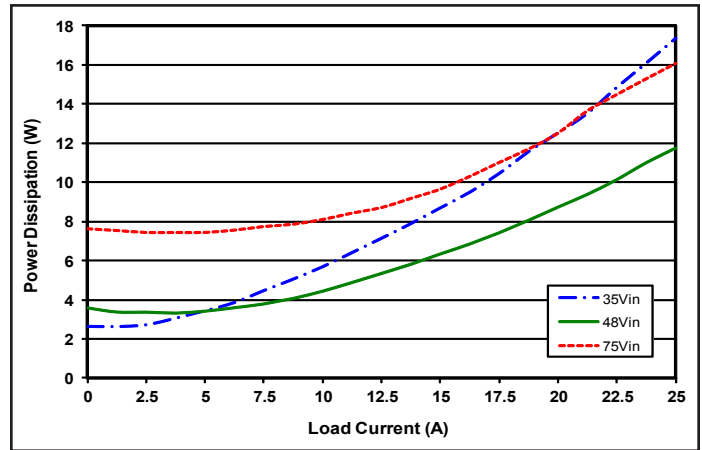

Figure 2: Power dissipation at nominal output voltage vs. load current for minimum, nominal, and maximum input voltage at 25°C.

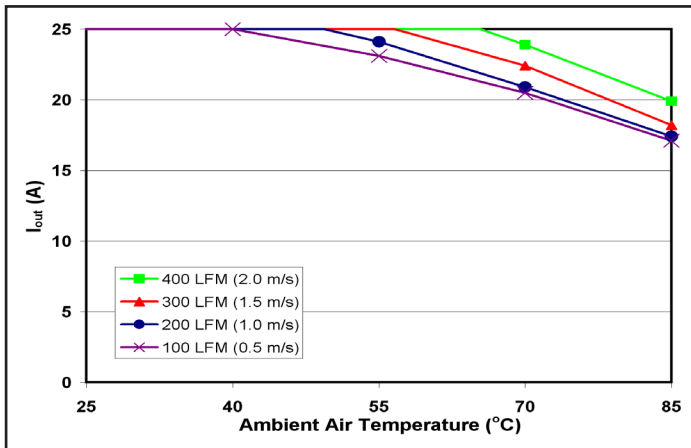

Figure 3: Maximum output power derating curves vs. ambient air temperature for airflow rates of 100 LFM through 400 LFM with air flowing across the converter from pin 1 to pin 3 (nominal input voltage).

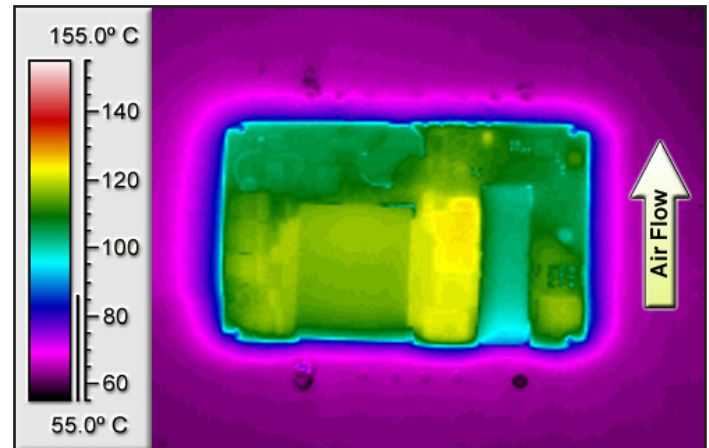

Figure 4: Thermal plot of converter at 24A load current (288W) with 55°C air flowing at the rate of 200 LFM. Air is flowing across the converter sideways from pin 1 to pin 3 (nominal input voltage).

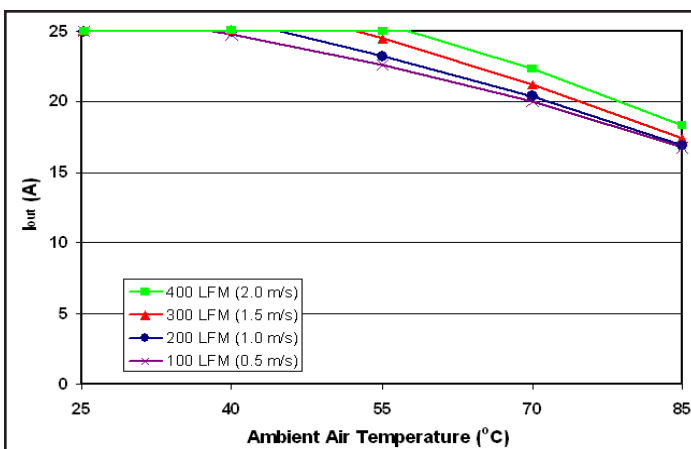

Figure 5: Maximum output power derating curves vs. ambient air temperature for airflow rates of 100 LFM through 400 LFM with air flowing lengthwise from input to output (nominal input voltage).

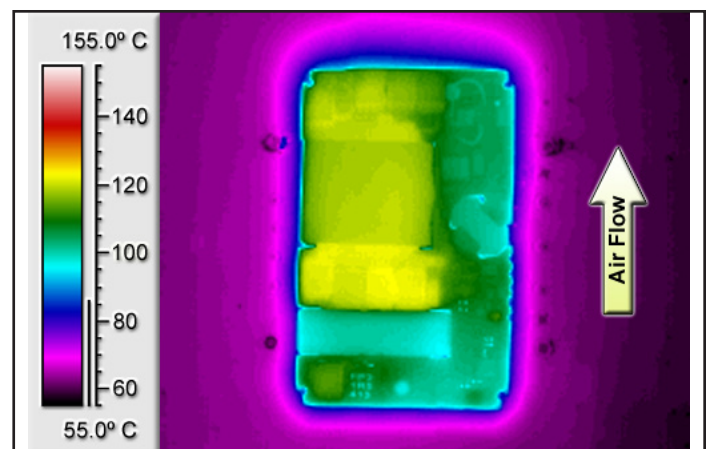

Figure 6: Thermal plot of converter at 23A load current (276W) with 55°C air flowing at the rate of 200 LFM. Air is flowing across the converter from input to output (nominal input voltage).

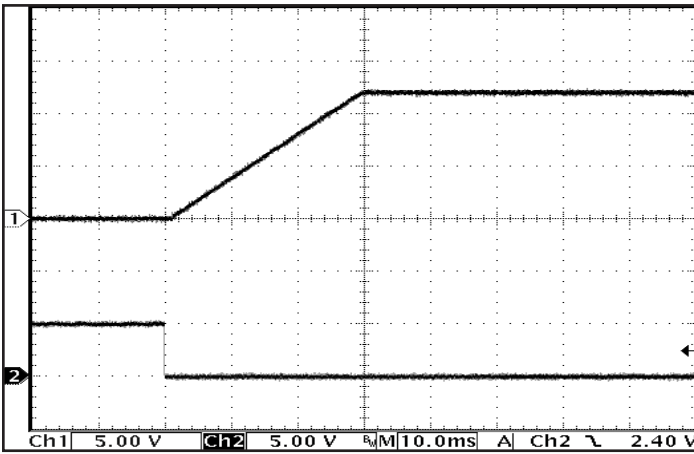

Figure 7: Turn-on transient at full load (resistive load) (10 ms/div).
 Ch 1: Vout (5V/div)
 Ch 2: ON/OFF input (5V/div)

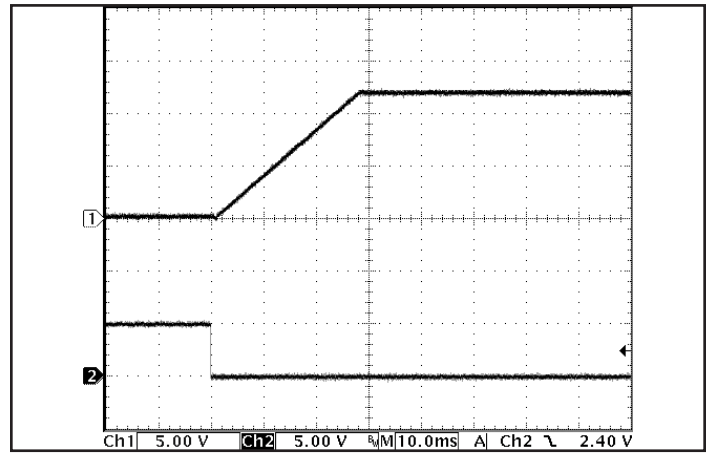

Figure 8: Turn-on transient at zero load (10 ms/div).
 Ch 1: Vout (5V/div)
 Ch 2: ON/OFF input (5V/div)

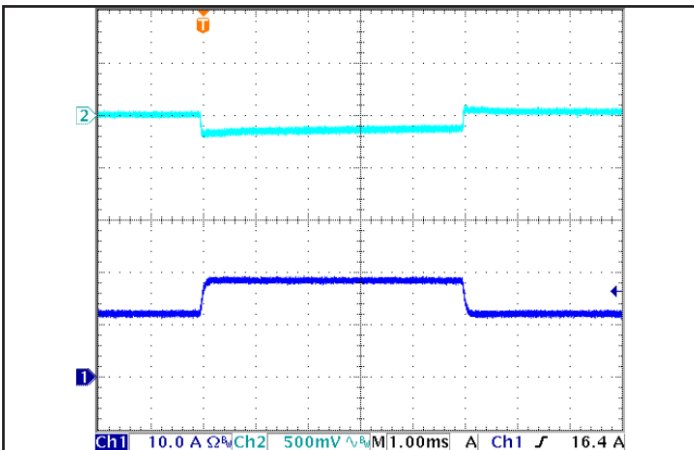

Figure 9: Output voltage response to step-change in load current [50%-75%-50% of $I_{out(max)}$; $dI/dt = 0.1A/\mu s$]. Load cap: 1 μF ceramic and 10 μF tantalum capacitors. Top trace: Vout (500mV/div), Bottom trace: Iout (10A/div).

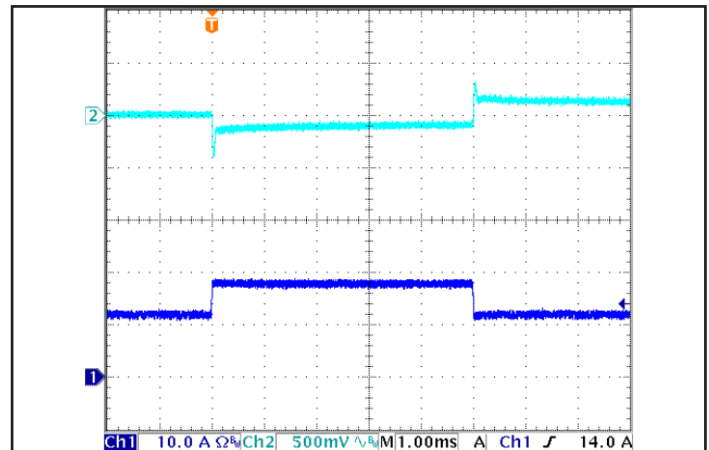

Figure 10: Output voltage response to step-change in load current [50%-75%-50% of $I_{out(max)}$; $dI/dt = 5A/\mu s$]. Load cap: 470 μF , 15 m Ω ESR tantalum capacitor. Top trace: Vout (500mV/div), Bottom trace: Iout (10A/div).

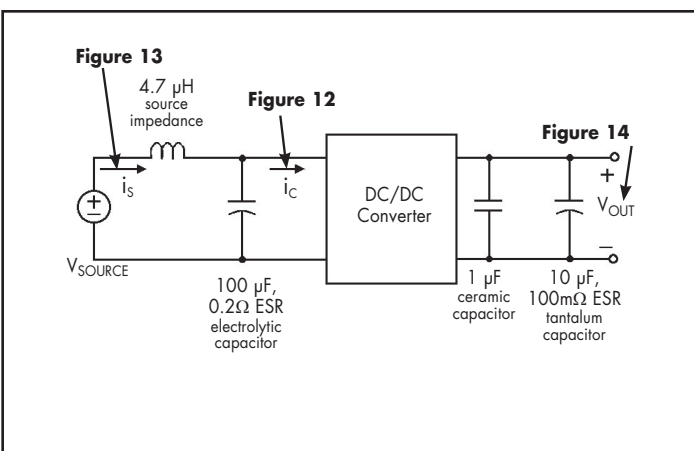

Figure 11: Test set-up diagram showing measurement points for Input Terminal Ripple Current (Figure 12), Input Reflected Ripple Current (Figure 13) and Output Voltage Ripple (Figure 14).

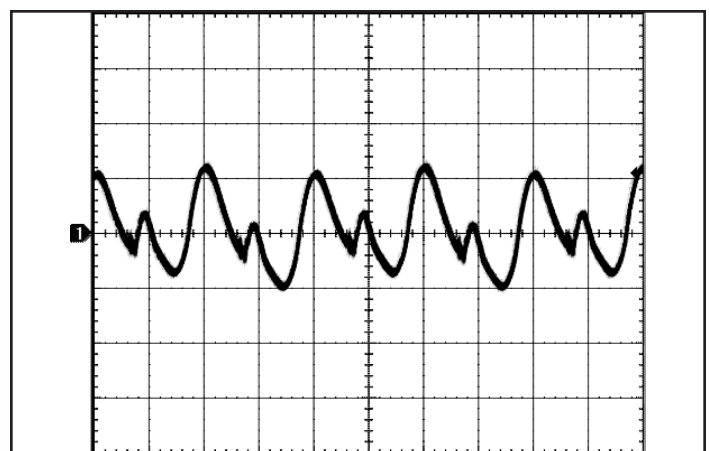

Figure 12: Input Terminal Ripple Current, i_c , at full rated output current and nominal input voltage with 4.7 μH source impedance and 100 μF electrolytic capacitor (100 mA/div). See Figure 11.

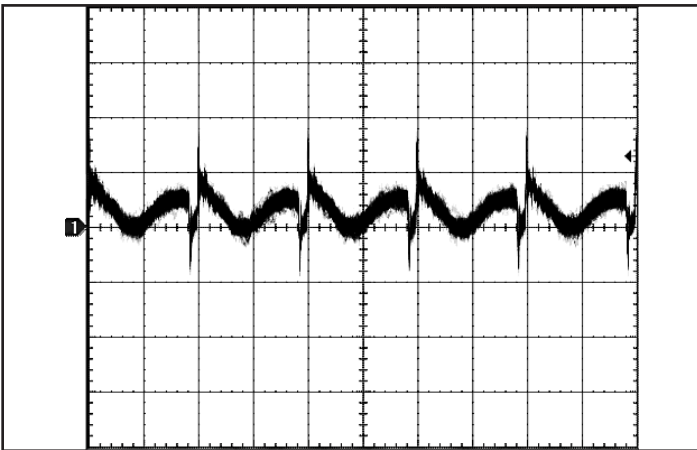

Figure 13: Input reflected ripple current, is, through a 4.7 μ H source inductor, using a 100 μ F input capacitor, at nominal input voltage and rated load current (10 mA/div). See Figure 11.

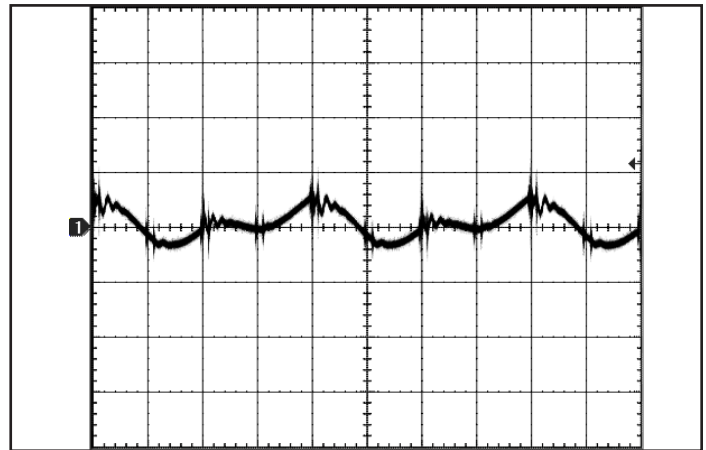

Figure 14: Output voltage ripple at nominal input voltage and rated load current (20 mV/div). Load capacitance: 1 μ F ceramic capacitor and 10 μ F tantalum capacitor. Bandwidth: 500 MHz. See Figure 11.

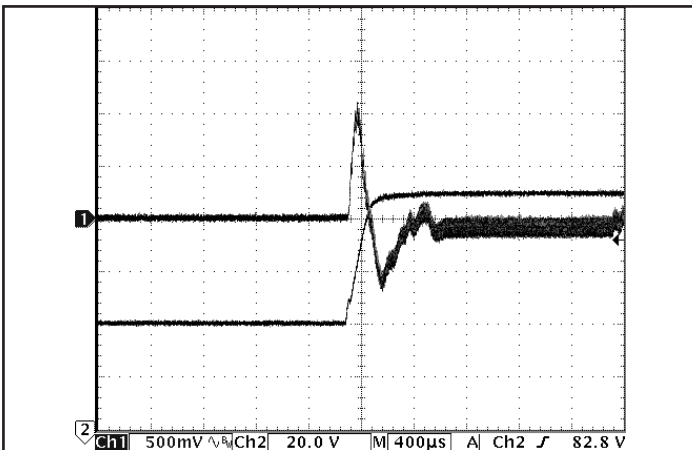

Figure 15: Output voltage response to step-change in input voltage (50V to 100V in 200 μ s). Load cap: 470 μ F, 15 mW ESR tantalum capacitor. Ch 1: Vout (500mV/div), Ch 2: Vin (20V/div), at zero load current.

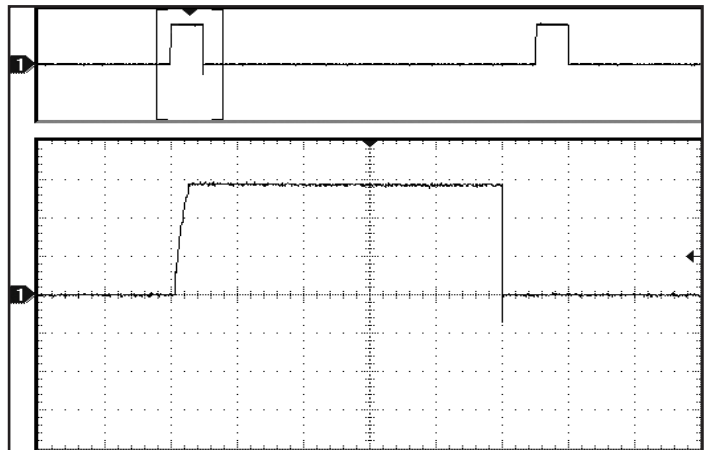

Figure 16: Load current (10A/div) as a function of time when the converter attempts to turn on into a 10 mW short circuit. Bottom trace (10ms/div) is an expansion of the on-time portion of the top trace (100ms/div).

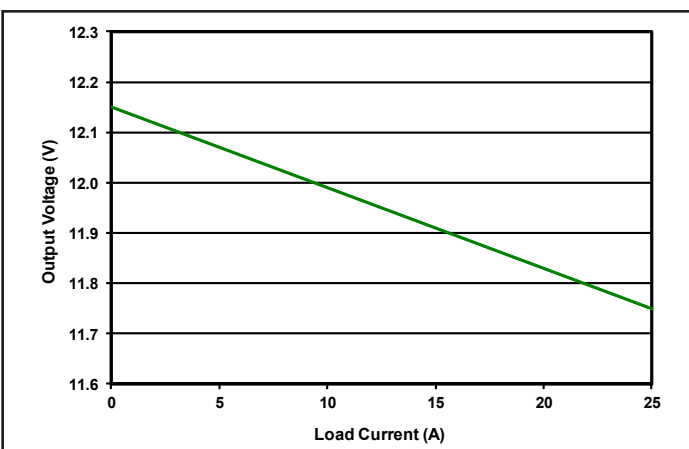

Figure 17: Output voltage vs. load current showing droop characteristic at 25°C.

BASIC OPERATION AND FEATURES

The Exa series converter uses a two-stage power conversion topology. The first stage keeps the output voltage constant over variations in line, load, and temperature. The second stage uses a transformer to provide the functions of input/output isolation and voltage step-down to achieve the low output voltage required.

Both the first stage and the second stage switch at a fixed frequency for predictable EMI performance. Rectification of the transformer's output is accomplished with synchronous rectifiers. These devices, which are MOSFETs with a very low on-state resistance, dissipate significantly less energy than Schottky diodes, enabling the converter to achieve high efficiency.

Dissipation throughout the converter is so low that it does not require a heatsink for operation. Since a heatsink is not required, the converter does not need a metal baseplate or potting material to help conduct the dissipated energy to the heatsink. As an open frame module, the converter can be built more simply and reliably using high yield surface mount techniques on a PCB substrate.

The quarter-brick series converters use the industry standard footprint and pin-out configuration.

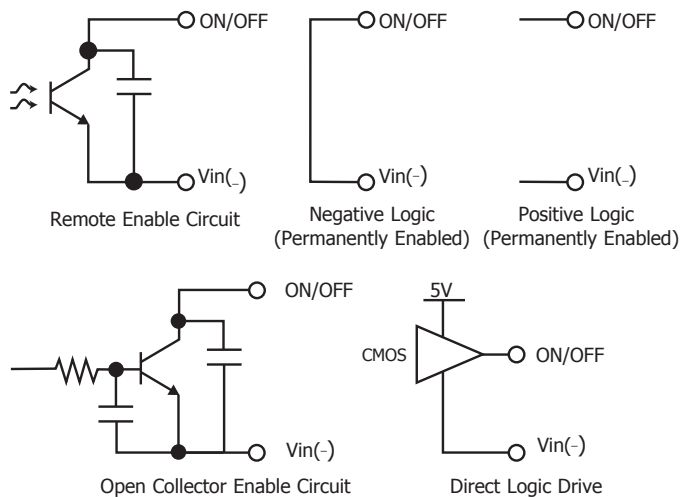

Figure A: Various circuits for driving the ON/OFF pin.

CONTROL FEATURES

REMOTE ON/OFF (Pin 2): The ON/OFF input, Pin 2, permits the user to control when the converter is on or off. This input is referenced to the return terminal of the input bus, Vin(-). The converter is available with either positive or negative logic used for the ON/OFF input.

In the positive logic version, the ON/OFF input is active high (meaning that a high voltage turns the converter on). In the negative logic version, the ON/OFF signal is active low (meaning that a low voltage turns the converter on). Figure A details five possible circuits for driving the ON/OFF pin.

PROTECTION FEATURES

Input Under-Voltage Lockout: The converter is designed to turn off when the input voltage is too low, helping to avoid an input system instability problem, which is described in more detail in the application note titled "Input System Instability" on the SynQor website http://www.synqor.com/documents/appnotes/appnt_System_Instability.pdf. The lockout circuitry is a comparator with DC hysteresis. When the input voltage is rising, it must exceed the typical "Turn-On Voltage Threshold" value* before the converter will turn on. Once the converter is on, the input voltage must fall below the typical Turn-Off Voltage Threshold value before the converter will turn off.

Output Current Limit: If the output current exceeds the "Output DC Current Limit Inception" point*, then a fast linear current limit controller will reduce the output voltage to maintain a constant output current. If as a result, the output voltage falls below the "Output DC Current Limit Shutdown Voltage" value* for more than 50ms, then the unit will enter into hiccup mode, with a 500ms off-time. The unit will then automatically attempt to restart.

Back-Drive Current Limit: If there is negative output current of a magnitude larger than the "Back-Drive Current Limit while Enabled" specification*, then a fast back-drive limit controller will increase the output voltage to maintain a constant output current. If this results in the output voltage exceeding the "Output Over-Voltage Protection" threshold*, then the unit will shut down. The full I-V output characteristics can be seen in Figure 17.

Output Over-Voltage Limit: If the voltage directly across the output pins exceeds the "Output Over-Voltage Protection" threshold*, the converter will immediately stop switching. This shutdown is latching; unlike other shutdown types, the converter will not restart unless the input power is cycled or the ON/OFF input is toggled.

Over-Temperature Shutdown: A temperature sensor on the converter senses the average temperature of the module. The thermal shutdown circuit is designed to turn the converter off when the temperature at the sensed location reaches the "Over-Temperature Shutdown" value*. It will allow the converter to turn on again when the temperature of the sensed location falls by the amount of the "Over-Temperature Shutdown Restart Hysteresis" value*.

APPLICATION CONSIDERATIONS

Droop based current sharing is implemented by only regulating the output of first stage in the two-stage power conversion topology. The inherent impedance of the second stage balances current between multiple modules. This scheme ensures redundancy since there is no active current sharing circuit or common connection to fail. Graphs in this section show two units by way of example, but there is no fundamental limit to the number of units that can be placed in parallel. While the lack of output voltage regulation can seem to be a disadvantage, as we will discuss, it can actually reduce the overall voltage deviation when transient response is considered. Another hidden advantage of droop sharing is a dramatic stability improvement of any external post-regulators.

Droop Damps Downstream Point-of-Loads: It is very common to have additional non-isolated point-of-load converters downstream of an isolated bus converter, called an Intermediate Bus Architecture (IBA). Each of these point-of-load converters requires damping to keep its input system stable. Since the point-of-load converter input current goes up when the bus voltage goes down, it presents an incremental negative resistance. This will be unstable when coupled with a low impedance source, parasitic or explicit inductance, high power, and low bus voltage. The usual solution is to add large amounts of bulk capacitance with inherent or explicit equivalent series resistance to provide damping (See Figure 4 in [Input System Instability application note](#)). The downside of this approach is that the capacitors are expensive and bulky. An alternate solution is to add an explicit series resistance, but this is undesirable because of the additional power loss (See Figure 3 in [Input System Instability application note](#)).

A bus converter with a droop characteristic has an inherent series resistance, without the need for any additional components. Since this resistance comes from the transformer and output rectifiers of the bus converter, it does not represent any additional power loss. The value of this positive damping resistance can be derived directly from the slope of the bus converter output voltage droop characteristic vs. output current. Stability can be determined by evaluating equations 3-6 in the [Input System Instability application note](#).

Voltage Mismatch Impacts Share Accuracy: When multiple units having droop characteristics are placed in parallel, the current sharing accuracy is determined by the output voltage accuracy. A difference in voltage between two units will cause a differential current to flow out of one unit and into the other. Figure B shows an example with two units with output voltage mismatched by 0.5%. In this example, when Unit A is at 100% of its full rated load current, Unit B is only at 90%, effectively reducing the total available current by 5%. SynQor uses factory calibration of each unit to ensure that output voltage is well matched.

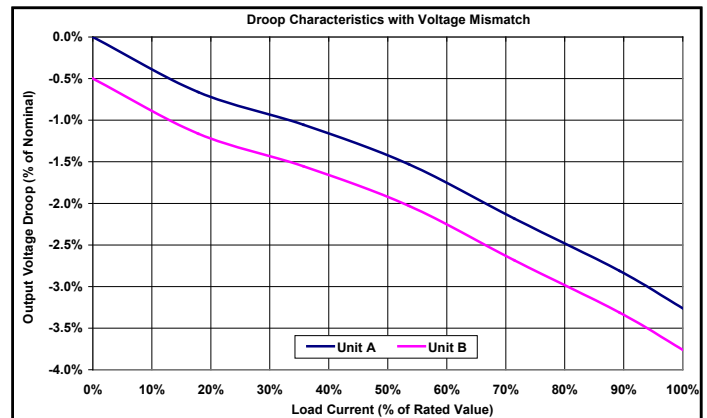

Figure B: Droop Characteristics with Voltage Mismatch

Temperature Mismatch Self Balancing: The slope of the output voltage droop characteristic increases with increased temperature. So, if a paralleled unit were hotter than its neighbor, then it would take more of the load current. However, this situation is self correcting, because as a converter heats up, its droop increases due to an increase in output resistance. As shown in Figure C, this causes the hotter unit to share less current, which in turn cools down and restores equilibrium.

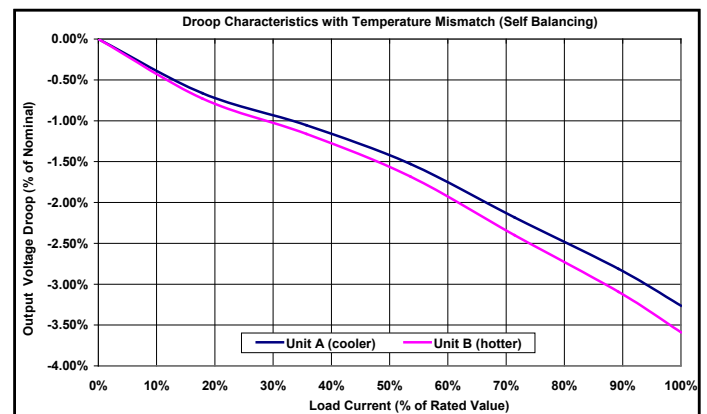

Figure C: Droop Characteristics with Temperature Mismatch (Self Balancing)

Improved Transient Response: While a droop characteristic degrades load regulation, it also improves voltage overshoot in response to a fast removal of load current. This is because the output voltage starts lower when the load is higher. Figure D shows that a droop characteristic can actually reduce the total output voltage deviation caused by variations in load, when the load transient response is taken into account. Note that with zero or low output capacitance, there will be an additional immediate voltage overshoot present on a 100us time scale.

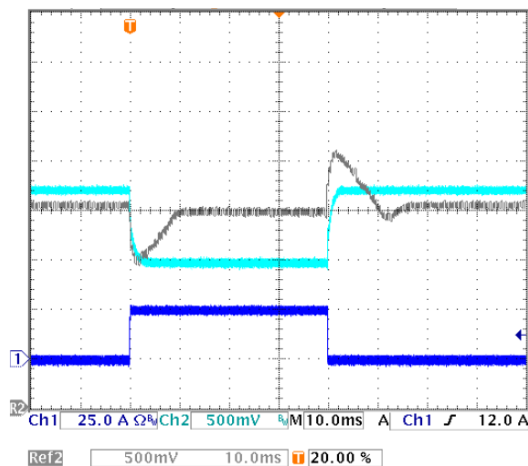

Figure D: Output voltage response to full load step change in output current (Ch2), compared to a fully regulated QEA model (Ref2). 12mF output capacitance.

No output trim or remote sense: Droop share converters do not have remote sense or trim functions, and as such, the corresponding pins are not present. Remote sense and trim would actually interfere with the droop behavior and prevent proper current sharing by maintaining the output voltage of each converter as load current varies. As a result, when placed in parallel, the converter with the highest output voltage would carry the entire load.

In many applications, the output is fed to low-voltage point-of-load converters, which have their own regulating control loops that can easily correct for a range of input voltages.

Output ORing Devices: For system designs requiring redundancy, the converters can be configured either of two ways:

- Directly in parallel
- Paralleled through Or'ing diodes or FETs.

For direct paralleling, the output FETs in the power converter and a few control components are the only non-redundant electronic parts that could be single points of failure. Depending on the required MTBF, this may be a good alternative. On request, SynQor can provide predicted MTBF information on these parts for specific models.

For the highest MTBF, the outputs can be OR'd with series diodes or MOSFETs. With droop sharing in this configuration, there are essentially no single points of failure, since there is no explicit control connection between units, as in an active current sharing solution.

For the best load current sharing accuracy, ORing diodes should be exactly the same type and held to the same temperature as much as possible. Minor differences in the forward drop of these components will affect sharing performance.

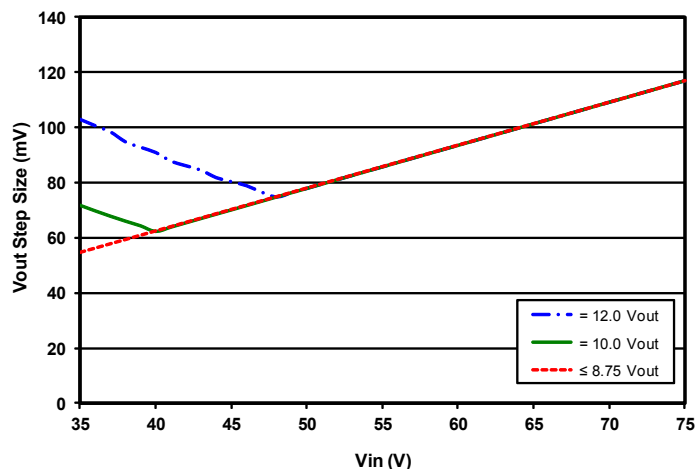

Figure E: Output voltage resolution.

Limited Output Voltage Resolution: The internal voltage control feedback loop has limited resolution. Therefore, the output voltage will exhibit discrete steps as the loop responds to changes in line or load. For instance, on close examination, the startup ramp has a "stair-step" shape. Likewise, a load transient response will be composed of multiple discrete steps. The size of each step is well determined, and is shown in Figure E. A close-up picture of a single step is shown in Figure F. Stepping will not occur under steady state conditions.

* See Electrical Characteristics page.

Input System Instability: This condition can occur because any DC/DC converter appears incrementally as a negative resistance load. A detailed application note titled "Input System Instability" is available on the SynQor website which provides an understanding of why this instability arises, and shows the preferred solution for correcting it.

Application Circuits: Figure G provides a typical circuit diagram which details the input and output filtering.

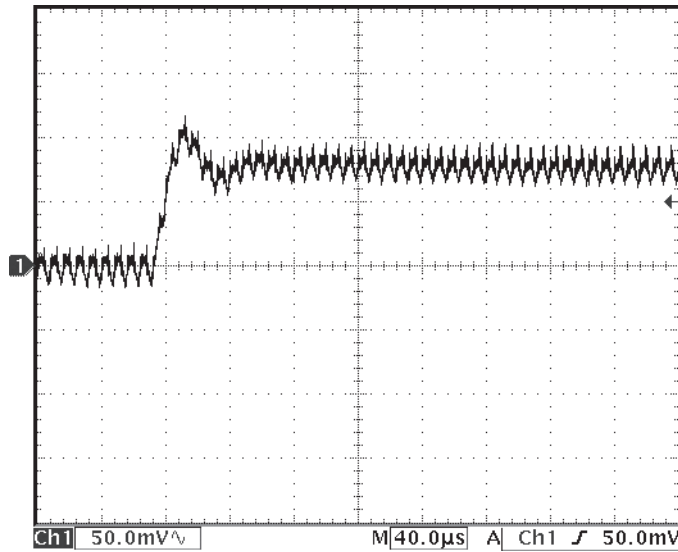

Figure F: Smallest possible Vout step at 48Vin and 12Vout.

Input Filtering and External Input Capacitance: Figure H below shows the internal input filter components. This filter dramatically reduces input terminal ripple current, which otherwise could exceed the rating of an external electrolytic input capacitor. The recommended external input capacitance is specified in the Input Characteristics section on the Electrical Specifications page. More detailed information is available in the application note titled "EMI Characteristics" on the SynQor website http://www.synqor.com/documents/appnotes/appnt_EMI_Characteristics.pdf.

Output Filtering and External Output Capacitance: Figure H below shows the internal output filter components. This filter dramatically reduces output voltage ripple. However, some minimum external output capacitance is required, as specified in the Output Characteristics section on the Electrical Specifications page. No damage will occur without this capacitor connected, but peak output voltage ripple will be much higher.

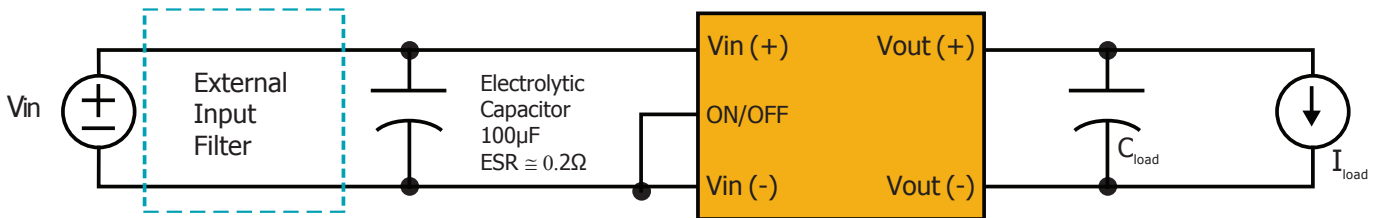

Figure G: Typical application circuit (negative logic unit, permanently enabled).

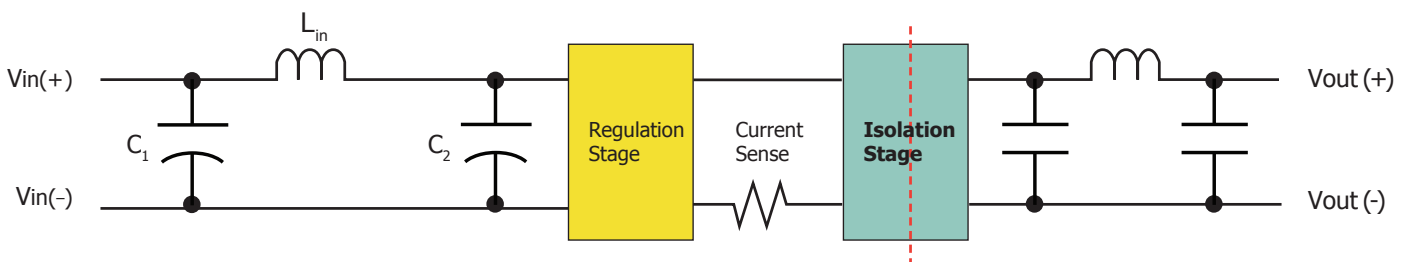

Figure H: Internal Input and Output Filter Diagram (component values listed on specifications page).



Ordering Information

Input: 35-75V
Output: 12V
Current: 25A
Part No.: SQ60120QEx25

Part Numbering System

The part numbering system for SynQor's dc-dc converters follows the format shown in the example below.

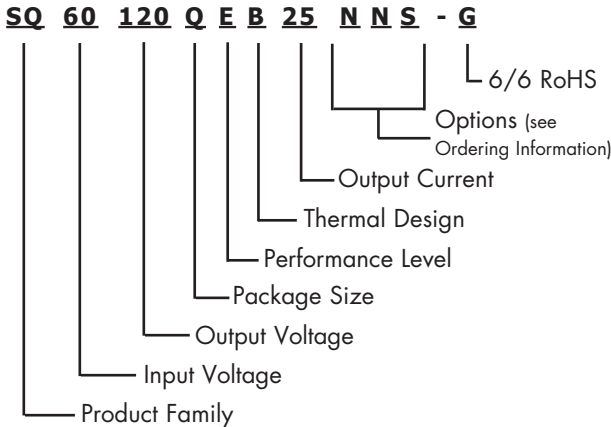

The first 12 characters comprise the base part number and the last 3 characters indicate available options. The "-G" suffix indicates 6/6 RoHS compliance.

Application Notes

A variety of application notes and technical white papers can be downloaded in pdf format from our [website](#).

RoHS Compliance: The EU led RoHS (Restriction of Hazardous Substances) Directive bans the use of Lead, Cadmium, Hexavalent Chromium, Mercury, Polybrominated Biphenyls (PBB), and Polybrominated Diphenyl Ether (PBDE) in Electrical and Electronic Equipment. This SynQor product is 6/6 RoHS compliant. For more information please refer to SynQor's RoHS addendum available at our [RoHS Compliance / Lead Free Initiative web page](#) or e-mail us at rohs@synqor.com.

Contact SynQor for further information and to order:

Phone: **978-849-0600**
 Toll Free: **888-567-9596**
 Fax: **978-849-0602**
 E-mail: **power@synqor.com**
 Web: **www.synqor.com**
 Address: **155 Swanson Road
 Boxborough, MA 01719
 USA**

Ordering Information

The tables below show the valid model numbers and ordering options for converters in this product family. When ordering SynQor converters, please ensure that you use the complete 15 character part number consisting of the 12 character base part number and the additional characters for options. Add "-G" to the model number for 6/6 RoHS compliance.

Model Number	Input Voltage	Output Voltage	Max Output Current
SQ60120QEW25xyz	35-75V	12V	25A

The following options must be included in place of the **wxyz** spaces in the model numbers listed above.

Options Description:			
Thermal Design	Enable Logic	Pin Style	Feature Set
A - Open Frame B - Baseplated	N - Negative P - Positive	K - 0.110" N - 0.145" R - 0.180" Y - 0.250"	S - Standard

Not all combinations make valid part numbers, please contact SynQor for availability.

PATENTS

SynQor holds numerous U.S. patents, one or more of which apply to most of its power converter products. Any that apply to the product(s) listed in this document are identified by markings on the product(s) or on internal components of the product(s) in accordance with U.S. patent laws. SynQor's patents include the following:

5,999,417	6,222,742	6,545,890	6,594,159	6,731,520	6,894,468
6,896,526	6,927,987	7,050,309	7,072,190	7,085,146	7,119,524
7,269,034	7,272,021	7,272,023	7,558,083	7,564,702	7,765,687
7,787,261	8,023,290	8,149,597	8,493,751	8,644,027	9,143,042

Warranty

SynQor offers a three (3) year limited warranty. Complete warranty information is listed on our website or is available upon request from SynQor.