



# Quad Supply and Line Monitor

## FEATURES

- Inputs for Monitoring up to Four Separate Supply Voltage Levels
- Internal Inverter for Sensing a Negative Supply Voltage
- Line/Switch Sense Input for Early Power Source Failure Warning
- Programmable Under- and Over-Voltage Fault Thresholds with Proportional Hysteresis
- A Precision 2.5V Reference
- General Purpose Op-Amp for Auxiliary Use
- Three High Current, >30mA, Open-Collector Outputs Indicate Over-Voltage, Under-Voltage and Power OK Conditions
- Input Supply Under-Voltage Sensing and Start-Latch Eliminate Erroneous Fault Alerts During Start-Up
- 8-40V Supply Operation with 7mA Stand-By Current

## DESCRIPTION

The UC1903 family of quad supply and line monitor integrated circuits will respond to under- and over-voltage conditions on up to four continuously monitored voltage levels. An internal op-amp inverter allows at least one of these levels to be negative. A separate line/switcher sense input is available to provide early warning of line or other power source failures.

The fault window adjustment circuit on these devices provides easy programming of under- and over-voltage thresholds. The thresholds, centered around a precision 2.5V reference, have an input hysteresis that scales with the window width for precise, glitch-free operation. A reference output pin allows the sense input fault windows to be scaled independently using simple resistive dividers.

The three open collector outputs on these devices will sink in excess of 30mA of load current when active. The under- and over-voltage outputs respond after separate, user defined, delays to respective fault conditions. The third output is active during any fault condition including under- and over-voltage, line/switcher faults, and input supply under-voltage. The off state of this output indicates a "power OK" situation.

An additional, uncommitted, general purpose op-amp is also included. This op-amp, capable of sourcing 20mA of output current, can be used for a number of auxiliary functions including the sensing and amplification of a feedback error signal when the 2.5V output is used as a system reference.

In addition, these ICs are equipped with a start-latch to prevent erroneous under-voltage indications during start-up. These parts operate over an 8V to 40V input supply range and require a typical stand-by current of only 7mA.

## BLOCK DIAGRAM

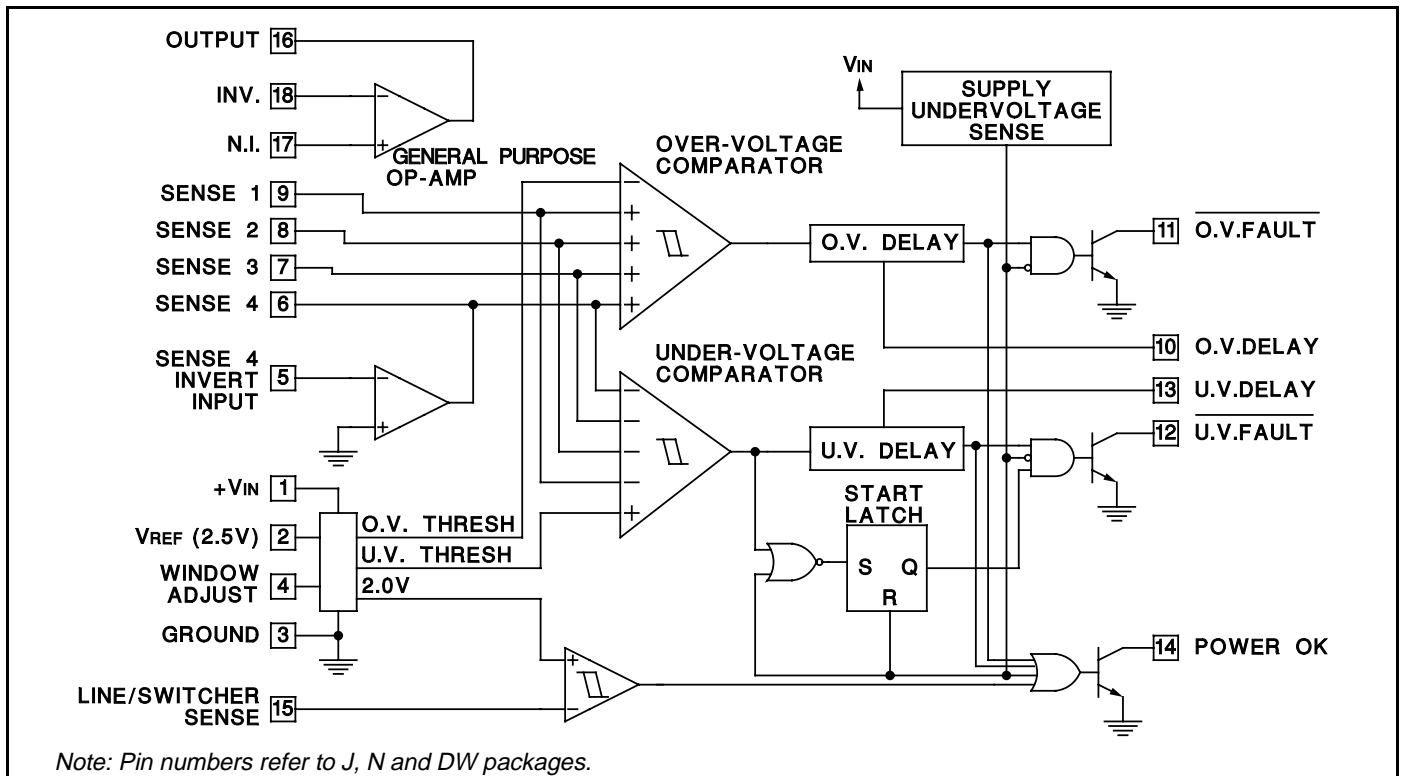

### ABSOLUTE MAXIMUM RATINGS (Note 1)

Supply Voltage (+VIN) . . . . .	+40V
Open Collector Output Voltages . . . . .	+40V
Open Collector Output Currents . . . . .	50mA
Sense 1-4 Input Voltages . . . . .	-0.3V to +20V
Line/Switcher Sense Input Voltage . . . . .	-0.3V to +40V
Op-Amp and Inverter Input Voltages . . . . .	-0.3V to +40V
Op-Amp and Inverter Output Currents . . . . .	-40mA
Window Adjust Voltage . . . . .	0.0V to +10V
Delay Pin Voltages . . . . .	0.0V to +5V
Reference Output Current . . . . .	-40mA
Power Dissipation at TA = 25°C (Note 1) . . . . .	1000mW
Power Dissipation at Tc = 25°C (Note 1) . . . . .	2000mW
Operating Junction Temperature . . . . .	-55°C to +150°C
Storage Temperature . . . . .	-65°C to +150°C
Lead Temperature (Soldering, 10 Seconds) . . . . .	300°C

Note 1: Voltages are referenced to ground (Pin 3). Currents are positive into, negative out of, the specified terminals. Consult Packaging Section of Databook for thermal limitations and considerations of package.

### CONNECTION DIAGRAMS

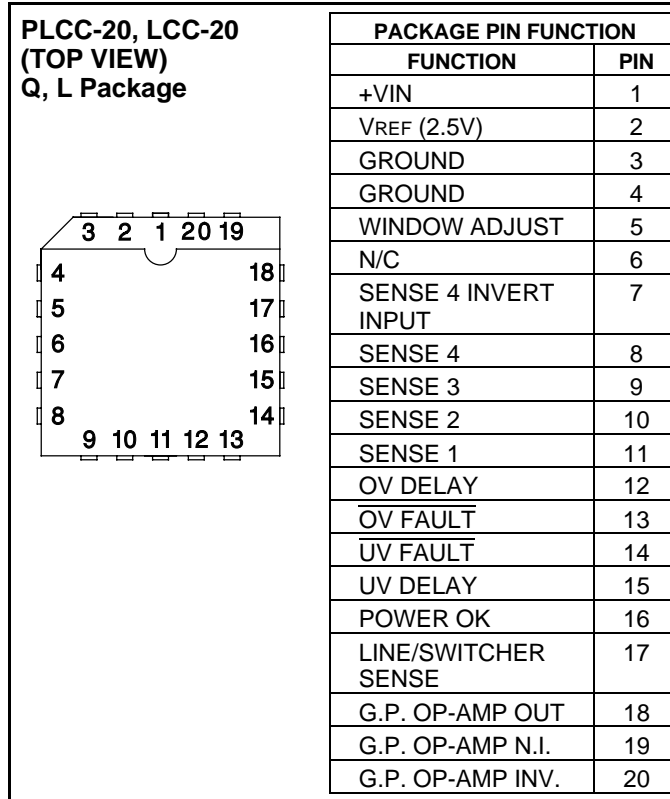
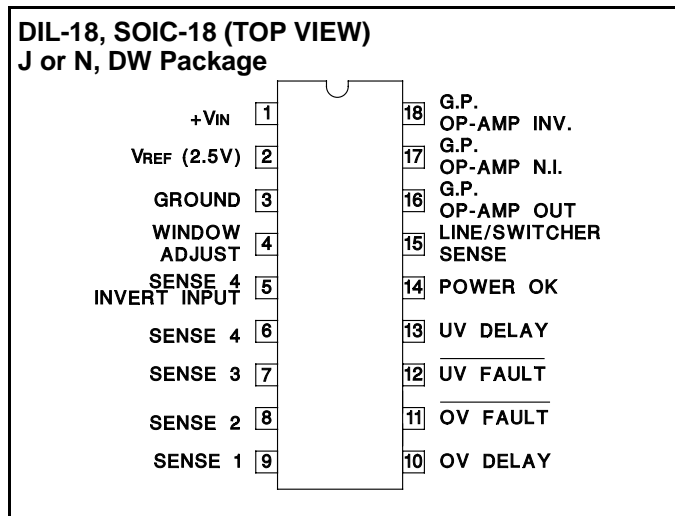

**ELECTRICAL CHARACTERISTICS:** Unless otherwise stated, these specifications apply for TA = -55°C to +125°C for the UC1903; -40°C to +85°C for the UC2903; and 0°C to +70°C for the UC3903; +VIN = 15V; Sense Inputs (Pins 6-9 and Pin 15) = 2.5V; VPIN 4 = 1.0V, TA = TJ.

PARAMETERS	TEST CONDITIONS	UC1903 / UC2903			UC3903			UNITS
		MIN	TYP	MAX	MIN	TYP	MAX	
<b>Supply</b>								
Input Supply Current	No Faults		7	9		7	11	mA
	UV, OV and Line Fault		10	15		10	18	mA
Supply Under Voltage Threshold (VSUV)	Fault Outputs Enabled	6.0	7.0	7.5	5.5	7.0	8.0	V
Minimum Supply to Enable Power OK Output			3.0	4.0		3.0	4.0	V
<b>Reference</b>								
Output Voltage (VREF)	TJ = 25°C	2.485	2.5	2.515	2.470	2.5	2.530	V
	Over Temperature	2.465		2.535	2.465		2.535	V
Load Regulation	IL = 0 to 10mA		1	10		1	15	mV
Line Regulation	+VIN = 8 to 40V		1	4		1	8	mV
Short Circuit Current	TJ = 25°C		40			40		mA
<b>Fault Thresholds (Note 4)</b>								
OV Threshold Adj.	Offset from VREF as a function of VPIN 4 Input = Low to High, 0.5V ≤ VPIN 4 ≤ 2.5V	.230	.25	.270	.230	.25	.270	V/V
UV Threshold Adj.	Offset from VREF as a function of VPIN 4 Input = High to Low, 0.5V ≤ VPIN 4 ≤ 2.5V	-.270	-.25	-.230	-.270	-.25	-.230	V/V

**ELECTRICAL CHARACTERISTICS:** Unless otherwise stated, these specifications apply for  $T_A = -55^\circ\text{C}$  to  $+125^\circ\text{C}$  for the UC1903;  $-40^\circ\text{C}$  to  $+85^\circ\text{C}$  for the UC2903; and  $0^\circ\text{C}$  to  $+70^\circ\text{C}$  for the UC3903;  $+V_{IN} = 15\text{V}$ ; Sense Inputs (Pins 6–9 and Pin 15) =  $2.5\text{V}$ ;  $V_{PIN\ 4} = 1.0\text{V}$ ,  $T_A = T_J$ .

PARAMETERS	TEST CONDITIONS	UC1903/UC2903			UC3903			UNITS
		MIN	TYP	MAX	MIN	TYP	MAX	
<b>Fault Thresholds (cont.)</b>								
OV & UV Threshold Hyst.	$0.5\text{V} \leq V_{PIN\ 4} \leq 2.5\text{V}$	10	20	30	10	20	30	mV/V
OV & UV Threshold Supply Sensitivity	$+V_{IN} = 8\text{V}$ to $40\text{V}$		.002	.01		.002	.02	%/V
Adjust Pin (Pin 4) Input Bias Current	$0.5\text{V} \leq V_{PIN\ 4} \leq 2.5\text{V}$		$\pm 1$	$\pm 10$		$\pm 1$	$\pm 12$	$\mu\text{A}/\text{V}$
Line Sense Threshold	Input = High to Low	1.94	2.0	2.06	1.9	2.0	2.1	V
Line Sense Threshold Hyst.		125	175	225	100	175	250	mV
<b>Sense Inputs</b>								
Sense 1-4 Input Bias Current	Input = $2.8\text{V}$ (Note 2)		1	3		1	6	$\mu\text{A}$
	Input = $2.2$ (Note 2)		-1	-3		-1	-6	$\mu\text{A}$
Line Sense Input Bias Current	Input = $2.3\text{V}$ (Note 2)		1	3		1	6	$\mu\text{A}$
<b>OV and UV Fault Delay</b>								
Charging Current			60			60		$\mu\text{A}$
Threshold Voltage	Delay Pin = Low to High		1.8			1.8		V
Threshold Hysteresis	$T_J = 25^\circ\text{C}$		250			250		mV
Delay	Ratio of Threshold Voltage to Charging Current	20	30	50	20	30	50	ms/ $\mu\text{F}$
<b>Fault Outputs (<math>\overline{\text{OV}}</math>, <math>\overline{\text{UV}}</math>, &amp; Power OK)</b>								
Maximum Current	$V_{OUT} = 2\text{V}$	30	70		30	70		mA
Saturation Voltage	$I_{OUT} = 12\text{mA}$		.25	.40		.25	.40	V
Leakage Current	$V_{OUT} = 40\text{V}$		3	25		3	25	$\mu\text{A}$
<b>Sense 4 Inverter (Note 3)</b>								
Input Offset Voltage			2	8		2	10	mV
Input Bias Current			.1	2		.1	4	$\mu\text{A}$
Open Loop Gain		65	80		65	80		dB
PSRR	$+V_{IN} = 8$ to $40\text{V}$	65	100		65	100		dB
Unity Gain Frequency			1			1		MHz
Slew Rate			.4			.4		V/ $\mu\text{s}$
Short Circuit Current	$T_J = 25^\circ\text{C}$		40			40		mA
<b>G.P. Op-Amp (Note 3)</b>								
Input Offset Voltage			1	5		1	8	mV
Input Bias Voltage			.1	2		.1	4	$\mu\text{A}$
Input Offset Current			.01	.5		.01	1.0	$\mu\text{A}$
Open Loop Gain		65	120		65	120		dB
CMRR	$V_{CM} = 0$ to $+V_{IN} = 2.0\text{V}$	65	100		65	100		dB
PSRR	$+V_{IN} = 8$ to $40\text{V}$	65	100		65	100		dB
Unity Gain Frequency			1			1		MHz
Slew Rate			.4			.4		V/ $\mu\text{s}$
Short Circuit Current	$T_J = 25^\circ\text{C}$		40			40		mA

Note 2: These currents represent maximum input bias currents required as the sense inputs cross appropriate thresholds.

Note 3: When either the G.P. OP-Amp, or the Sense 4 Inverter, are configured for sensing a negative supply voltage, the divider resistance at the inverting input should be chosen such that the nominal divider current is  $\leq 1.4\text{mA}$ . With the divider current at or below this level possible latching of the circuit is avoided. Proper operation for currents at or below  $1.4\text{mA}$  is 100% tested in production.

Note 4: Reference to pin numbers in this specification pertain to 18 pin DIL N and J packages and 18 pin SOIC DW package.

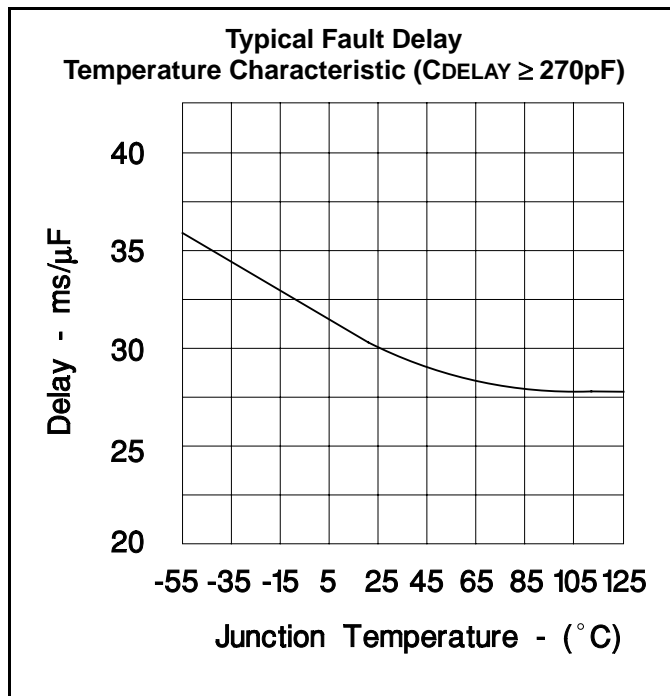
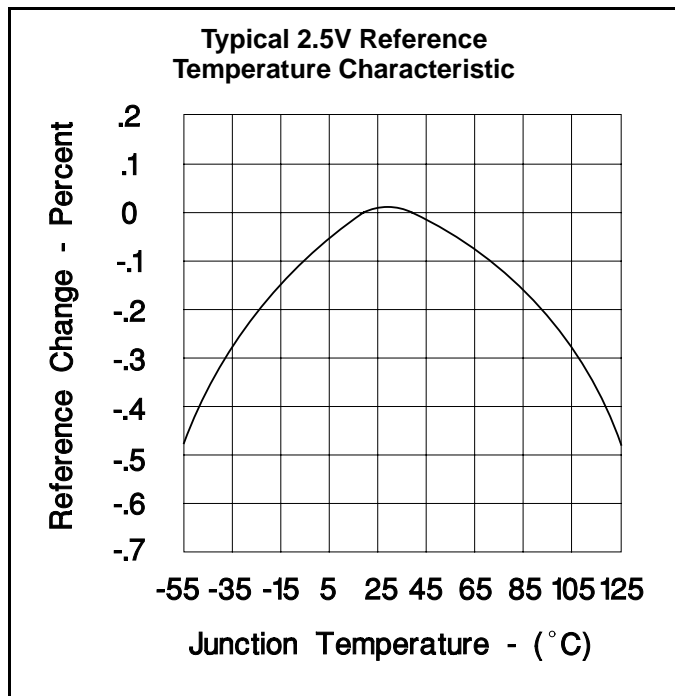

**OPERATION AND APPLICATION INFORMATION**

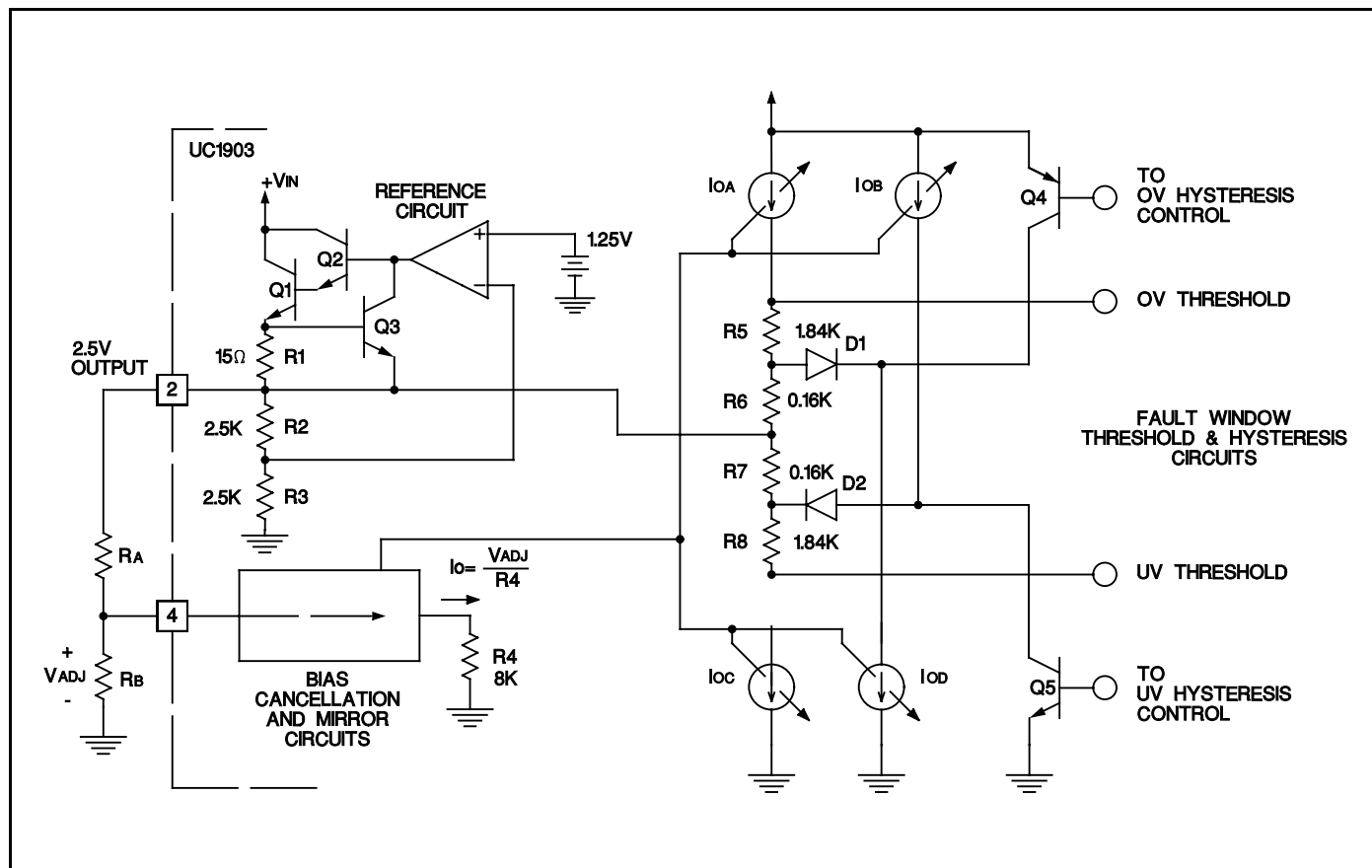

**Figure 1.** The UC1903 fault window circuitry generates OV and UV thresholds centered around the 2.5V reference. Window magnitude and threshold hysteresis are proportional to the window adjust input voltage at Pin 4.

## OPERATION AND APPLICATION INFORMATION

### Setting a Fault Window

The fault thresholds on the UC1903 are generated by creating positive and negative offsets, equal in magnitude, that are referenced to the chip's 2.5V reference. The resulting fault window is centered around 2.5V and has a magnitude equal to that of the applied offsets. Simplified schematics of the fault window and reference circuits are shown in Figure 1 (see previous page). The magnitude of the offsets is determined by the voltage applied at the window adjust pin, Pin 4. A bias cancellation circuit keeps the input current required at Pin 4 low, allowing the use of a simple resistive divider off the reference to set the adjust pin voltage.

The adjust voltage at Pin 4 is internally applied across R4, and an 8k resistor. The resulting current is mirrored four times to generate current sources IOA, IOB, IOC, and IOD, all equal in magnitude. When all four of the sense inputs are inside the fault window, a no-fault condition, Q4 and Q5 are turned on. In combination with D1 and D2 this prevents IOB and IOD from affecting the fault thresholds. In this case, the OV and UV thresholds are equal to  $V_{REF} + IOA(R5 + R6)$  and  $V_{REF} - IOC(R7 + R8)$  respectively. The fault window can be expressed as:

$$(1) \quad 2.5V \pm \frac{V_{ADJ}}{4}$$

In terms of a sensed nominal voltage level,  $V_S$ , the window as a percent variation is:

$$(2) \quad V_S \pm (10 \cdot V_{ADJ}) \%$$

When a sense input moves outside the fault window given in equation(1), the appropriate hysteresis control signal turns off Q4 or Q5. For the under-voltage case, Q5 is disabled and current source IOB flows through D2. The net current through R7 becomes zero as IOB cancels IOC, giving an 8% reduction in the UV threshold offset. The over-voltage case is the same, with Q4 turning off, allowing IOD to cancel the current flow, IOA, through R6. The result is a

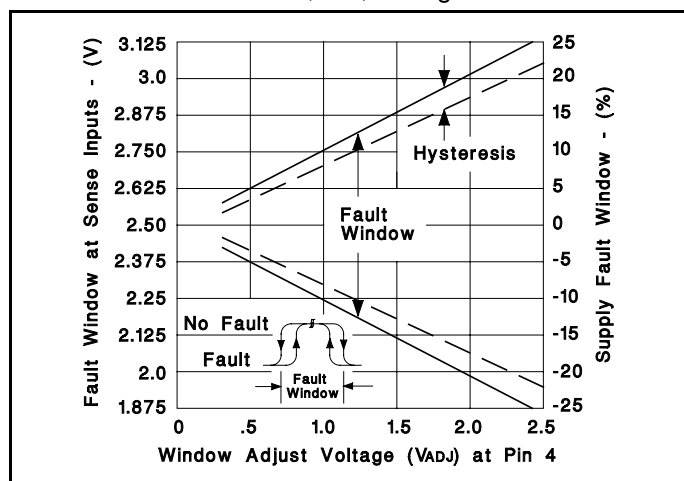
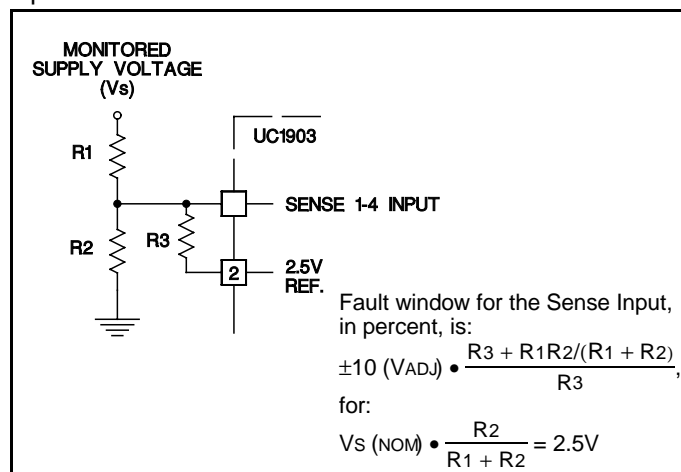

**Figure 2.** The fault window and threshold hysteresis scale as a function of the voltage applied at Pin 4, the window adjust pin.

hysteresis at the sense inputs which is always 8% of the window magnitude. This is shown graphically in Figure 2.

### Fault Windows Can Be Scaled Independently

In many applications, it may be desirable to monitor various supply voltages, or voltage levels, with varying fault windows. Using the reference output and external resistive dividers this is easily accomplished with the UC1903. Figures 3 and 4 illustrate how the fault window at any sense input can be scaled independently of the remaining inputs.



**Figure 3.** Using the reference output and a resistive divider, a sense input with an independently wider fault window can be generated.

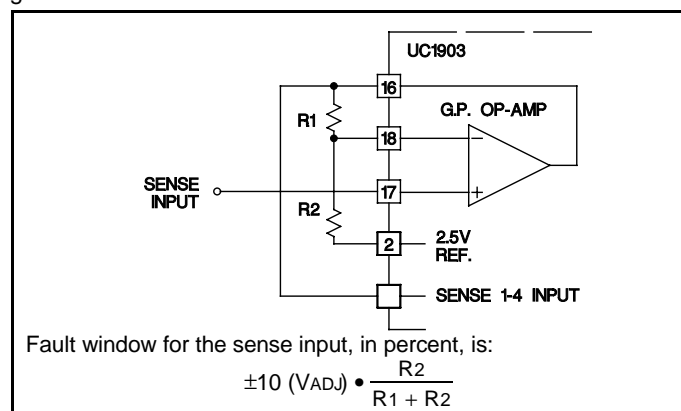

**Figure 4.** The general purpose op-amp on the UC1903 can be used to create a sense input with an independently tighter fault window.

Figure 4 demonstrates one of many auxiliary functions that the uncommitted op-amp on the UC1903 can be used for. Alternatively, this op-amp can be used to buffer high impedance points, perform logic functions, or for sensing and amplification. For example, the G.P. op-amp, combined with the 2.5V reference, can be used to produce and buffer an optically coupled feedback signal in isolated supplies with primary side control. The output stage of this op-amp is detailed in Figure 5. The NPN emitter follower provides high source current capability.  $\geq 20mA$  while the substrate device, Q3, provides good transient sinking capability.

OPERATION AND APPLICATION INFORMATION (continued)

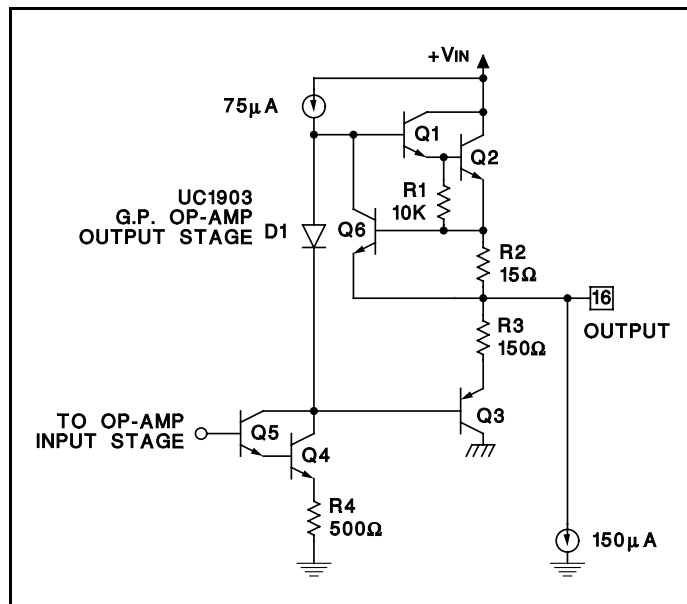

**Figure 5.** The G.P. op-amp on the UC1903 has a high source current ( $\geq 20\text{mA}$ ) capability and enhanced transient sinking capability through substrate device Q3.

**Sensing a Negative Voltage Level**

The UC1903 has a dedicated inverter coupled to the sense 4 input. With this inverter, a negative voltage level can be sensed as shown in Figure 6. The output of the inverter is an unbiased emitter follower. By tying the inverting input, Pin 5, high the output emitter follower will be reverse biased, leaving the sense 4 input in a high impedance state. In this manner, the sense 4 input can be used, as the remaining sense inputs would be, for sensing positive voltage levels.

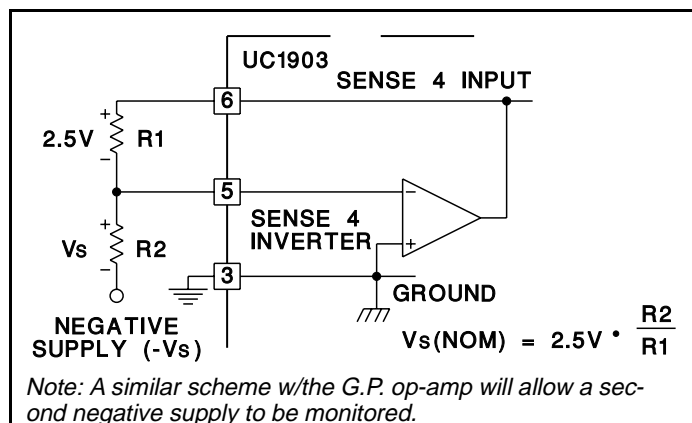
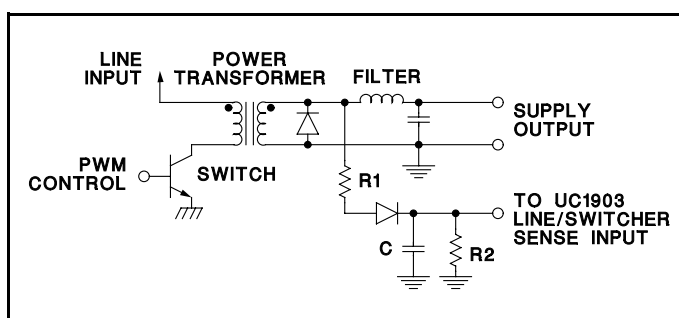

**Figure 6.** Inverting the sense 4 input for monitoring a negative supply is accommodated with the dedicated inverter.

**Using The Line/Switcher Sense Output**

The line switcher sense input to the UC1903 can be used for early detection of line, switcher, or other power source, failures. Internally referenced to 2.0V, the line sense comparator will cause the POWER OK output to indicate a fault (active low) condition when the LINE/SWITCHER

SENSE input goes from above to below 2.0V. The line sense comparator has approximately 175mV of hysteresis requiring the line/switcher input to reach 2.175V before the POWER OK output device can be turned off, allowing a no-fault indication. In Figure 7 an example showing the use of the LINE/SWITCHER SENSE input for early switcher-fault detection is detailed. A sample signal is taken from the output of the power transformer, rectified and filtered, and used at the line/switcher input. By adjusting the R2C time constant with respect to the switching frequency of the supply and the hold up time of the output capacitor, switcher faults can be detected before supply outputs are significantly affected.



**Figure 7.** The line/switcher sense input can be used for an early line or switcher fault indication.

**OV and UV Comparators Maintain Accurate Thresholds**

The structure of the  $\overline{\text{OV}}$  and  $\overline{\text{UV}}$  comparators, shown in Figure 8 results in accurate fault thresholds even in the case where multiple sense inputs cross a fault threshold simultaneously. Unused sense inputs can be tied either to the 2.5V reference, or to another, utilized, sense input. The four under- and over-voltage sense inputs on the UC1903 are clamped as detailed on the Sense 1 input in Figure 8. The series 2k resistor, R1, and zener diode Z1, prevent extreme under- and over-voltage conditions from inverting the outputs of the fault comparators. A parasitic diode, D1, is present at the inputs as well. Under normal operation it is advisable to insure that voltage levels at all of the sense inputs stay above -0.3V. The same type of input protection exists at the line sense input, Pin 15, except a 5k series resistor is used.

The fault delay circuitry on the UC1903 is also shown in Figure 8. In the case of an over-voltage condition at one of the sense inputs Q20 is turned off, allowing the internal 60µA current source to charge the user-selected delay capacitor. When the capacitor voltage reaches 1.8V, the OV and POWER OK outputs become active low. When the fault condition goes away Q20 is turned back on, rapidly discharging the delay capacitor. Operation of the under-voltage delay is, with appropriate substitutions, the same.

OPERATION AND APPLICATION INFORMATION (continued)

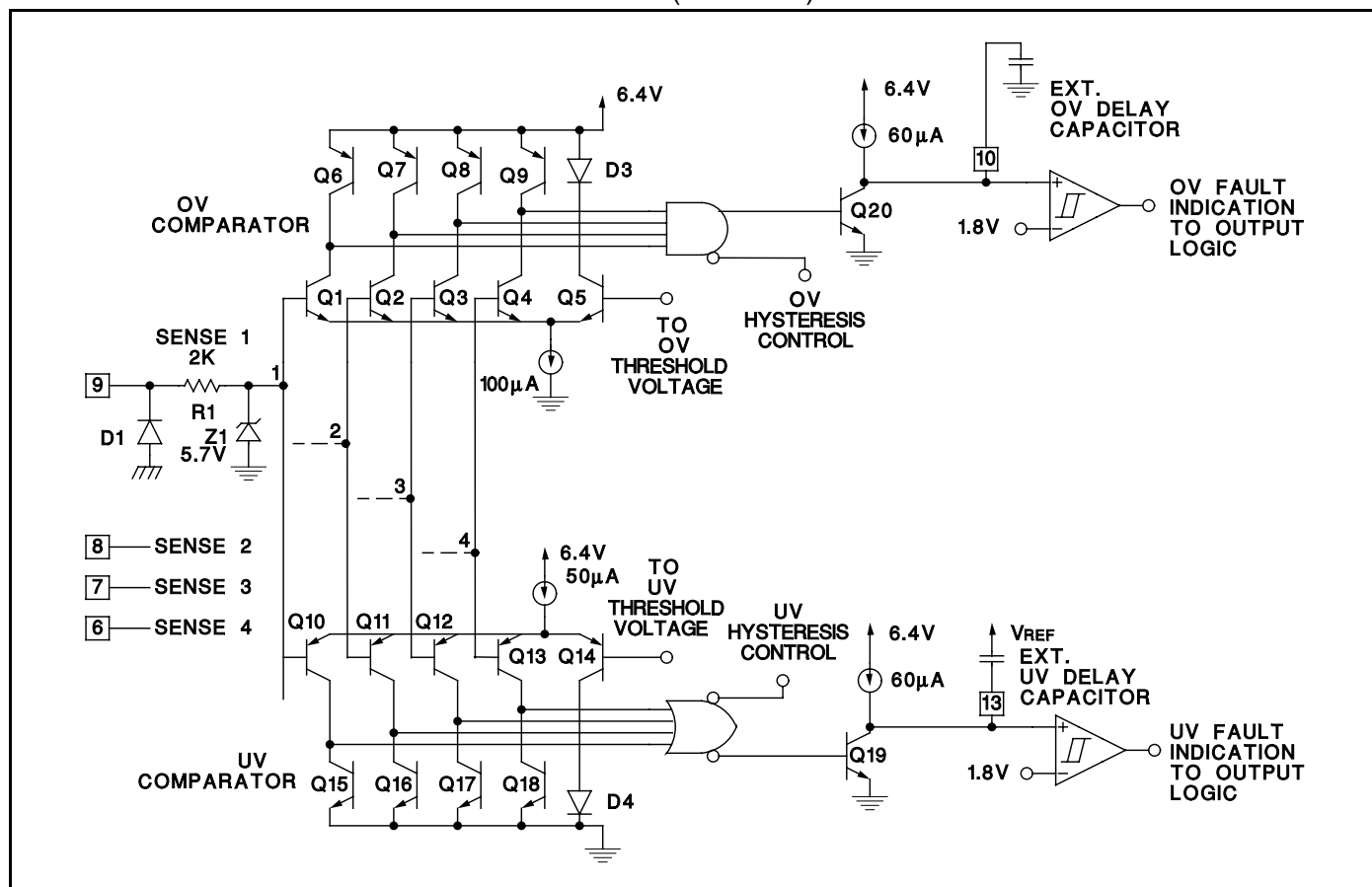

**Figure 8.** The OV and UV comparators on the UC1903 trigger respective fault delay circuits when one or more of the sense inputs move outside the fault window. Input clamps insure proper operation under extreme fault conditions. Terminating the UV delay capacitor to VREF assures correct logic at power up.

**Start Latch and Supply Under-Voltage Sense Allow Predictable Power-Up**

The supply under-voltage sense and start-latch circuitry on the UC1903 prevents fault indications during start-up or low input supply (+VIN) conditions. When the input supply voltage is below the supply under-voltage threshold the OV and UV fault outputs are disabled and the POWER OK output is active low. The POWER OK output will remain active until the input supply drops below approximately 3.0V. With +VIN below this level, all of the open collector outputs will be off.

When the input supply is low, the under-voltage sense circuitry resets the start-latch. With the start-latch reset, the UV fault output will remain disabled until the input supply rises to its normal operating level (8-40V), and all of the sense inputs are above the under-voltage threshold. This allows slow starting, or supply sequencing, without an artificial under-voltage fault indication. Once the latch is set, the UV fault output will respond if any of the sense inputs drop below the under-voltage threshold.

In no event shall TI's liability arising out of such information exceed the total purchase price of the TI part(s) at issue in this document sold by TI to Customer on an annual basis.

**PACKAGING INFORMATION**

Orderable Device	Status <sup>(1)</sup>	Package Type	Package Drawing	Pins	Package Qty	Eco Plan <sup>(2)</sup>	Lead/Ball Finish	MSL Peak Temp <sup>(3)</sup>
5962-88697012A	ACTIVE	LCCC	FK	20	1	TBD	POST-PLATE	N / A for Pkg Type
5962-8869701VA	ACTIVE	CDIP	J	18	1	TBD	A42 SNPB	N / A for Pkg Type
UC1903J	ACTIVE	CDIP	J	18	1	TBD	A42 SNPB	N / A for Pkg Type
UC1903J883B	ACTIVE	CDIP	J	18	1	TBD	A42 SNPB	N / A for Pkg Type
UC1903L	ACTIVE	LCCC	FK	20	1	TBD	POST-PLATE	N / A for Pkg Type
UC1903L883B	ACTIVE	LCCC	FK	20	1	TBD	POST-PLATE	N / A for Pkg Type
UC2903DW	ACTIVE	SOIC	DW	18	40	Green (RoHS & no Sb/Br)	CU NIPDAU	Level-2-260C-1 YEAR
UC2903DWG4	ACTIVE	SOIC	DW	18	40	Green (RoHS & no Sb/Br)	CU NIPDAU	Level-2-260C-1 YEAR
UC2903DWTR	ACTIVE	SOIC	DW	18	2000	Green (RoHS & no Sb/Br)	CU NIPDAU	Level-2-260C-1 YEAR
UC2903DWTRG4	ACTIVE	SOIC	DW	18	2000	Green (RoHS & no Sb/Br)	CU NIPDAU	Level-2-260C-1 YEAR
UC2903J	ACTIVE	CDIP	J	18	1	TBD	A42 SNPB	N / A for Pkg Type
UC2903N	ACTIVE	PDIP	N	18	20	Green (RoHS & no Sb/Br)	CU NIPDAU	N / A for Pkg Type
UC2903NG4	ACTIVE	PDIP	N	18	20	Green (RoHS & no Sb/Br)	CU NIPDAU	N / A for Pkg Type
UC2903Q	ACTIVE	PLCC	FN	20	46	Green (RoHS & no Sb/Br)	CU SN	Level-2-260C-1 YEAR
UC2903QG3	ACTIVE	PLCC	FN	20	46	Green (RoHS & no Sb/Br)	CU SN	Level-2-260C-1 YEAR
UC2903QTR	ACTIVE	PLCC	FN	20	1000	Green (RoHS & no Sb/Br)	CU SN	Level-2-260C-1 YEAR
UC2903QTRG3	ACTIVE	PLCC	FN	20	1000	Green (RoHS & no Sb/Br)	CU SN	Level-2-260C-1 YEAR
UC3903DW	ACTIVE	SOIC	DW	18	40	Green (RoHS & no Sb/Br)	CU NIPDAU	Level-2-260C-1 YEAR
UC3903DWG4	ACTIVE	SOIC	DW	18	40	Green (RoHS & no Sb/Br)	CU NIPDAU	Level-2-260C-1 YEAR
UC3903DWTR	ACTIVE	SOIC	DW	18	2000	Green (RoHS & no Sb/Br)	CU NIPDAU	Level-2-260C-1 YEAR
UC3903DWTRG4	ACTIVE	SOIC	DW	18	2000	Green (RoHS & no Sb/Br)	CU NIPDAU	Level-2-260C-1 YEAR
UC3903J	ACTIVE	CDIP	J	18	1	TBD	A42 SNPB	N / A for Pkg Type
UC3903N	ACTIVE	PDIP	N	18	20	Green (RoHS & no Sb/Br)	CU NIPDAU	N / A for Pkg Type
UC3903NG4	ACTIVE	PDIP	N	18	20	Green (RoHS & no Sb/Br)	CU NIPDAU	N / A for Pkg Type
UC3903Q	ACTIVE	PLCC	FN	20	46	Green (RoHS & no Sb/Br)	CU SN	Level-2-260C-1 YEAR
UC3903QG3	ACTIVE	PLCC	FN	20	46	Green (RoHS & no Sb/Br)	CU SN	Level-2-260C-1 YEAR
UC3903QTRG3	ACTIVE	PLCC	FN	20		TBD	Call TI	Call TI

<sup>(1)</sup> The marketing status values are defined as follows:  
**ACTIVE:** Product device recommended for new designs.

---

**LIFEBUY:** TI has announced that the device will be discontinued, and a lifetime-buy period is in effect.

**NRND:** Not recommended for new designs. Device is in production to support existing customers, but TI does not recommend using this part in a new design.

**PREVIEW:** Device has been announced but is not in production. Samples may or may not be available.

**OBSOLETE:** TI has discontinued the production of the device.

<sup>(2)</sup> Eco Plan - The planned eco-friendly classification: Pb-Free (RoHS), Pb-Free (RoHS Exempt), or Green (RoHS & no Sb/Br) - please check <http://www.ti.com/productcontent> for the latest availability information and additional product content details.

**TBD:** The Pb-Free/Green conversion plan has not been defined.

**Pb-Free (RoHS):** TI's terms "Lead-Free" or "Pb-Free" mean semiconductor products that are compatible with the current RoHS requirements for all 6 substances, including the requirement that lead not exceed 0.1% by weight in homogeneous materials. Where designed to be soldered at high temperatures, TI Pb-Free products are suitable for use in specified lead-free processes.

**Pb-Free (RoHS Exempt):** This component has a RoHS exemption for either 1) lead-based flip-chip solder bumps used between the die and package, or 2) lead-based die adhesive used between the die and leadframe. The component is otherwise considered Pb-Free (RoHS compatible) as defined above.

**Green (RoHS & no Sb/Br):** TI defines "Green" to mean Pb-Free (RoHS compatible), and free of Bromine (Br) and Antimony (Sb) based flame retardants (Br or Sb do not exceed 0.1% by weight in homogeneous material)

<sup>(3)</sup> MSL, Peak Temp. -- The Moisture Sensitivity Level rating according to the JEDEC industry standard classifications, and peak solder temperature.

**Important Information and Disclaimer:**The information provided on this page represents TI's knowledge and belief as of the date that it is provided. TI bases its knowledge and belief on information provided by third parties, and makes no representation or warranty as to the accuracy of such information. Efforts are underway to better integrate information from third parties. TI has taken and continues to take reasonable steps to provide representative and accurate information but may not have conducted destructive testing or chemical analysis on incoming materials and chemicals. TI and TI suppliers consider certain information to be proprietary, and thus CAS numbers and other limited information may not be available for release.

In no event shall TI's liability arising out of such information exceed the total purchase price of the TI part(s) at issue in this document sold by TI to Customer on an annual basis.

**TAPE AND REEL INFORMATION**



**QUADRANT ASSIGNMENTS FOR PIN 1 ORIENTATION IN TAPE**



\*All dimensions are nominal

Device	Package Type	Package Drawing	Pins	SPQ	Reel Diameter (mm)	Reel Width W1 (mm)	A0 (mm)	B0 (mm)	K0 (mm)	P1 (mm)	W (mm)	Pin1 Quadrant
UC2903DWTR	SOIC	DW	18	2000	330.0	24.4	10.9	12.0	2.7	12.0	24.0	Q1
UC3903DWTR	SOIC	DW	18	2000	330.0	24.4	10.9	12.0	2.7	12.0	24.0	Q1

**TAPE AND REEL BOX DIMENSIONS**



\*All dimensions are nominal

Device	Package Type	Package Drawing	Pins	SPQ	Length (mm)	Width (mm)	Height (mm)
UC2903DWTR	SOIC	DW	18	2000	346.0	346.0	41.0
UC3903DWTR	SOIC	DW	18	2000	346.0	346.0	41.0

## IMPORTANT NOTICE

Texas Instruments Incorporated and its subsidiaries (TI) reserve the right to make corrections, modifications, enhancements, improvements, and other changes to its products and services at any time and to discontinue any product or service without notice. Customers should obtain the latest relevant information before placing orders and should verify that such information is current and complete. All products are sold subject to TI's terms and conditions of sale supplied at the time of order acknowledgment.

TI warrants performance of its hardware products to the specifications applicable at the time of sale in accordance with TI's standard warranty. Testing and other quality control techniques are used to the extent TI deems necessary to support this warranty. Except where mandated by government requirements, testing of all parameters of each product is not necessarily performed.

TI assumes no liability for applications assistance or customer product design. Customers are responsible for their products and applications using TI components. To minimize the risks associated with customer products and applications, customers should provide adequate design and operating safeguards.

TI does not warrant or represent that any license, either express or implied, is granted under any TI patent right, copyright, mask work right, or other TI intellectual property right relating to any combination, machine, or process in which TI products or services are used. Information published by TI regarding third-party products or services does not constitute a license from TI to use such products or services or a warranty or endorsement thereof. Use of such information may require a license from a third party under the patents or other intellectual property of the third party, or a license from TI under the patents or other intellectual property of TI.

Reproduction of TI information in TI data books or data sheets is permissible only if reproduction is without alteration and is accompanied by all associated warranties, conditions, limitations, and notices. Reproduction of this information with alteration is an unfair and deceptive business practice. TI is not responsible or liable for such altered documentation. Information of third parties may be subject to additional restrictions.

Resale of TI products or services with statements different from or beyond the parameters stated by TI for that product or service voids all express and any implied warranties for the associated TI product or service and is an unfair and deceptive business practice. TI is not responsible or liable for any such statements.

TI products are not authorized for use in safety-critical applications (such as life support) where a failure of the TI product would reasonably be expected to cause severe personal injury or death, unless officers of the parties have executed an agreement specifically governing such use. Buyers represent that they have all necessary expertise in the safety and regulatory ramifications of their applications, and acknowledge and agree that they are solely responsible for all legal, regulatory and safety-related requirements concerning their products and any use of TI products in such safety-critical applications, notwithstanding any applications-related information or support that may be provided by TI. Further, Buyers must fully indemnify TI and its representatives against any damages arising out of the use of TI products in such safety-critical applications.

TI products are neither designed nor intended for use in military/aerospace applications or environments unless the TI products are specifically designated by TI as military-grade or "enhanced plastic." Only products designated by TI as military-grade meet military specifications. Buyers acknowledge and agree that any such use of TI products which TI has not designated as military-grade is solely at the Buyer's risk, and that they are solely responsible for compliance with all legal and regulatory requirements in connection with such use.

TI products are neither designed nor intended for use in automotive applications or environments unless the specific TI products are designated by TI as compliant with ISO/TS 16949 requirements. Buyers acknowledge and agree that, if they use any non-designated products in automotive applications, TI will not be responsible for any failure to meet such requirements.

Following are URLs where you can obtain information on other Texas Instruments products and application solutions:

### Products

Amplifiers	<a href="http://amplifier.ti.com">amplifier.ti.com</a>
Data Converters	<a href="http://dataconverter.ti.com">dataconverter.ti.com</a>
DSP	<a href="http://dsp.ti.com">dsp.ti.com</a>
Clocks and Timers	<a href="http://www.ti.com/clocks">www.ti.com/clocks</a>
Interface	<a href="http://interface.ti.com">interface.ti.com</a>
Logic	<a href="http://logic.ti.com">logic.ti.com</a>
Power Mgmt	<a href="http://power.ti.com">power.ti.com</a>
Microcontrollers	<a href="http://microcontroller.ti.com">microcontroller.ti.com</a>
RFID	<a href="http://www.ti-rfid.com">www.ti-rfid.com</a>
RF/IF and ZigBee® Solutions	<a href="http://www.ti.com/lprf">www.ti.com/lprf</a>

### Applications

Audio	<a href="http://www.ti.com/audio">www.ti.com/audio</a>
Automotive	<a href="http://www.ti.com/automotive">www.ti.com/automotive</a>
Broadband	<a href="http://www.ti.com/broadband">www.ti.com/broadband</a>
Digital Control	<a href="http://www.ti.com/digitalcontrol">www.ti.com/digitalcontrol</a>
Medical	<a href="http://www.ti.com/medical">www.ti.com/medical</a>
Military	<a href="http://www.ti.com/military">www.ti.com/military</a>
Optical Networking	<a href="http://www.ti.com/opticalnetwork">www.ti.com/opticalnetwork</a>
Security	<a href="http://www.ti.com/security">www.ti.com/security</a>
Telephony	<a href="http://www.ti.com/telephony">www.ti.com/telephony</a>
Video & Imaging	<a href="http://www.ti.com/video">www.ti.com/video</a>
Wireless	<a href="http://www.ti.com/wireless">www.ti.com/wireless</a>

Mailing Address: Texas Instruments, Post Office Box 655303, Dallas, Texas 75265  
Copyright © 2008, Texas Instruments Incorporated