

## Features

- SMD Single-Turn / Cermet / Industrial Open Frame
- Cross slot rotor designs suitable for automatic adjustment equipment
- Supplied in 12 mm embossed tape, compatible with automatic pick-and-place assembly equipment
- Recommended for reflow solder processing only
- RoHS compliant\* - see [processing information](#) on lead free surface mount trimmers

# 3364 - 4 mm Square Timpot® Trimming Potentiometer

## Electrical Characteristics

Standard Resistance Range ..... 100 ohms to 1 megohm  
 (see standard resistance table)  
 Resistance Tolerance ..... ±25 % std.  
 End Resistance  
 <1K..... 20 ohms max.  
 >1K..... 2 %  
 Contact Resistance Variation  
 (Voltage Divider) ..... 5 % max.  
 Resolution ..... Infinite  
 Adjustment Angle ..... 260 ° ± 20 °

## Environmental Characteristics

Power Rating (50 volts max.)  
 70 °C ..... 0.2 watt  
 Temperature Range ... -40 °C to +100 °C  
 Temperature Coefficient ... ±250 ppm/°C  
 Humidity ..... 500 hours (5 % ΔTR)  
 Load Life..... 500 hours  
 0.2 watt @ 70 °C (5 % ΔTR)  
 Rotational Life ..... 20 cycles (15% ΔTR)

## Physical Characteristics

Torque..... 20 to 200 g-cm  
 Mechanical Angle ..... Continuous  
 Marking..... Resistance code, manufacturer's full part number and date code on packaging  
 Terminals ..... Solder coated  
 Standard Packaging... 1000 pcs./7 " reel  
 Adjustment Tool..... H-90

Reflow solder processing recommended

## How To Order

**3364 X - 1 - 103 E**

Model \_\_\_\_\_  
 Style \_\_\_\_\_  
 Orientation of parts in tape:  
 Styles W,A  
 Terminals toward sprocket holes  
 Styles X,B  
 Terminals away from sprocket holes  
 Standard Product \_\_\_\_\_  
 Resistance Code \_\_\_\_\_  
 Embossed Tape Designator  
 E = 1000 pcs./7 " reel (-1 standard)  
 G = 5000 pcs./14.5 " reel (-1 optional)

Consult factory for other available options.

## Product Dimensions

**Common Dimensions**  
**3364W, X**  
**3-Terminal**

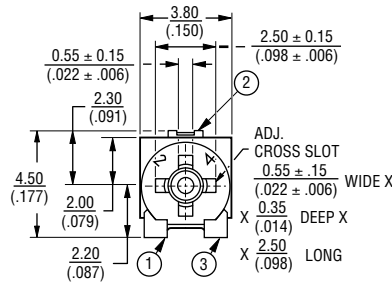

**3364A, B**  
**3-Terminal**

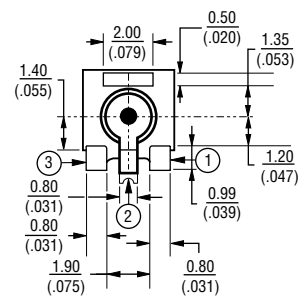
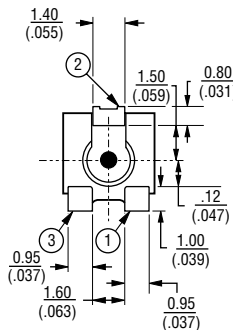
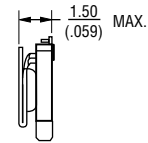
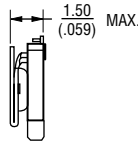
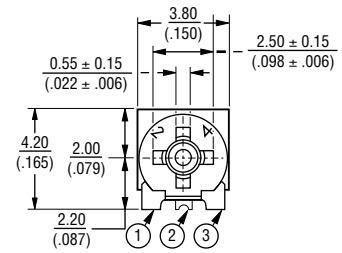

## SUGGESTED PWB LAYOUT

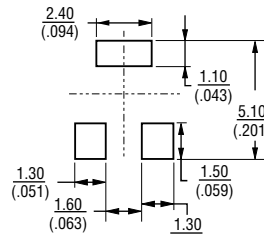

## SUGGESTED PWB LAYOUT

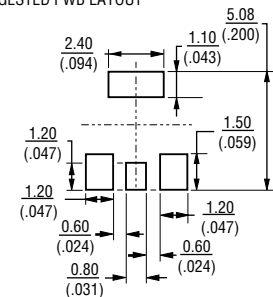

DIMENSIONS:  $\frac{\text{MM}}{\text{(INCHES)}}$   
 TOLERANCES: ±  $\frac{0.25}{(.010)}$  EXCEPT WHERE NOTED

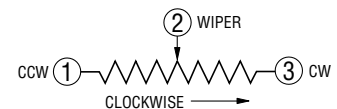

\*RoHS Directive 2002/95/EC Jan 27 2003 including Annex.  
 Specifications are subject to change without notice.  
 Customers should verify actual device performance in their specific applications.

# 3364 - 4 mm Square Trimpot® Trimming Potentiometer

**BOURNS®**

## Packaging Specifications

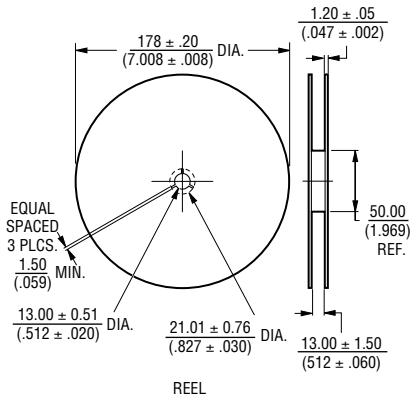
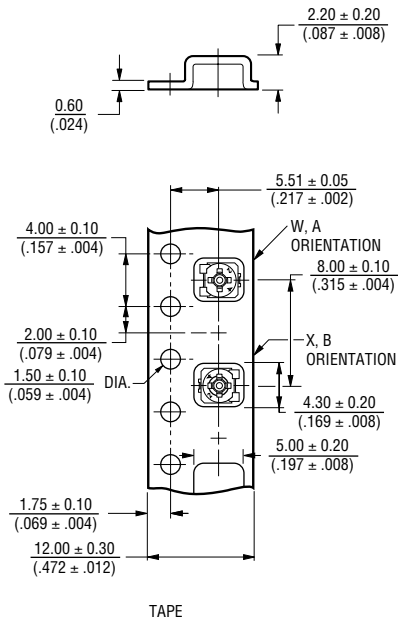

Conforms with EIA specification RS-481.

DIMENSIONS:  $\frac{\text{MM}}{\text{(INCHES)}}$

## Standard Resistance Table

Resistance (Ohms)	Resistance Code	Part Marking
<b>100</b>	<b>101</b>	<b>12</b>
<b>200</b>	<b>201</b>	<b>22</b>
<b>500</b>	<b>501</b>	<b>52</b>
<b>1,000</b>	<b>102</b>	<b>13</b>
<b>2,000</b>	<b>202</b>	<b>23</b>
<b>5,000</b>	<b>502</b>	<b>53</b>
<b>10,000</b>	<b>103</b>	<b>14</b>
<b>20,000</b>	<b>203</b>	<b>24</b>
<b>50,000</b>	<b>503</b>	<b>54</b>
<b>100,000</b>	<b>104</b>	<b>15</b>
200,000	204	25
500,000	504	55
1,000,000	105	16

Popular distribution resistance values listed in boldface.