

BTS 5434G

Smart High-Side Power Switch

PROFET

Four Channels, 60 m Ω

Automotive Power



Never stop thinking.

Table of Contents	Page
Product Summary	3
1 Overview	5
1.1 Block Diagram	5
1.2 Terms	6
2 Pin Configuration	7
2.1 Pin Assignment BTS 5434G	7
2.2 Pin Definitions and Functions	7
3 Electrical Characteristics	9
3.1 Maximum Ratings	9
4 Block Description and Electrical Characteristics	11
4.1 Power Stages	11
4.1.1 Output On-State Resistance	11
4.1.2 Input Circuit	11
4.1.3 Inductive Output Clamp	12
4.1.4 Electrical Characteristics	14
4.2 Protection Functions	16
4.2.1 Over Load Protection	16
4.2.2 Reverse Polarity Protection	17
4.2.3 Over Voltage Protection	17
4.2.4 Loss of Ground Protection	17
4.2.5 Electrical Characteristics	18
4.3 Diagnosis	19
4.3.1 ON-State Diagnosis	20
4.3.2 OFF-State Diagnosis	21
4.3.3 Sense Enable Function	22
4.3.4 Electrical Characteristics	23
5 Package Outlines BTS 5434G	25
6 Revision History	26

Smart High-Side Power Switch PROFET

BTS 5434G

Product Summary

The BTS 5434G is a four channel high-side power switch in P-DSO-28-19 package providing embedded protective functions.

The power transistor is built by a N-channel vertical power MOSFET with charge pump. The device is monolithically integrated in Smart SIPMOS technology.

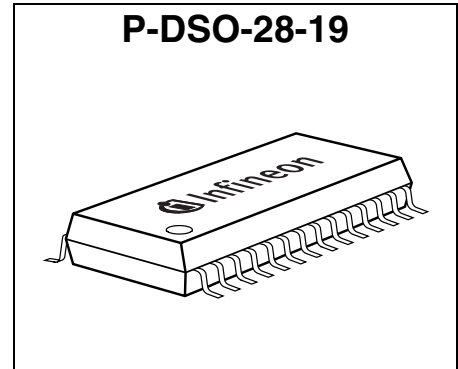

Operating voltage	$V_{bb(ON)}$	4.5 .. 28 V
Over voltage protection	$V_{bb(AZ)}$	41 V
On-State resistance	$R_{DS(ON)}$	60 m Ω
Nominal load current (one channel active)	$I_{L(nom)}$	3.4 A
Current limitation	$I_{L(LIM)}$	23 A
Current limitation repetitive	$I_{L(SCr)}$	6 A
Standby current for whole device with load	$I_{bb(OFF)}$	5 μ A

Basic Features

- Very low standby current
- 3.3 V and 5 V compatible logic pins
- Improved electromagnetic compatibility (EMC)
- Stable behavior at under voltage
- Logic ground independent from load ground
- Secure load turn-off while logic ground disconnected
- Optimized inverse current capability

Type	Ordering Code	Package
BTS 5434G	Q67060-S6157	P-DSO-28-19

Protective Functions

- Reverse battery protection without external components
- Short circuit protection
- Overload protection
- Multi-step current limitation
- Thermal shutdown with restart
- Thermal restart at reduced current limitation
- Over voltage protection without external resistor
- Loss of ground protection
- Electrostatic discharge protection (ESD)

Diagnostic Functions

- Enhanced IntelliSense signal for each channel
- Enable function for diagnosis pins (IS1 .. IS4)
- Proportional load current sense signal by current source
- High accuracy of current sense signal at wide load current range
- Open load detection in ON-state by load current sense
- Open load detection in OFF-state by voltage source
- Feedback on over temperature and current limitation in ON-state

Applications

- μ C compatible high-side power switch with diagnostic feedback for 12 V grounded loads
- All types of resistive, inductive and capacitive loads
- Suitable for loads with high inrush currents, so as lamps
- Suitable for loads with low currents, so as LEDs
- Replaces electromechanical relays, fuses and discrete circuits

1 Overview

The BTS 5434G is a four channel high-side power switch (four times 60 mΩ) in P-DSO-28-19 package providing embedded protective functions.

The Enhanced IntelliSense pins IS1 to IS4 provide a sophisticated diagnostic feedback signal including current sense function and open load in off state. The diagnosis signals can be switched on and off by the sense enable pins SENA and SENB.

Integrated ground resistors as well as integrated resistors at each input pin (IN1, IN2, IN3, IN4, SEN) reduce external components to a minimum.

The power transistor is built by a N-channel vertical power MOSFET with charge pump. The inputs are ground referenced CMOS compatible. The device is built by two dual channel chips, monolithically integrated in Smart SIPMOS technology.

1.1 Block Diagram

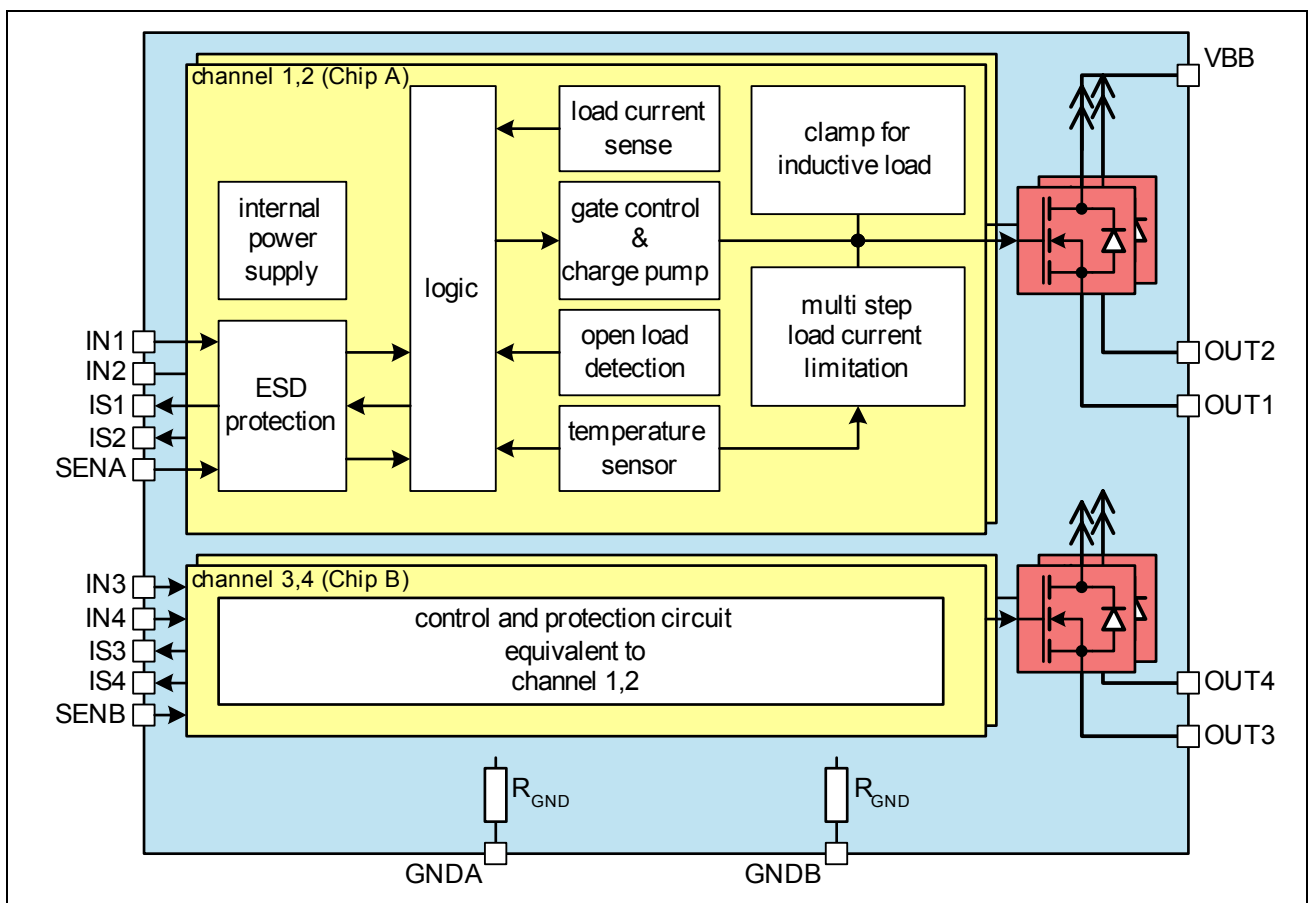

Figure 1 Block Diagram

1.2 Terms

Following figure shows all terms used in this data sheet.

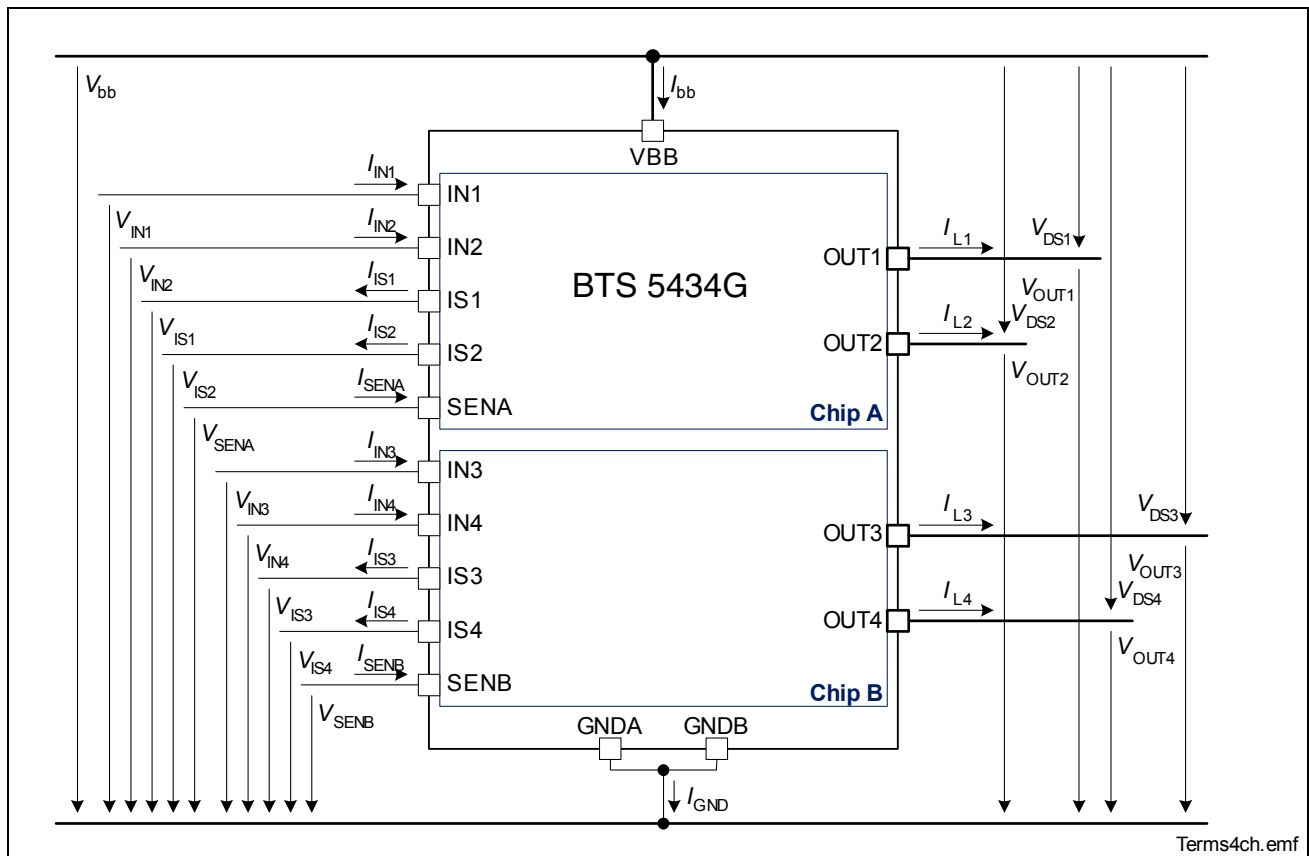

Figure 2 Terms

2 Pin Configuration

2.1 Pin Assignment BTS 5434G

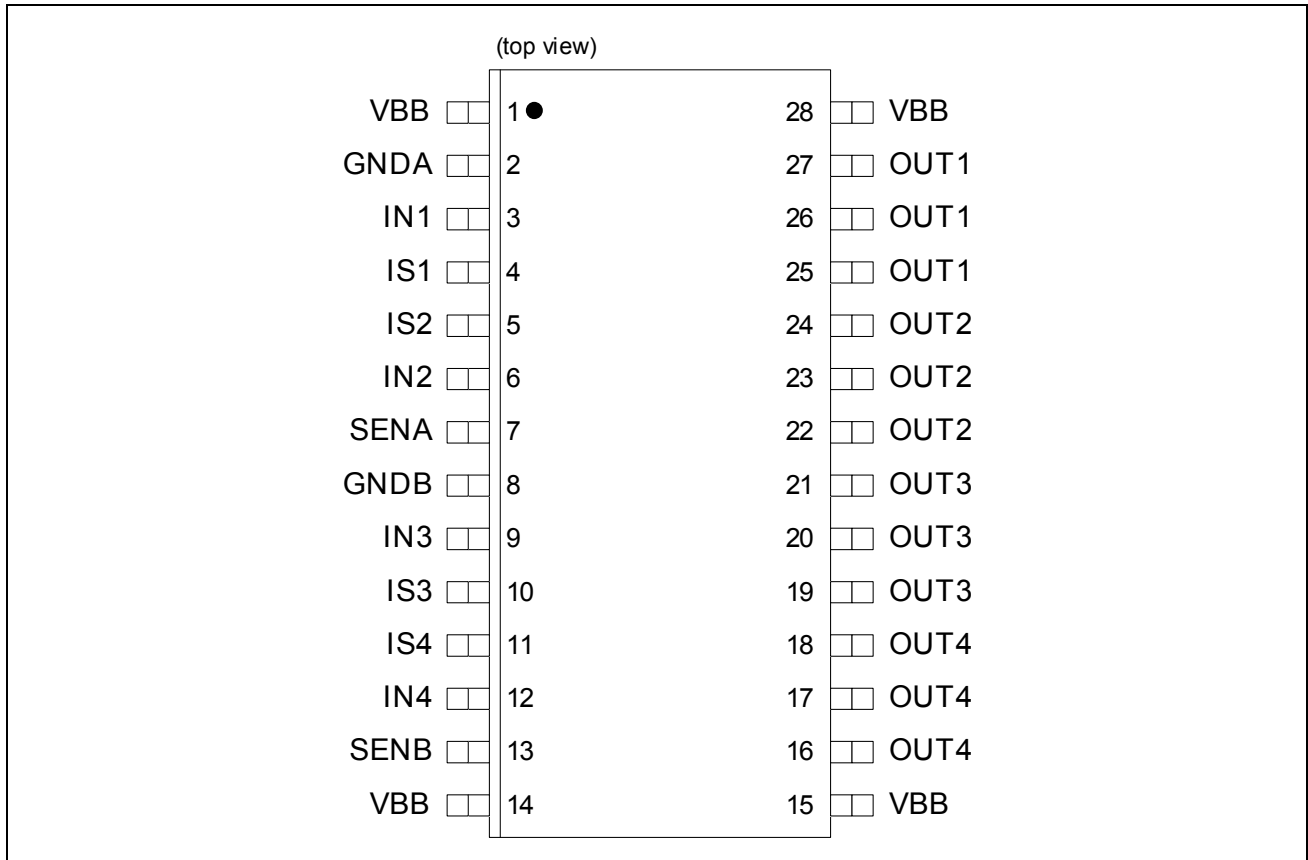

Figure 3 Pin Configuration P-DSO-28-19

2.2 Pin Definitions and Functions

Pin	Symbol	I/O OD	Function
3	IN1	I	Input signal for channel 1
6	IN2	I	Input signal for channel 2
9	IN3	I	Input signal for channel 3
12	IN4	I	Input signal for channel 4
4	IS1	O	Diagnosis output signal channel 1
5	IS2	O	Diagnosis output signal channel 2
10	IS3	O	Diagnosis output signal channel 3
11	IS4	O	Diagnosis output signal channel 4

Pin Configuration

Pin	Symbol	I/O OD	Function
7	SENA	I	Sense Enable input for channel 1&2
13	SENB	I	Sense Enable input for channel 3&4
25, 26, 27	OUT1	O	Protected high-side power output channel 1
22, 23, 24	OUT2	O	Protected high-side power output channel 2
19, 20, 21	OUT3	O	Protected high-side power output channel 3
16, 17, 18	OUT4	O	Protected high-side power output channel 4
2	GNDA	-	Ground connection chip A
8	GNDB	-	Ground connection chip B
1, 14, 15, 28	VBB	-	Positive power supply for logic supply as well as output power supply

3 Electrical Characteristics

3.1 Maximum Ratings

Stresses above the ones listed here may affect device reliability or may cause permanent damage to the device.

Unless otherwise specified:

$$T_j = 25\text{ °C}$$

Pos.	Parameter	Symbol	Limit Values		Unit	Test Conditions
			min.	max.		

Supply Voltage

3.1.1	Supply voltage	V_{bb}	-16	28	V	
3.1.2	Supply voltage for full short circuit protection (single pulse) ($T_{j(0)} = -40\text{ °C} \dots 150\text{ °C}$)	$V_{bb(SC)}$	0	28	V	$L = 8\ \mu\text{H}$, $R = 0.2\ \Omega$ ¹⁾
3.1.3	Voltage at power transistor	V_{DS}	-	52	V	
3.1.4	Supply Voltage for Load Dump protection	$V_{bb(LD)}$		41	V	$R_I = 2\ \Omega$ ²⁾ $R_L = 6.8\ \Omega$

Power Stages

3.1.5	Load current	I_L	-	$I_{L(LIM)}$	A	- ³⁾
3.1.6	Maximum energy dissipation single pulse	E_{AS}	-	0.58	J	$I_{L(0)} = 2\ \text{A}$ ⁴⁾ $T_{j(0)} = 150\text{ °C}$
3.1.7	Power dissipation (DC)	P_{tot}	-	1.7	W	$T_a = 85\text{ °C}$ ⁵⁾ $T_j \leq 150\text{ °C}$

Logic Pins

3.1.8	Voltage at input pin	V_{IN}	-5 -16	10	V	$t \leq 2\ \text{min}$
3.1.9	Current through input pin	I_{IN}	-2.0 -8.0	2.0	mA	$t \leq 2\ \text{min}$
3.1.10	Voltage at sense enable pin	V_{SEN}	-5 -16	10	V	$t \leq 2\ \text{min}$
3.1.11	Current through sense enable pin	I_{SEN}	-2.0 -8.0	2.0	mA	$t \leq 2\ \text{min}$
3.1.12	Current through sense pin	I_{IS}	-25	10	mA	

Electrical Characteristics

Unless otherwise specified:

$$T_j = 25\text{ }^\circ\text{C}$$

Pos.	Parameter	Symbol	Limit Values		Unit	Test Conditions
			min.	max.		

Temperatures

3.1.13	Junction Temperature	T_j	-40	150	°C	
3.1.14	Dynamic temperature increase while switching	ΔT_j	-	60	°C	
3.1.15	Storage Temperature	T_{stg}	-55	150	°C	

ESD Susceptibility

3.1.16	ESD susceptibility HBM	V_{ESD}			kV	according to EIA/JESD 22-A 114B
	IN, SEN		-1	1		
	IS		-2	2		
	OUT		-4	4		

- 1) R and L describe the complete circuit impedance including line, contact and generator impedances
- 2) Load Dump is specified in ISO 7636, R_l is the internal resistance of the Load Dump pulse generator
- 3) Current limitation is a protection feature. Operation in current limitation is considered as "outside" normal operating range. Protection features are not designed for continuous repetitive operation.
- 4) Pulse shape represents inductive switch off: $I_L(t) = I_L(0) * (1 - t / t_{peak}); 0 < t < t_{peak}$
- 5) Device mounted on PCB (50 mm x 50 mm x 1.5mm epoxy, FR4) with 6 cm² copper heatsinking area (one layer, 70 μm thick) for V_{bb} connection. PCB is vertical without blown air.

4 Block Description and Electrical Characteristics

4.1 Power Stages

The power stages are built by a N-channel vertical power MOSFET (DMOS) with charge pump.

4.1.1 Output On-State Resistance

The on-state resistance $R_{DS(ON)}$ depends on the supply voltage as well as the junction temperature T_j . **Figure 4** shows that dependencies for the typical on-state resistance. The behavior in reverse polarity mode is described in **Section 4.2.2**.

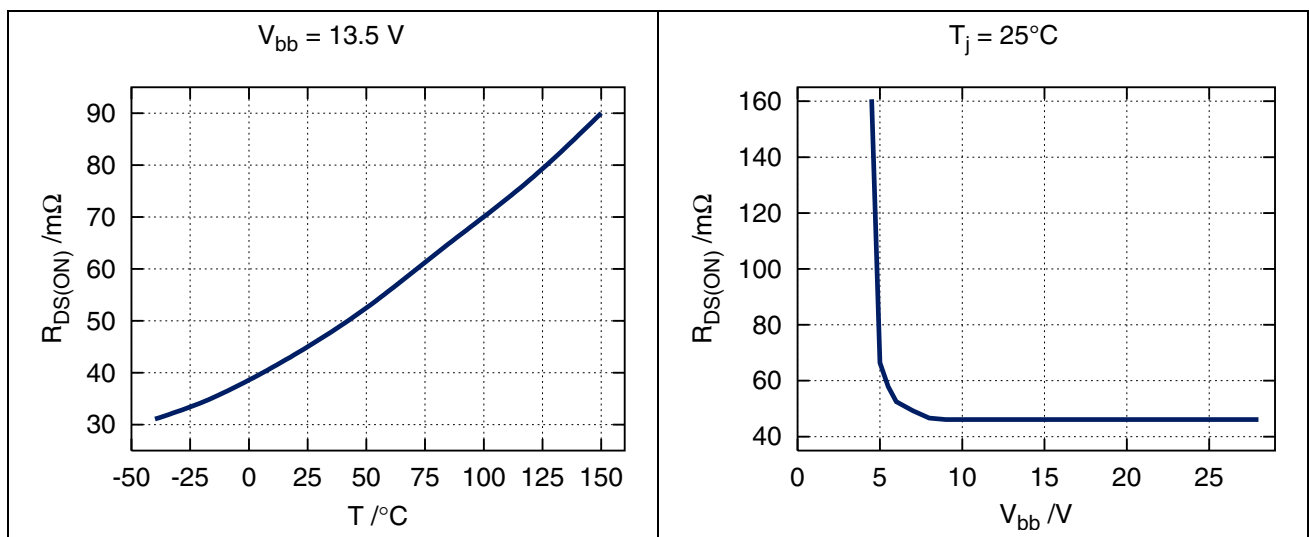

Figure 4 Typical On-State Resistance

4.1.2 Input Circuit

Figure 5 shows the input circuit of the BTS 5434G. There is an integrated input resistor that makes external components obsolete. The current sink to ground ensures that the device switches off in case of open input pin. The zener diode protects the input circuit against ESD pulses.

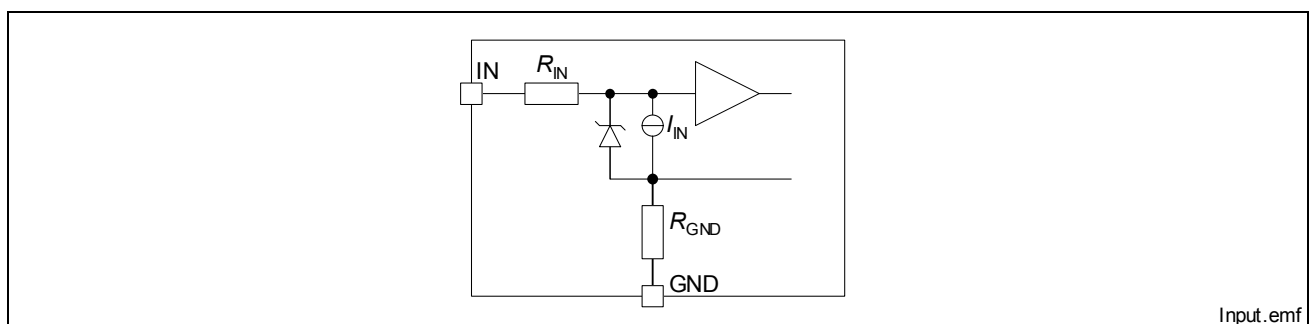

Figure 5 Input Circuit (IN1 .. IN4)

Block Description and Electrical Characteristics

A high signal at the input pin causes the power DMOS to switch on with a dedicated slope, which is optimized in terms of EMC emission.

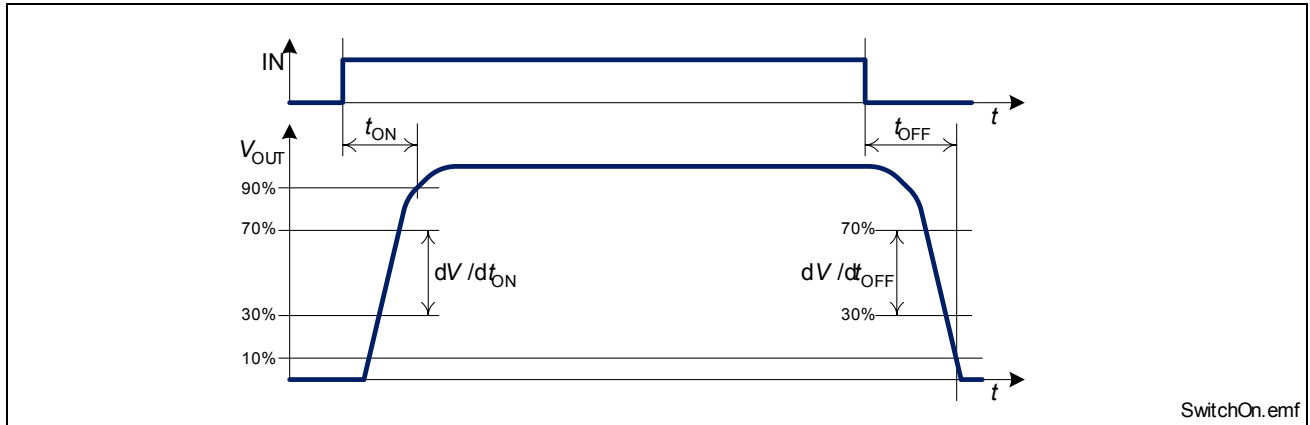

Figure 6 Switching a Load (resistive)

4.1.3 Inductive Output Clamp

When switching off inductive loads with high-side switches, the voltage V_{OUT} drops below ground potential, because the inductance intends to continue driving the current.

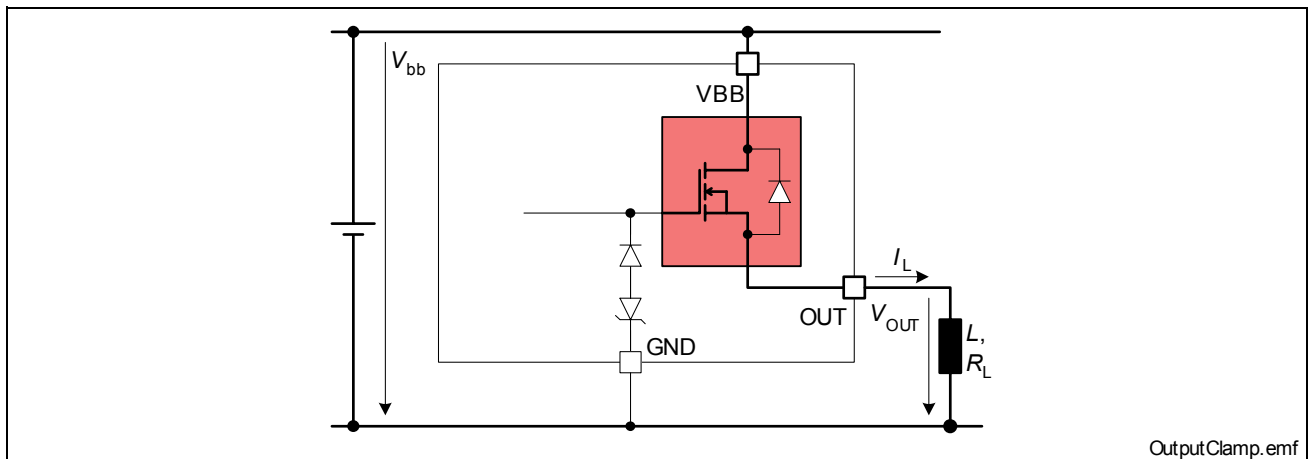

Figure 7 Output Clamp (OUT1 .. OUT4)

To prevent destruction of the device, there is a voltage clamp mechanism implemented that keeps that negative output voltage at a certain level ($V_{OUT(CL)}$). See [Figure 7](#) and [Figure 8](#) for details. Nevertheless, the maximum allowed load inductance is limited.

Block Description and Electrical Characteristics

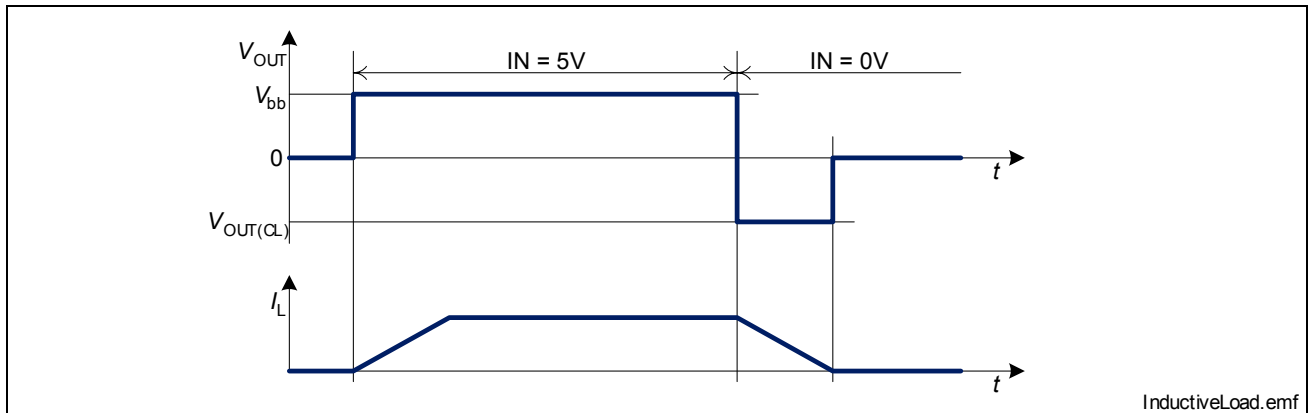

Figure 8 Switching an Inductance

Maximum Load Inductance

While demagnetization of inductive loads, energy has to be dissipated in the BTS 5434G. This energy can be calculated with following equation:

$$E = (V_{bb} + |V_{OUT(CL)}|) \cdot \left[\frac{|V_{OUT(CL)}|}{R_L} \cdot \ln \left(1 + \frac{R_L \cdot I_L}{|V_{OUT(CL)}|} \right) + I_L \right] \cdot \frac{L}{R_L}$$

Following equation simplifies under the assumption of $R_L = 0$:

$$E = \frac{1}{2} L I_L^2 \cdot \left(1 + \frac{V_{bb}}{|V_{OUT(CL)}|} \right)$$

The energy, which is converted into heat, is limited by the thermal design of the component. See [Figure 9](#) for the maximum allowed energy dissipation.

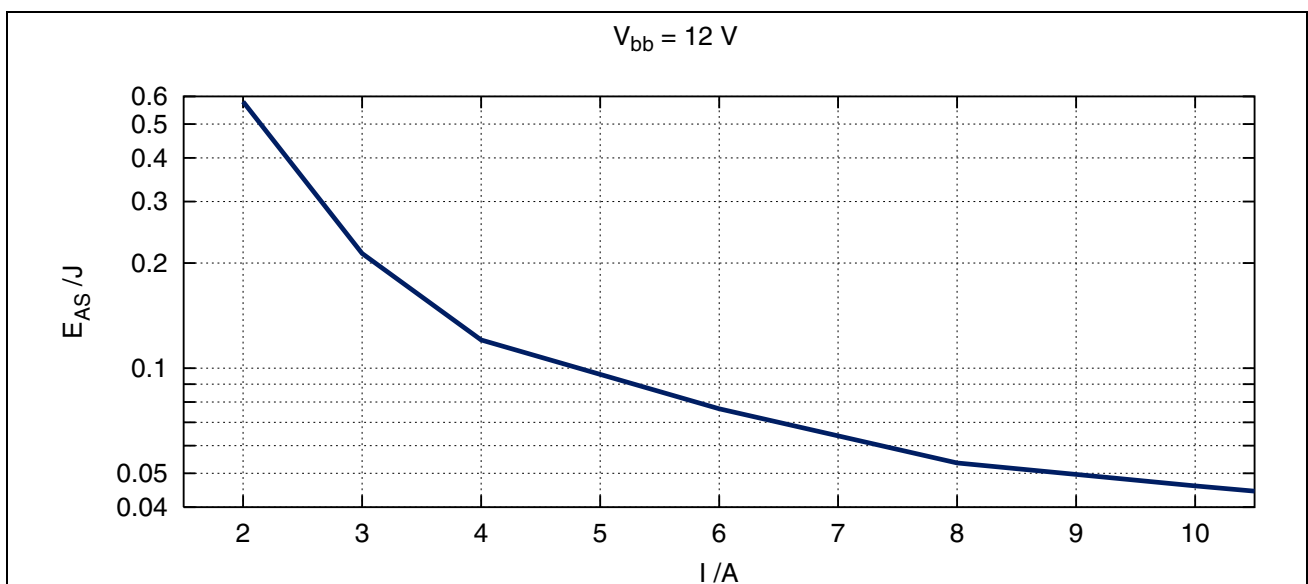

Figure 9 Maximum energy dissipation single pulse, $T_{j,Start} = 150^\circ\text{C}$

Block Description and Electrical Characteristics

4.1.4 Electrical Characteristics

Unless otherwise specified:

$V_{bb} = 9\text{ V to }16\text{ V}$, $T_j = -40\text{ °C to }+150\text{ °C}$, typical values: $V_{bb} = 13.5\text{ V}$, $T_j = 25\text{ °C}$

Pos.	Parameter	Symbol	Limit Values			Unit	Test Conditions
			min.	typ.	max.		

General

4.1.1	Operating voltage	V_{bb}	4.5		28	V	$V_{IN} = 4.5\text{ V}$ $R_L = 12\ \Omega$ $V_{DS} < 0.5\text{ V}$
4.1.2	Operating current one channel active all channels active	I_{GND}		1.8 7.2	4 16	mA	$V_{IN} = 5\text{ V}$
4.1.3	Standby current for whole device with load	$I_{bb(OFF)}$		3	5 5 30	μA	$V_{IN} = 0\text{ V}$ $V_{SEN} = 0\text{ V}$ $T_j = 25\text{ °C}$ $T_j = 85\text{ °C}^{1)}$ $T_j = 150\text{ °C}$

Output characteristics

4.1.4	On-State resistance per channel	$R_{DS(ON)}$		45 90	60 115	m Ω	$I_L = 2.5\text{ A}$ $T_j = 25\text{ °C}$ $T_j = 150\text{ °C}$
4.1.5	Output voltage drop limitation at small load currents	$V_{DS(NL)}$		40		mV	$I_L < 0.25\text{ A}$
4.1.6	Nominal load current per channel one channel active four channels active	$I_{L(nom)}$		3.4 1.9		A	$T_a = 85\text{ °C}$ $T_j \leq 150\text{ °C}^{2) 3)}$
4.1.7	Output clamp	$V_{OUT(CL)}$	-16	-13	-10	V	$I_L = 40\text{ mA}$
4.1.8	Output leakage current per channel	$I_{L(OFF)}$		0.1	6	μA	$V_{IN} = 0\text{ V}$
4.1.9	Inverse current capability	$-I_{L(inv)}$		3		A	¹⁾

Block Description and Electrical Characteristics

Unless otherwise specified:

$V_{bb} = 9\text{ V to }16\text{ V}$, $T_j = -40\text{ °C to }+150\text{ °C}$, typical values: $V_{bb} = 13.5\text{ V}$, $T_j = 25\text{ °C}$

Pos.	Parameter	Symbol	Limit Values			Unit	Test Conditions
			min.	typ.	max.		

Thermal Resistance

4.1.10	Junction to case	R_{thjc}	-		30	K/W	- 1)
4.1.11	Junction to ambient one channel active all channels active	R_{thja}	- -	44 38		K/W	- 1)2)

Input characteristics

4.1.12	Input resistor	R_{IN}	1.8	3.5	5.5	k Ω	
4.1.13	L-input level	$V_{IN(L)}$	-0.3		1.0	V	
4.1.14	H-input level	$V_{IN(H)}$	2.5		5.7	V	
4.1.15	L-input current	$I_{IN(L)}$	3	18	75	μA	$V_{IN} = 0.4\text{ V}$
4.1.16	H-input current	$I_{IN(H)}$	10	38	75	μA	$V_{IN} = 5\text{ V}$

Timings

4.1.17	Turn-on time to 90% V_{bb}	t_{ON}		100	250	μs	$R_L = 12\ \Omega$ $V_{bb} = 13.5\text{ V}$
4.1.18	Turn-off time to 10% V_{bb}	t_{OFF}		120	250	μs	$R_L = 12\ \Omega$ $V_{bb} = 13.5\text{ V}$
4.1.19	slew rate 30% to 70% V_{bb}	dV/dt_{ON}	0.1	0.25	0.5	V/ μs	$R_L = 12\ \Omega$ $V_{bb} = 13.5\text{ V}$
4.1.20	slew rate 70% to 30% V_{bb}	$-dV/dt_{OFF}$	0.1	0.25	0.5	V/ μs	$R_L = 12\ \Omega$ $V_{bb} = 13.5\text{ V}$

1) Not subject to production test, specified by design

2) Device mounted on PCB (50 mm x 50 mm x 1.5mm epoxy, FR4) with 6 cm² copper heatsinking area (one layer, 70 μm thick) for V_{bb} connection. PCB is vertical without blown air.

3) Not subject to production test, parameters are calculated from $R_{DS(ON)}$ and R_{th}

Note: Characteristics show the deviation of parameter at the given supply voltage and junction temperature. Typical values show the typical parameters expected from manufacturing.

4.2 Protection Functions

The device provides embedded protective functions. Integrated protection functions are designed to prevent IC destruction under fault conditions described in the data sheet. Fault conditions are considered as “outside” normal operating range. Protection functions are neither designed for continuous nor repetitive operation.

4.2.1 Over Load Protection

The load current I_{OUT} is limited by the device itself in case of over load or short circuit to ground. There are three steps of current limitation which are selected automatically depending on the voltage V_{DS} across the power DMOS. Please note that the voltage at the OUT pin is $V_{bb} - V_{DS}$. Please refer to following figure for details.

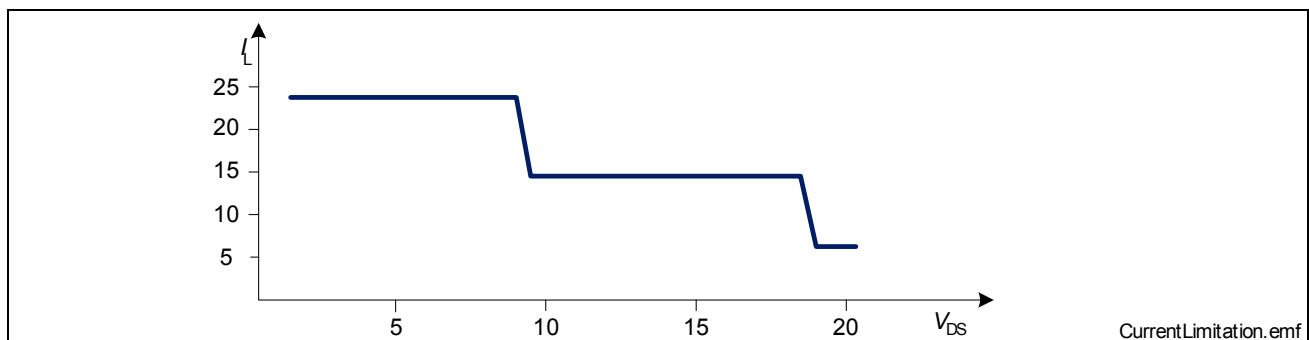

Figure 10 Current Limitation (minimum values)

Current limitation is realized by increasing the resistance of the device which leads to rapid temperature rise inside. A temperature sensor for each channel causes an overheated channel to switch off to prevent destruction. After cooling down with thermal hysteresis, the channel switches on again. Please refer to [Figure 11](#) for details.

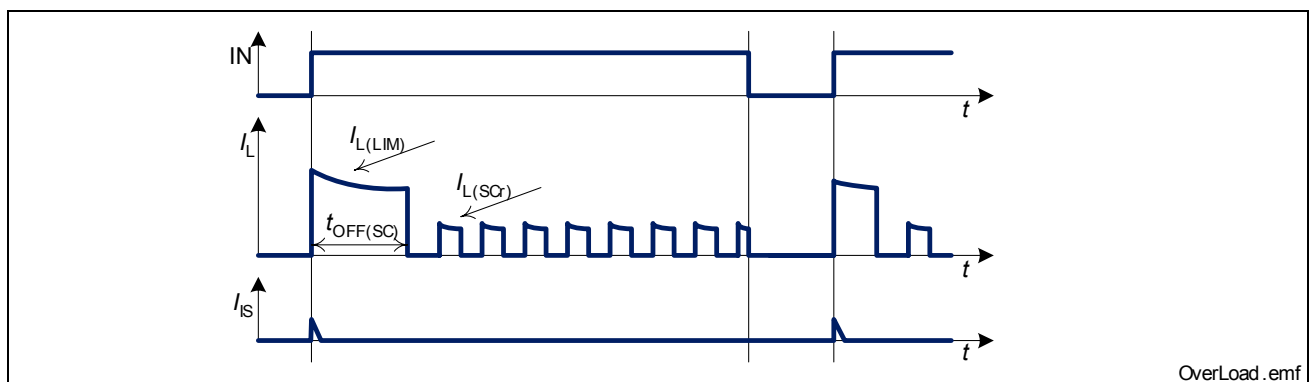

Figure 11 Shut Down by Over Temperature with Current Limitation

In short circuit condition, the load current is initially limited to $I_{L(LIM)}$. After thermal restart, the current limitation level is reduced to $I_{L(SCr)}$. The current limitation level is reset to $I_{L(LIM)}$ by switching off the device ($V_{IN} = 0$ V).

4.2.2 Reverse Polarity Protection

In case of reverse polarity, the intrinsic body diode causes power dissipation. Additional power is dissipated by the integrated ground resistor. Use following formula for estimation of total power dissipation $P_{\text{diss(rev)}}$ in reverse polarity mode.

$$P_{\text{diss(rev)}} = \sum_{\text{all channels}} (V_{\text{DS(rev)}} \cdot I_{\text{L}}) + 2 \frac{V_{\text{bb}}^2}{R_{\text{GND}}}$$

The reverse current through the intrinsic body diode has to be limited by the connected load. The current through sense pins IS1 to IS4 has to be limited (please refer to maximum ratings on [Page 9](#)). The current through the ground pin (GND) is limited internally by R_{GND} . The over-temperature protection is not active during reverse polarity.

4.2.3 Over Voltage Protection

In addition to the output clamp for inductive loads as described in [Section 4.1.3](#), there is a clamp mechanism for over voltage protection. Because of the integrated ground resistor, over voltage protection does not require external components.

As shown in [Figure 12](#), in case of supply voltages greater than $V_{\text{bb(AZ)}}$, the power transistor switches on and the voltage across logic part is clamped. As a result, the internal ground potential rises to $V_{\text{bb}} - V_{\text{bb(AZ)}}$. Due to the ESD zener diodes, the potential at pin IN1, IN2 and SEN rises almost to that potential, depending on the impedance of the connected circuitry.

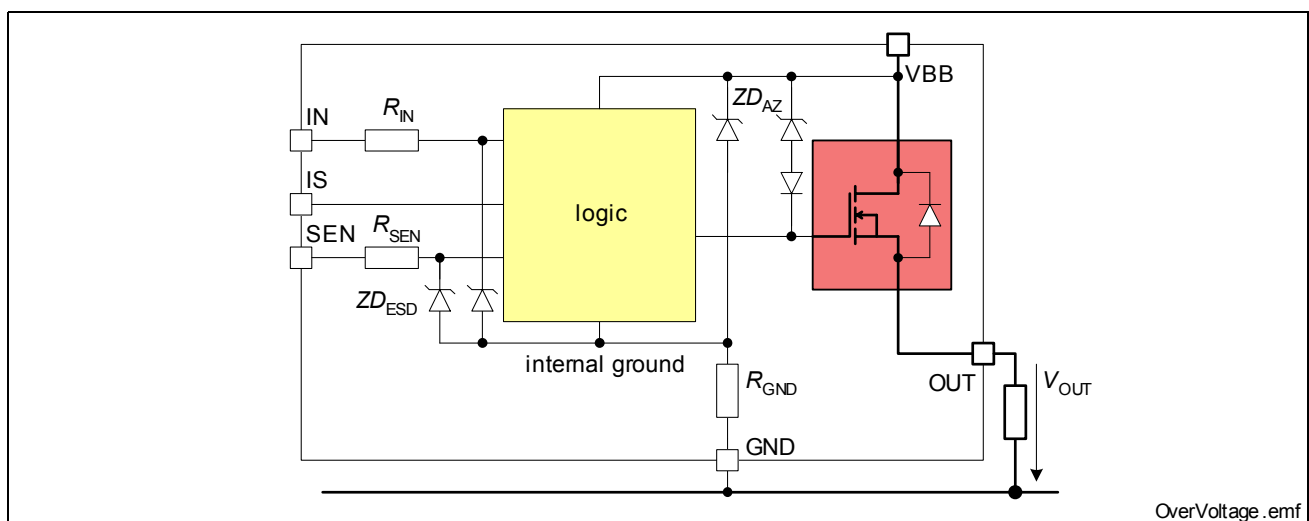

Figure 12 Over Voltage Protection

4.2.4 Loss of Ground Protection

In case of complete loss of the device ground connections, but connected load ground, the BTS 5434G securely changes to or keeps in off state.

4.2.5 Electrical Characteristics

Unless otherwise specified:

$V_{bb} = 9\text{ V to }16\text{ V}$, $T_j = -40\text{ °C to }+150\text{ °C}$, typical values: $V_{bb} = 13.5\text{ V}$, $T_j = 25\text{ °C}$

Pos.	Parameter	Symbol	Limit Values			Unit	Test Conditions
			min.	typ.	max.		

Over Load Protection

4.2.1	Load current limitation	$I_{L(LIM)}$	23		42	A	$V_{DS} = 7\text{ V}$
			14		28	A	$V_{DS} = 14\text{ V}$
4.2.2	Repetitive short circuit current limitation	$I_{L(SCr)}$		6		A	$T_j = T_{j(SC)}^{1)}$
4.2.3	Initial short circuit shut down time	$t_{OFF(SC)}$		0.5		ms	$T_{jStart} = 25\text{ °C }^{1)}$
4.2.4	Thermal shut down temperature	$T_{j(SC)}$	150	170 ¹⁾		°C	-
4.2.5	Thermal hysteresis	ΔT_j		7		K	- ¹⁾

Reverse Battery

4.2.6	Drain-Source diode voltage ($V_{OUT} > V_{bb}$)	$-V_{DS(rev)}$			900	mV	$I_L = -3.5\text{ A}$ $V_{bb} = -13.5\text{ V}$ $T_j = 150\text{ °C}$
4.2.7	Reverse current through each GND pin	$-I_{GND}$		65		mA	$V_{bb} = -13.5\text{ V }^{1)}$

Ground Circuit

4.2.8	Integrated Resistors in GND lines	R_{GND}	115	220	350	Ω	
-------	-----------------------------------	-----------	-----	-----	-----	----------	--

Over Voltage

4.2.9	Over voltage protection	$V_{bb(AZ)}$	41	47	53	V	$I_{bb} = 4\text{ mA}$
-------	-------------------------	--------------	----	----	----	---	------------------------

Loss of GND

4.2.10	Output leakage current while GND disconnected	$I_{L(GND)}$			1	mA	$I_{IN} = 0, I_{SEN} = 0,$ $I_{IS} = 0,$ $I_{GND} = 0^{1) 2)}$
--------	---	--------------	--	--	---	----	--

¹⁾ Not subject to production test, specified by design

²⁾ no connection at these pins

4.3 Diagnosis

For diagnosis purpose, the BTS 5434G provides an Enhanced IntelliSense signal at pins IS1 to IS4. This means in detail, the current sense signal I_{IS} , a proportional signal to the load current (ratio $k_{ILIS} = I_L / I_{IS}$), is provided in ON-state as long as no failure mode occurs. In case of open load in OFF-state, the voltage $V_{IS(fault)}$ is fed to the diagnosis pin.

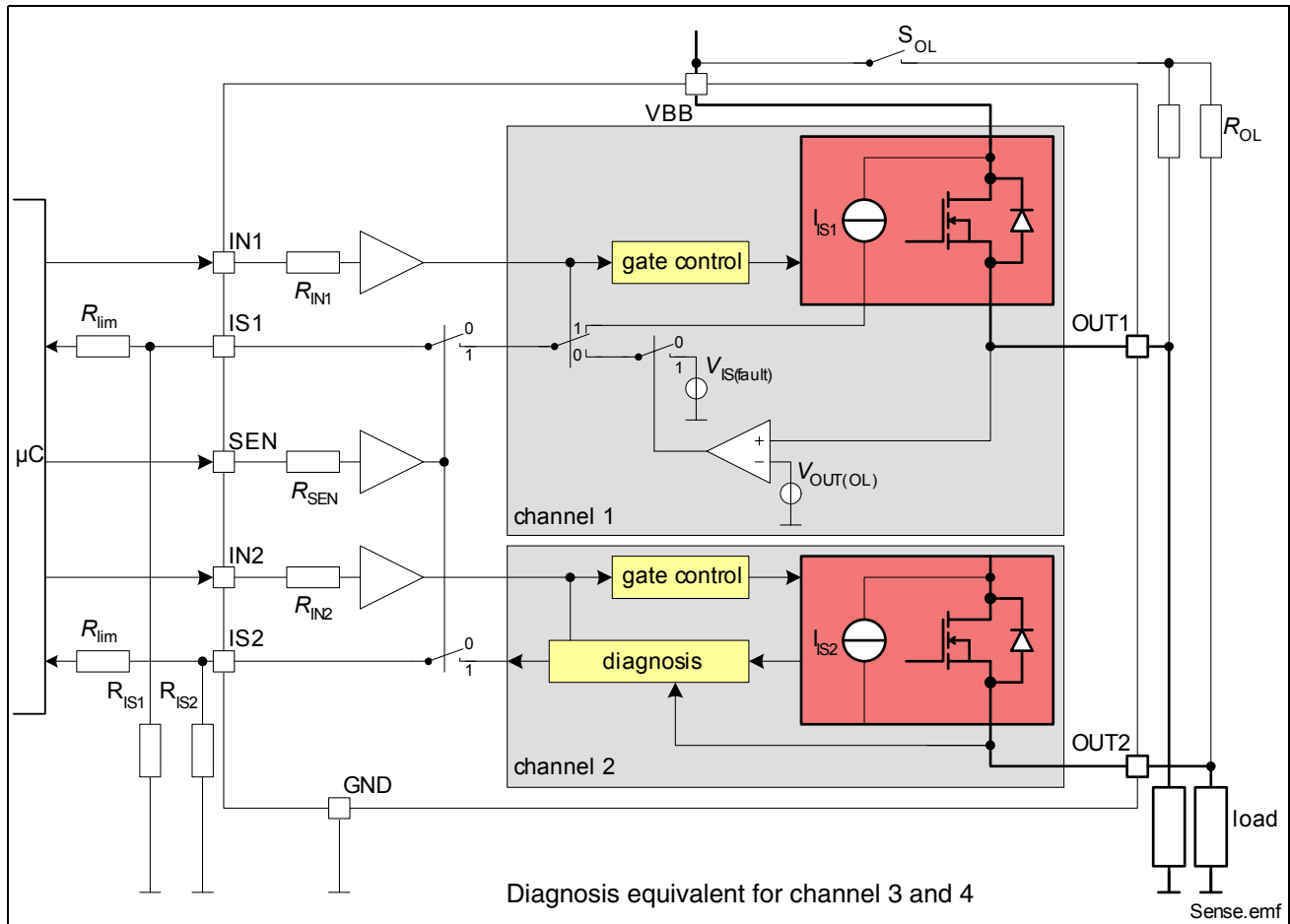

Figure 13 Block Diagram: Diagnosis

Table 1 Truth Table

Operation Mode	Input Level	Output Level	Diagnostic Output	
			SEN = H	SEN = L
Normal Operation (OFF)	L	Z	Z	Z
Short Circuit to GND		Z	Z	Z
Over Temperature		Z	Z	Z
Short Circuit to V_{bb}		V_{bb}	$V_{IS} = V_{IS(fault)}$	Z
Open Load		$< V_{OUT(OL)}$	Z	Z
		$> V_{OUT(OL)}$	$V_{IS} = V_{IS(fault)}$	Z

Table 1 Truth Table

Operation Mode	Input Level	Output Level	Diagnostic Output	
			SEN = H	SEN = L
Normal Operation (ON)	H	$\sim V_{bb}$	$I_{IS} = I_L / k_{ILIS}$	Z
Current Limitation		$< V_{bb}$	Z	Z
Short Circuit to GND		$\ll V_{bb}$	Z	Z
Over Temperature		Z	Z	Z
Short Circuit to V_{bb}		V_{bb}	$I_{IS} < I_L / k_{ILIS}$	Z
Open Load		$\sim V_{bb}$	Z	Z

L = Low Level, H = High Level, Z = high impedance, potential depends on leakage currents and external circuit

4.3.1 ON-State Diagnosis

The standard diagnosis signal is a current sense signal proportional to the load current. The accuracy of the ratio ($k_{ILIS} = I_L / I_{IS}$) depends on the temperature. Please refer to following [Figure 14](#) for details. Usually a resistor R_{IS} is connected to the current sense pin. It is recommended to use sense resistors $R_{IS} > 500 \Omega$. A typical value is 4.7 k Ω .

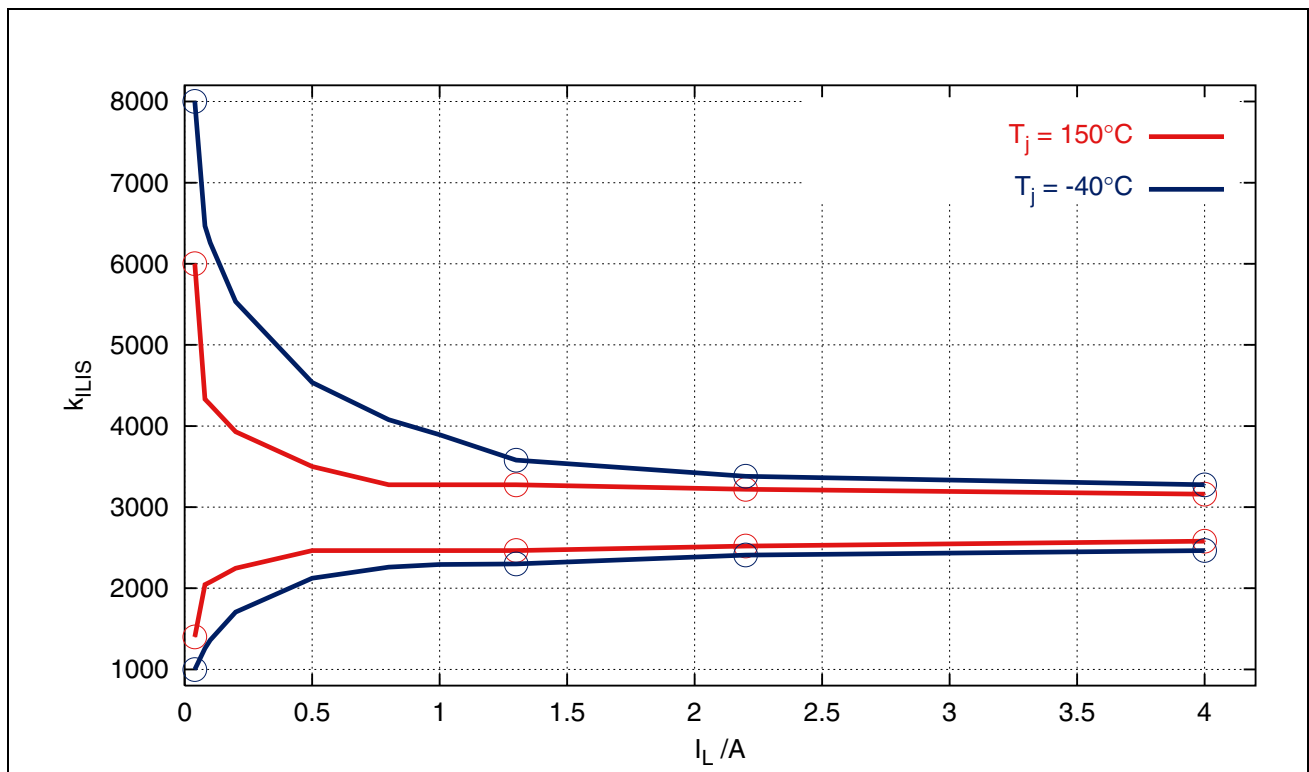

Figure 14 Current sense ratio k_{ILIS} ¹⁾

¹⁾ The curves show the behavior based on characterization data. The marked points are guaranteed in this Data Sheet in [Section 4.3.4](#) (Position [4.3.6](#)).

In case of over current as well as over temperature, the current sense signal is switched off. As a result, one threshold is enough to distinguish between normal and faulty operation. Open load and over load can be differentiated by switching off the channel and using open load detection in off-state.

Details about timings between the diagnosis signal I_{IS} and the output voltage V_{OUT} and load current I_L in ON-state can be found in **Figure 15**.

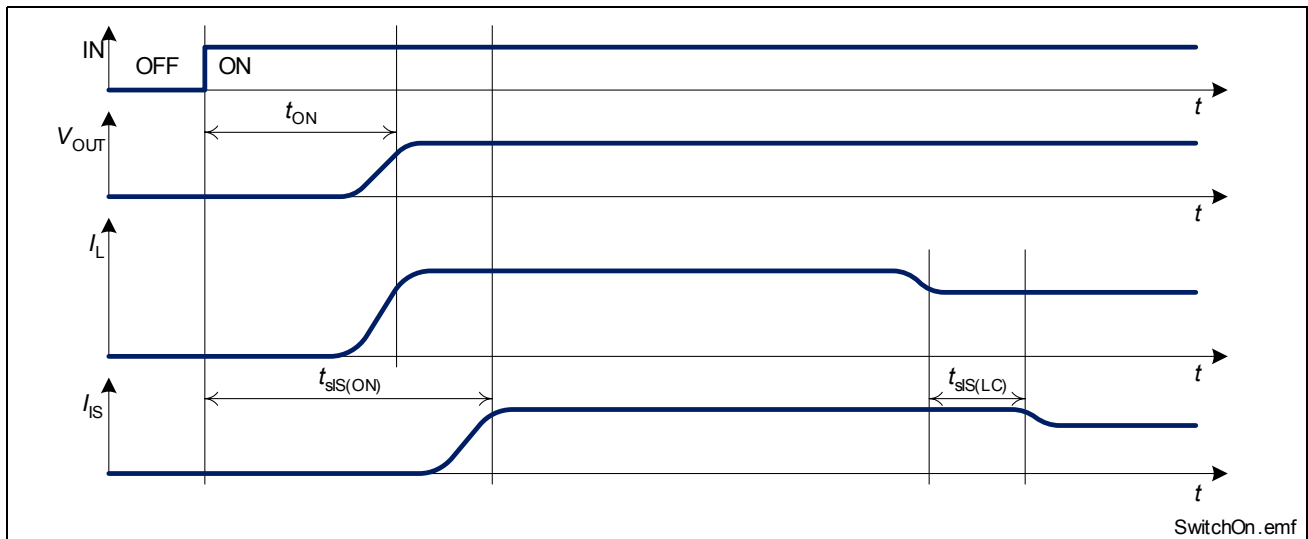

Figure 15 Timing of Diagnosis Signal in ON-state

4.3.2 OFF-State Diagnosis

Details about timings between the diagnosis signal I_{IS} and the output voltage V_{OUT} and load current I_L in OFF-state can be found in **Figure 16**.

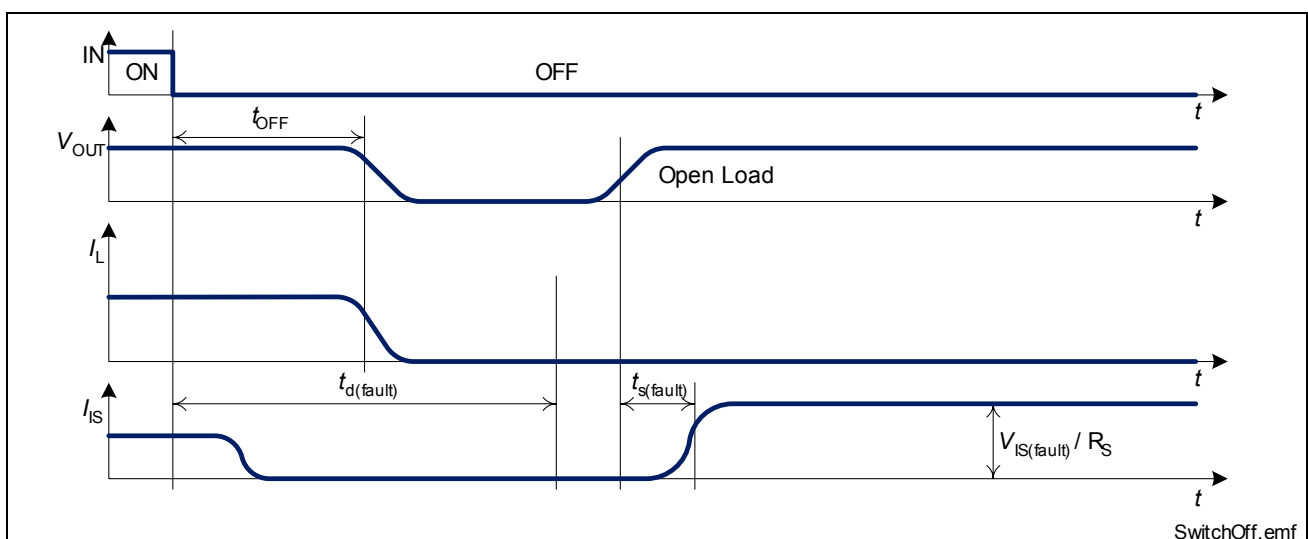

Figure 16 Timing of Diagnosis Signal in OFF-state

For open load diagnosis in off state an external output pull-up resistor (R_{OL}) is recommended. For calculation of the pull-up resistor, just the external leakage current $I_{leakage}$ and the open load threshold voltage $V_{OUT(OL)}$ has to be taken into account.

$$R_{OL} = \frac{V_{bb(min)} - V_{OUT(OL,max)}}{I_{leakage}}$$

$I_{leakage}$ defines the leakage current in the complete system e.g. caused by humidity. There is no internal leakage current from out to ground at BTS 5434G. $V_{bb(min)}$ is the minimum supply voltage at which the open load diagnosis in off state must be ensured. To reduce the stand-by current of the system, an open load resistor switch (S_{OL}) is recommended.

4.3.3 Sense Enable Function

The diagnosis signals have to be switched on by a high signal at sense enable pin (SEN). See [Figure 17](#) for details on the timing between SEN pin and diagnosis signal I_{IS} . Please note that the diagnosis is disabled, when no signal is provided at pin SEN.

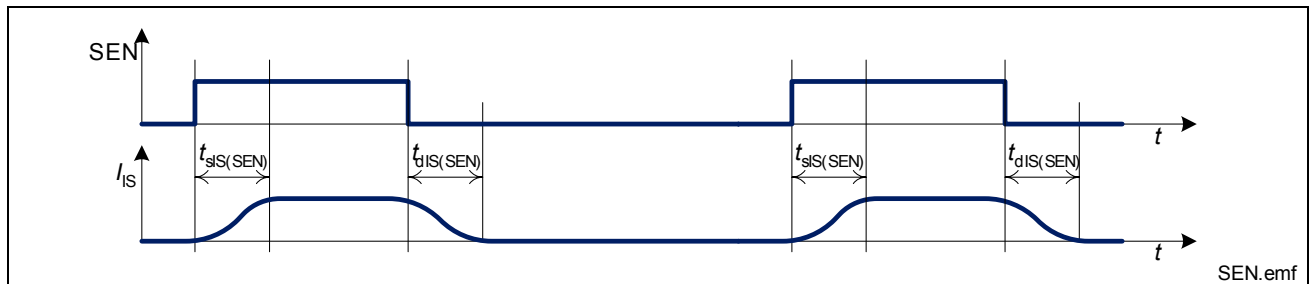

Figure 17 Timing of Sense Enable Signal

The SEN pin circuit is designed equal to the input pin. Please refer to [Figure 5](#) for details. The resistors R_{lim} are recommended to limit the current through the sense pins IS1 to IS4 in case of reverse polarity and over voltage. Please refer to maximum ratings on [Page 9](#).

The stand-by current of the BTS 5434G is minimized, when both input pins (IN1 and IN2 or IN3 and IN4) and the according sense enable pin (SENA or SENB) are on low level.

4.3.4 Electrical Characteristics

Unless otherwise specified:

$V_{bb} = 9\text{ V to }16\text{ V}$, $T_j = -40\text{ °C to }+150\text{ °C}$, $V_{SEN} = 5\text{ V}$,
typical values: $V_{bb} = 13.5\text{ V}$, $T_j = 25\text{ °C}$

Pos.	Parameter	Symbol	Limit Values			Unit	Test Conditions
			min.	typ.	max.		

Open Load at OFF-State

4.3.1	Open load detection threshold voltage	$V_{OUT(OL)}$	1.6	2.8	4.4	V	
4.3.2	Sense signal in case of open load	$V_{IS(fault)}$	3.5		6.5	V	$V_{IN} = 0\text{ V}$ $V_{OUT} = V_{bb}$ $I_{IS} = 1\text{ mA}$
4.3.3	Sense signal current limitation	$I_{IS(LIM)}$	2			mA	$V_{IN} = 0\text{ V}$ $V_{OUT} = V_{bb}$
4.3.4	Sense signal invalid after negative input slope	$t_{d(fault)}$			1.2	ms	$V_{IN} = 5\text{ V to }0\text{ V}$ $V_{OUT} = V_{bb}$
4.3.5	Fault signal settling time	$t_{s(fault)}$			200	μs	$V_{IN} = 0\text{ V}$ $V_{OUT} = 0\text{ V to } > V_{OUT(OL)}$ $I_{IS} = 1\text{ mA}$

Load Current Sense ON-State

4.3.6	Current sense ratio	k_{ILIS}					$V_{IN} = 5\text{ V}$ $T_j = -40\text{ °C}$
	$I_L = 40\text{ mA}$		1000	4035	8000		
	$I_L = 1.3\text{ A}$		2300	3050	3580		
	$I_L = 2.2\text{ A}$		2410	2920	3380		
	$I_L = 4.0\text{ A}$		2465	2850	3275		
	$I_L = 40\text{ mA}$		1400	3410	6000		$T_j = 150\text{ °C}$
	$I_L = 1.3\text{ A}$		2465	2920	3275		
	$I_L = 2.2\text{ A}$		2520	2875	3220		
	$I_L = 4.0\text{ A}$		2580	2870	3160		
4.3.7	Current sense voltage limitation	$V_{IS(LIM)}$	5.0	6.2	7.5	V	$I_{IS} = 0.5\text{ mA}$ $I_L = 3.5\text{ A}$
4.3.8	Current sense leakage/offset current	$I_{IS(LH)}$			5	μA	$V_{IN} = 5\text{ V}$ $I_L = 0\text{ A}$

Unless otherwise specified:

$V_{bb} = 9\text{ V to }16\text{ V}$, $T_j = -40\text{ °C to }+150\text{ °C}$, $V_{SEN} = 5\text{ V}$,
typical values: $V_{bb} = 13.5\text{ V}$, $T_j = 25\text{ °C}$

Pos.	Parameter	Symbol	Limit Values			Unit	Test Conditions
			min.	typ.	max.		
4.3.9	Current sense leakage, while diagnosis disabled	$I_{IS(dis)}$			2	μA	$V_{SEN} = 0\text{ V}$ $I_L = 3.5\text{ A}$
4.3.10	Current sense settling time to I_{IS} static $\pm 10\%$ after positive input slope	$t_{sIS(ON)}$			300	μs	$V_{IN} = 0\text{ V to }5\text{ V}$ $I_L = 3.5\text{ A}$ 1)
4.3.11	Current sense settling time to I_{IS} static $\pm 10\%$ after change of load current	$t_{sIS(LC)}$			50	μs	$V_{IN} = 5\text{ V}$ $I_L = 1.3\text{ A to }2.2\text{ A}$ 1)

Sense Enable

4.3.12	Input resistance	R_{SEN}	1.8	3.5	5.5	$\text{k}\Omega$	
4.3.13	L-input level	$V_{SEN(L)}$	-0.3		1.0	V	
4.3.14	H-input level	$V_{SEN(H)}$	2.5		5.7	V	
4.3.15	L-input current	$I_{SEN(L)}$	3	18	75	μA	$V_{SEN} = 0.4\text{ V}$
4.3.16	H-input current	$I_{SEN(H)}$	10	38	75	μA	$V_{SEN} = 5\text{ V}$
4.3.17	Current sense settling time	$t_{sIS(SEN)}$		3	25	μs	$V_{SEN} = 0\text{ V to }5\text{ V}$ $V_{IN} = 0\text{ V}$ $V_{OUT} > V_{OUT(OL)}$
4.3.18	Current sense deactivation time	$t_{dIS(SEN)}$			25	μs	$V_{SEN} = 5\text{ V to }0\text{ V}$ $I_L = 3.5\text{ A}$ $R_S = 5\text{ k}\Omega$ ¹⁾

¹⁾ Not subject to production test, specified by design

5 Package Outlines BTS 5434G

P-DSO-28-19 (Plastic Dual Small Outline Package)

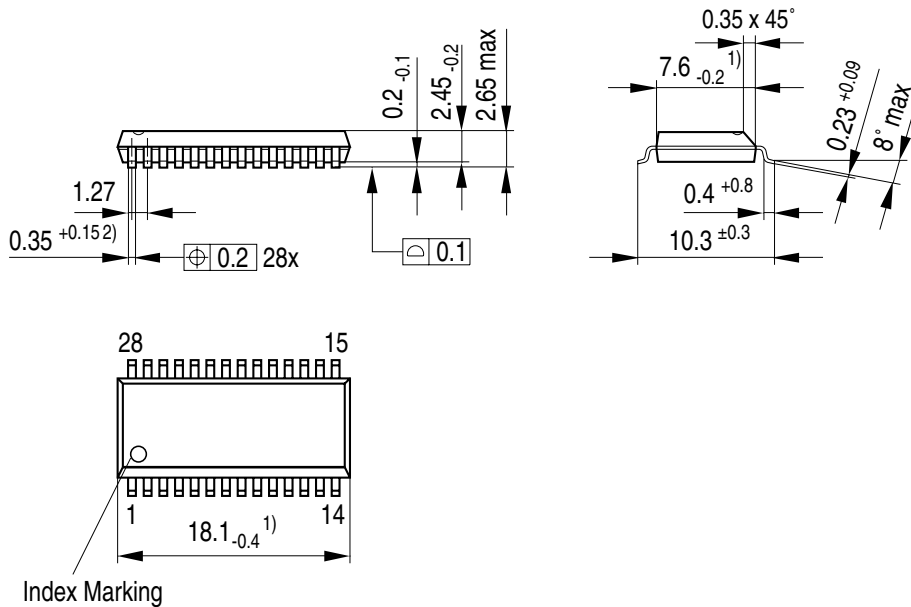

- 1) Does not include plastic or metal protrusions of 0.15 max per side
2) Does not include dambar protrusion of 0.05 max per side

GPS05123

You can find all of our packages, sorts of packing and others in our Infineon Internet Page "Products": <http://www.infineon.com/products>.

SMD = Surface Mounted Device

Dimensions in mm

6 Revision History

Version	Date	Changes
V1.0	04-01-23	initial version

Edition 2004-01-23

**Published by Infineon Technologies AG,
St.-Martin-Strasse 53,
D-81541 München, Germany**

**© Infineon Technologies AG 1/31/04.
All Rights Reserved.**

Attention please!

The information herein is given to describe certain components and shall not be considered as warranted characteristics.

Terms of delivery and rights to technical change reserved.

We hereby disclaim any and all warranties, including but not limited to warranties of non-infringement, regarding circuits, descriptions and charts stated herein.

Infineon Technologies is an approved CECC manufacturer.

Information

For further information on technology, delivery terms and conditions and prices please contact your nearest Infineon Technologies Office in Germany or our Infineon Technologies Representatives worldwide.

Warnings

Due to technical requirements components may contain dangerous substances. For information on the types in question please contact your nearest Infineon Technologies Office.

Infineon Technologies Components may only be used in life-support devices or systems with the express written approval of Infineon Technologies, if a failure of such components can reasonably be expected to cause the failure of that life-support device or system, or to affect the safety or effectiveness of that device or system. Life support devices or systems are intended to be implanted in the human body, or to support and/or maintain and sustain and/or protect human life. If they fail, it is reasonable to assume that the health of the user or other persons may be endangered.

<http://www.infineon.com>

Published by Infineon Technologies AG