

PFR Series Polypropylene Film/Foil, Radial

Overview

The PFR Series is a capacitor with polypropylene film and metal foil electrodes, encapsulated in self-extinguishing resin in a box of material meeting the requirements of UL 94 V-0.

Applications

Typical applications include high speed applications requiring low losses at high frequencies and high dV/dt, such as electrical ballasts, televisions, video and telecommunications.

Benefits

- Rated voltage: 63 – 1,000 VDC
- Rated voltage: 40 – 250 VAC
- Capacitance range: 0.0001 – 0.022 μ F
- Lead spacing: 5 mm
- Capacitance tolerance: \pm 1%, \pm 2%, \pm 2.5%, \pm 5%, \pm 10%
- Climatic category: 55/100/56, IEC 60068-1
- Tape and reel packaging in accordance with IEC 60286-2
- RoHS Compliant and lead-free terminations
- Category temperature range of -55°C to +100°C

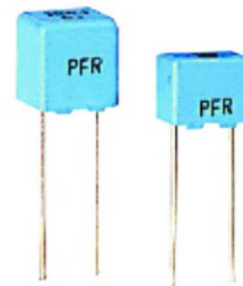

Legacy Part Number System

PFR	5	101	J	63	J11	L4	BULK
Series	Lead Spacing (mm)	Capacitance Code (pF)	Capacitance Tolerance	Rated Voltage (VDC)	Size Code	Lead Length	Packaging
Polypropylene Film/Foil	5 (Standard)	First two digits represent significant figures. Third digit specifies number of zeros.	F = \pm 1% G = \pm 2% H = \pm 2.5% J = \pm 5% K = \pm 10%	63 = 63 100 = 100 250 = 250 400 = 400 630 = 630 1000 = 1000	See Dimension Table	Letter "L" followed by lead length in mm	See Ordering Options Table

New KEMET Part Number System

F	411	J	H	101	J	063	C
Capacitor Class	Series	Lead Spacing (mm)	Size Code	Capacitance Code (pF)	Capacitance Tolerance	Rated Voltage (VDC)	Packaging
F = Film	Polypropylene Film/Foil	J = 5.0	See Dimension Table	First two digits represent significant figures. Third digit specifies number of zeros.	F = \pm 1% G = \pm 2% H = \pm 2.5% J = \pm 5% K = \pm 10%	063 = 63 100 = 100 250 = 250 400 = 400 630 = 630 1K0 = 1000	See Ordering Options Table

Ordering Options Table

Lead Spacing Nominal (mm)	Type of Leads and Packaging	Lead Length (mm)	KEMET Lead and Packaging Code	Legacy Lead and Packaging Code
5	Standard Lead and Packaging Options			
	Bulk (Bag) – Short Leads	4 +1/-0	C	Bulk
	Tape & Reel (Standard Reel)	H ₀ = 18.5 +/-0.5	L	TR18
	Other Lead and Packaging Options			
	Ammo Pack	H ₀ = 16.5 +/-0.5	Q	TA16
	Ammo Pack	H ₀ = 18.5 +/-0.5	R	TA18
Tape & Reel (Large Reel)	H ₀ = 18.5 +/-0.5	P	LR18	

Dimensions – Millimeters

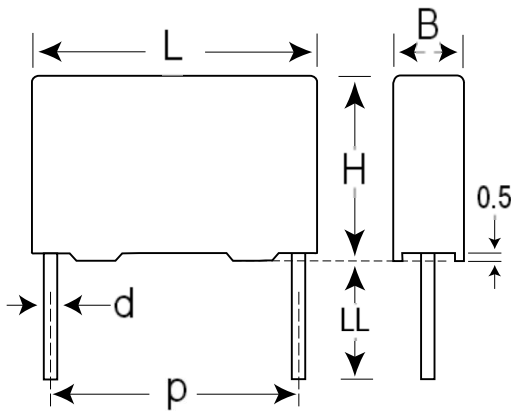

KEMET Size Code	Legacy Size Code	p		B		H		L		d	
		Nominal	Tolerance	Nominal	Tolerance	Nominal	Tolerance	Nominal	Tolerance	Nominal	Tolerance
JH	J11	5	-0.4	4.5	Maximum	6	Maximum	7.2	Maximum	0.5	+/-0.05
JK	J12	5	-0.4	5.5	Maximum	7	Maximum	7.2	Maximum	0.5	+/-0.05
JR	J13	5	-0.4	6.5	Maximum	8	Maximum	7.2	Maximum	0.5	+/-0.05

Note: See Ordering Options Table for lead length (LL) options.

Performance Characteristics

Voltage Range (VDC)	63	100	250	400	630	1000
Voltage Range (VAC)	40	63	160	220	250	250
Capacitance Range (μF)	0.0001 – 0.022	0.0001 – 0.01	0.0001 – 0.0068	0.0001 – 0.0068	0.0001 – 0.0047	0.0001 – 0.001
Capacitance Values	In accordance with IEC E12 series					
Capacitance Tolerance	$\pm 1\%$, $\pm 2\%$, $\pm 2.5\%$, $\pm 5\%$, $\pm 10\%$					
Category Temperature Range	-55°C to +100°C. An operating temperature up to +105°C is allowed under certain conditions. Please consult KEMET for details					
Climatic Category	IEC 60068-1, 55/100/56					
Capacitance Drift	Maximum 0.3% after a 2 year storage period at a temperature of +10°C to +40°C and a relative humidity of 40% to 60%					
Temperature Coefficient	-200 (+50, -100) ppm/°C at 1 kHz					
Self-Inductance	Approximately 6 nH/cm for the total length of capacitor winding and the leads					
Dissipation Factor $\tan\delta$	Maximum Values at +23°C					
		$C \leq 0.001 \mu\text{F}$	$0.001 \mu\text{F} < C \leq 0.0047 \mu\text{F}$		$C > 0.0047 \mu\text{F}$	
	1 kHz	0.0004	0.0004		0.0004	
	10 kHz	0.0004	0.0005		0.0007	
	100 kHz	0.0005	0.0007		–	
Insulation Resistance	Measured at +20°C, according to IEC 60384-13					
	Minimum value between terminals 100,000 M Ω					

Resonance Frequencies

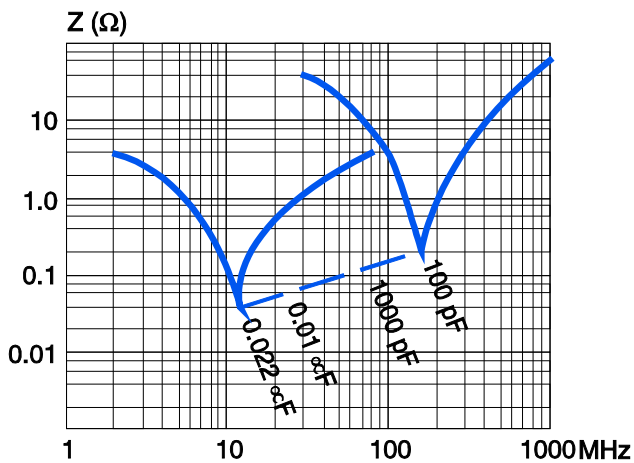

Environmental Test Data

Test	IEC Publication	Procedure	Requirements
Voltage Proof	60384-1 Clause 4.6	$1.6 \times V_R$ after 60 seconds	The capacitors must withstand the voltage without breakdowns or flashovers and without decreased insulation resistance below the value in each detail specification. No visible damage
	Clause 4.6 2.3	$2 \times V_R$ (minimum 400 VDC to case) after 60 seconds	As above
Vibration	60068-2-6 Test Fc	6 hours with 10 – 500 Hz and 0.75 mm amplitude or 98 m/s ² depending on frequency	No visible damage $\tan\delta \leq 1.2 \times$ stated value at 100 kHz $\Delta C/C \leq \pm 0.5\%$
Bump	60068-2-29 Test Eb	4,000 bumps with 390 m/s ² mounted on PCB	$\Delta C/C \leq \pm 0.5\%$ $\tan\delta \leq 1.2 \times$ stated value at 100 kHz Insulation resistance: $\geq 100,000 \text{ M}\Omega$ for $C_R \leq 0.33 \mu\text{F}$ $\geq 30,000 \text{ M}\Omega \cdot \mu\text{F}$ for $C_R > 0.33 \mu\text{F}$
Resistance to Soldering Heat	60068-2-20 Method 1A	Solder bath at + 260°C \pm 5°C with screening	Immersion of the terminations into the solder bath shall be completed in a time not exceeding 1 second and the terminations shall remain immersed to the specified depth for 10 + 1 second and then be withdrawn. $\Delta C/C \leq \pm 0.5\%$ $\tan\delta$ increase < 0.001 No visible damage
Climatic Sequence	60384-1 Paragraph 4:21	60068-2.2 dry heat 16 hours 60068-2-34 damp heat, one cycle 60068-2-1 Test Aa 2 hours	Insulation resistance: $\geq 100,000 \text{ M}\Omega$ for $C_R \leq 0.33 \mu\text{F}$ $\geq 30,000 \text{ M}\Omega \cdot \mu\text{F}$ for $C_R > 0.33 \mu\text{F}$ $\Delta C/C \leq \pm 0.5\%$ $\tan\delta \leq 1.2 \times$ stated value at 100 kHz
Damp Heat Steady State	60068-2-3 Test Ca	+40°C and 90 – 95% RH	56 days no visible damage Insulation resistance: $\geq 50,000 \text{ M}\Omega$ for $C_R \leq 0.33 \mu\text{F}$ $\geq 15,000 \text{ M}\Omega \cdot \mu\text{F}$ for $C_R > 0.33 \mu\text{F}$ $\Delta C/C \leq \pm 1\%$ $\tan\delta \leq 1.2 \times$ stated value at 100 kHz
Endurance, AC		1,000 hours at +85°C and $1.25 \times V_R$ AC	No visible damage $\Delta C/C \leq \pm 3\%$ $\tan\delta \leq 1.5 \times$ stated value at 100 kHz Insulation resistance: $\geq 100,000 \text{ M}\Omega$ for $C_R \leq 0.33 \mu\text{F}$ $\geq 30,000 \text{ M}\Omega \cdot \mu\text{F}$ for $C_R > 0.33 \mu\text{F}$
Charge and Discharge	60384-17 Paragraph 4.13	10,000 pulses and with (2 x) dV/dt according to detail specification	$\tan\delta$ (100 kHz) $\leq 2 \times$ stated value (100 kHz) $\Delta C/C \leq \pm 0.5\%$ Insulation resistance: $\geq 50,000 \text{ M}\Omega$ for $C_R \leq 0.33 \mu\text{F}$ $\geq 15,000 \text{ M}\Omega \cdot \mu\text{F}$ for $C_R > 0.33 \mu\text{F}$

Environmental Compliance

All KEMET pulse capacitors are RoHS Compliant.

Table 1 – Ratings & Part Number Reference

VDC	VAC	Cap Value (µF)	Max Dimensions in mm			Lead Spacing (p)	dV/dt (V/µs)	Size Code (New/Legacy)	New KEMET Part Number	Legacy Part Number
			B	H	L					
63	40	0.00010	4.5	6.0	7.2	5	1000	JH/J11	F411JH101(1)063(2)	PFR5101(1)63J11L4(2)
63	40	0.00015	4.5	6.0	7.2	5	1000	JH/J11	F411JH151(1)063(2)	PFR5151(1)63J11L4(2)
63	40	0.00022	4.5	6.0	7.2	5	1000	JH/J11	F411JH221(1)063(2)	PFR5221(1)63J11L4(2)
63	40	0.00033	4.5	6.0	7.2	5	1000	JH/J11	F411JH331(1)063(2)	PFR5331(1)63J11L4(2)
63	40	0.00047	4.5	6.0	7.2	5	1000	JH/J11	F411JH471(1)063(2)	PFR5471(1)63J11L4(2)
63	40	0.00068	4.5	6.0	7.2	5	1000	JH/J11	F411JH681(1)063(2)	PFR5681(1)63J11L4(2)
63	40	0.0010	4.5	6.0	7.2	5	1000	JH/J11	F411JH102(1)063(2)	PFR5102(1)63J11L4(2)
63	40	0.0015	4.5	6.0	7.2	5	1000	JH/J11	F411JH152(1)063(2)	PFR5152(1)63J11L4(2)
63	40	0.0022	4.5	6.0	7.2	5	1000	JH/J11	F411JH222(1)063(2)	PFR5222(1)63J11L4(2)
63	40	0.0033	4.5	6.0	7.2	5	1000	JH/J11	F411JH332(1)063(2)	PFR5332(1)63J11L4(2)
63	40	0.0047	4.5	6.0	7.2	5	1000	JH/J11	F411JH472(1)063(2)	PFR5472(1)63J11L4(2)
63	40	0.0068	4.5	6.0	7.2	5	1000	JH/J11	F411JH682(1)063(2)	PFR5682(1)63J11L4(2)
63	40	0.010	5.5	7.0	7.2	5	1000	JK/J12	F411JK103(1)063(2)	PFR5103(1)63J12L4(2)
63	40	0.015	6.5	8.0	7.2	5	1000	JR/J13	F411JR153(1)063(2)	PFR5153(1)63J13L4(2)
63	40	0.020	6.5	8.0	7.2	5	1000	JR/J13	F411JR203(1)063(2)	PFR5203(1)63J13L4(2)
63	40	0.022	6.5	8.0	7.2	5	1000	JR/J13	F411JR223(1)063(2)	PFR5223(1)63J13L4(2)
100	63	0.00010	4.5	6.0	7.2	5	1000	JH/J11	F411JH101(1)100(2)	PFR5101(1)100J11L4(2)
100	63	0.00015	4.5	6.0	7.2	5	1000	JH/J11	F411JH151(1)100(2)	PFR5151(1)100J11L4(2)
100	63	0.00022	4.5	6.0	7.2	5	1000	JH/J11	F411JH221(1)100(2)	PFR5221(1)100J11L4(2)
100	63	0.00033	4.5	6.0	7.2	5	1000	JH/J11	F411JH331(1)100(2)	PFR5331(1)100J11L4(2)
100	63	0.00047	4.5	6.0	7.2	5	1000	JH/J11	F411JH471(1)100(2)	PFR5471(1)100J11L4(2)
100	63	0.00068	4.5	6.0	7.2	5	1000	JH/J11	F411JH681(1)100(2)	PFR5681(1)100J11L4(2)
100	63	0.0010	4.5	6.0	7.2	5	1000	JH/J11	F411JH102(1)100(2)	PFR5102(1)100J11L4(2)
100	63	0.0015	4.5	6.0	7.2	5	1000	JH/J11	F411JH152(1)100(2)	PFR5152(1)100J11L4(2)
100	63	0.0022	4.5	6.0	7.2	5	1000	JH/J11	F411JH222(1)100(2)	PFR5222(1)100J11L4(2)
100	63	0.0033	5.5	7.0	7.2	5	1000	JK/J12	F411JK332(1)100(2)	PFR5332(1)100J12L4(2)
100	63	0.0047	5.5	7.0	7.2	5	1000	JK/J12	F411JK472(1)100(2)	PFR5472(1)100J12L4(2)
100	63	0.0068	6.5	8.0	7.2	5	1000	JR/J13	F411JR682(1)100(2)	PFR5682(1)100J13L4(2)
100	63	0.010	6.5	8.0	7.2	5	1000	JR/J13	F411JR103(1)100(2)	PFR5103(1)100J13L4(2)
250	160	0.00010	4.5	6.0	7.2	5	1000	JH/J11	F411JH101(1)250(2)	PFR5101(1)250J11L4(2)
250	160	0.00015	4.5	6.0	7.2	5	1000	JH/J11	F411JH151(1)250(2)	PFR5151(1)250J11L4(2)
250	160	0.00022	4.5	6.0	7.2	5	1000	JH/J11	F411JH221(1)250(2)	PFR5221(1)250J11L4(2)
250	160	0.00033	4.5	6.0	7.2	5	1000	JH/J11	F411JH331(1)250(2)	PFR5331(1)250J11L4(2)
250	160	0.00047	4.5	6.0	7.2	5	1000	JH/J11	F411JH471(1)250(2)	PFR5471(1)250J11L4(2)
250	160	0.00068	4.5	6.0	7.2	5	1000	JH/J11	F411JH681(1)250(2)	PFR5681(1)250J11L4(2)
250	160	0.0010	4.5	6.0	7.2	5	1000	JH/J11	F411JH102(1)250(2)	PFR5102(1)250J11L4(2)
250	160	0.0015	4.5	6.0	7.2	5	1000	JH/J11	F411JH152(1)250(2)	PFR5152(1)250J11L4(2)
250	160	0.0022	4.5	6.0	7.2	5	1000	JH/J11	F411JH222(1)250(2)	PFR5222(1)250J11L4(2)
250	160	0.0033	5.5	7.0	7.2	5	1000	JK/J12	F411JK332(1)250(2)	PFR5332(1)250J12L4(2)
250	160	0.0047	6.5	8.0	7.2	5	1000	JR/J13	F411JR472(1)250(2)	PFR5472(1)250J13L4(2)
250	160	0.0068	6.5	8.0	7.2	5	1000	JR/J13	F411JR682(1)250(2)	PFR5682(1)250J13L4(2)
400	220	0.00010	4.5	6.0	7.2	5	1000	JH/J11	F411JH101(1)400(2)	PFR5101(1)400J11L4(2)
400	220	0.00015	4.5	6.0	7.2	5	1000	JH/J11	F411JH151(1)400(2)	PFR5151(1)400J11L4(2)
400	220	0.00022	4.5	6.0	7.2	5	1000	JH/J11	F411JH221(1)400(2)	PFR5221(1)400J11L4(2)
400	220	0.00033	4.5	6.0	7.2	5	1000	JH/J11	F411JH331(1)400(2)	PFR5331(1)400J11L4(2)
400	220	0.00047	4.5	6.0	7.2	5	1000	JH/J11	F411JH471(1)400(2)	PFR5471(1)400J11L4(2)
400	220	0.00068	4.5	6.0	7.2	5	1000	JH/J11	F411JH681(1)400(2)	PFR5681(1)400J11L4(2)
400	220	0.0010	4.5	6.0	7.2	5	1000	JH/J11	F411JH102(1)400(2)	PFR5102(1)400J11L4(2)
400	220	0.0015	4.5	6.0	7.2	5	1000	JH/J11	F411JH152(1)400(2)	PFR5152(1)400J11L4(2)
400	220	0.0022	4.5	6.0	7.2	5	1000	JH/J11	F411JH222(1)400(2)	PFR5222(1)400J11L4(2)
400	220	0.0033	5.5	7.0	7.2	5	1000	JK/J12	F411JK332(1)400(2)	PFR5332(1)400J12L4(2)
400	220	0.0047	6.5	8.0	7.2	5	1000	JR/J13	F411JR472(1)400(2)	PFR5472(1)400J13L4(2)
400	220	0.0068	6.5	8.0	7.2	5	1000	JR/J13	F411JR682(1)400(2)	PFR5682(1)400J13L4(2)
630	250	0.00010	4.5	6.0	7.2	5	1000	JH/J11	F411JH101(1)630(2)	PFR5101(1)630J11L4(2)
630	250	0.00015	4.5	6.0	7.2	5	1000	JH/J11	F411JH151(1)630(2)	PFR5151(1)630J11L4(2)
630	250	0.00022	4.5	6.0	7.2	5	1000	JH/J11	F411JH221(1)630(2)	PFR5221(1)630J11L4(2)
630	250	0.00033	4.5	6.0	7.2	5	1000	JH/J11	F411JH331(1)630(2)	PFR5331(1)630J11L4(2)
630	250	0.00047	4.5	6.0	7.2	5	1000	JH/J11	F411JH471(1)630(2)	PFR5471(1)630J11L4(2)
630	250	0.00068	4.5	6.0	7.2	5	1000	JH/J11	F411JH681(1)630(2)	PFR5681(1)630J11L4(2)
630	250	0.0010	4.5	6.0	7.2	5	1000	JH/J11	F411JH102(1)630(2)	PFR5102(1)630J11L4(2)

(1) F = ±1%, G = ±2%, H = ±2.5%, J = ±5%, K = ±10%.

(2) Insert lead and packaging code. See Ordering Options Table for available options.

Table 1 – Ratings & Part Number Reference cont'd

VDC	VAC	Cap Value (µF)	Max Dimensions in mm			Lead Spacing (p)	dV/dt (V/µs)	Size Code (New/Legacy)	New KEMET Part Number	Legacy Part Number
			B	H	L					
630	250	0.0015	4.5	6.0	7.2	5	1000	JH/J11	F411JH152(1)630(2)	PFR5152(1)630J11L4(2)
630	250	0.0022	5.5	7.0	7.2	5	1000	JK/J12	F411JK222(1)630(2)	PFR5222(1)630J12L4(2)
630	250	0.0033	6.5	8.0	7.2	5	1000	JR/J13	F411JR332(1)630(2)	PFR5332(1)630J13L4(2)
630	250	0.0047	6.5	8.0	7.2	5	1000	JR/J13	F411JR472(1)630(2)	PFR5472(1)630J13L4(2)
1000	250	0.00010	4.5	6.0	7.2	5	1000	JH/J11	F411JH101(1)1K0(2)	PFR5101(1)1000J11L4(2)
1000	250	0.00015	4.5	6.0	7.2	5	1000	JH/J11	F411JH151(1)1K0(2)	PFR5151(1)1000J11L4(2)
1000	250	0.00022	4.5	6.0	7.2	5	1000	JH/J11	F411JH221(1)1K0(2)	PFR5221(1)1000J11L4(2)
1000	250	0.00033	5.5	7.0	7.2	5	1000	JK/J12	F411JK331(1)1K0(2)	PFR5331(1)1000J12L4(2)
1000	250	0.00047	5.5	7.0	7.2	5	1000	JK/J12	F411JK471(1)1K0(2)	PFR5471(1)1000J12L4(2)
1000	250	0.00068	5.5	7.0	7.2	5	1000	JK/J12	F411JK681(1)1K0(2)	PFR5681(1)1000J12L4(2)
1000	250	0.0010	6.5	8.0	7.2	5	1000	JR/J13	F411JR102(1)1K0(2)	PFR5102(1)1000J13L4(2)
VDC	VAC	Cap Value (µF)	B (mm)	H (mm)	L (mm)	Lead Spacing (p)	dV/dt (V/µs)	Size Code (New/Legacy)	New KEMET Part Number	Legacy Part Number

(1) F = ±1%, G = ±2%, H = ±2.5%, J = ±5%, K = ±10%.

(2) Insert lead and packaging code. See Ordering Options Table for available options.

Soldering Process

The implementation of the RoHS directive has resulted in the selection of SnAgCu (SAC) alloys or SnCu alloys as primary solder. This has increased the liquidus temperature from that of 183°C for SnPb eutectic alloy to 217 – 221°C for the new alloys. As a result, the heat stress to the components, even in wave soldering, has increased considerably due to higher pre-heat and wave temperatures. Polypropylene capacitors are especially sensitive to heat (the melting point of polypropylene is 160 – 170°C). Wave soldering can be destructive, especially for mechanically small polypropylene capacitors (with lead spacing of 5 mm to 15 mm), and great care has to be taken during soldering. The recommended solder profiles from KEMET should be used. Please consult KEMET with any questions. In general, the wave soldering curve from IEC Publication 61760-1 Edition 2 serves as a solid guideline for successful soldering. Please see Figure 1.

Reflow soldering is not recommended for through-hole film capacitors. Exposing capacitors to a soldering profile in excess of the above the recommended limits may result to degradation or permanent damage to the capacitors.

Do not place the polypropylene capacitor through an adhesive curing oven to cure resin for surface mount components. Insert through-hole parts after the curing of surface mount parts. Consult KEMET to discuss the actual temperature profile in the oven, if through-hole components must pass through the adhesive curing process. A maximum two soldering cycles is recommended. Please allow time for the capacitor surface temperature to return to a normal temperature before the second soldering cycle.

Manual Soldering Recommendations

Following is the recommendation for manual soldering with a soldering iron.

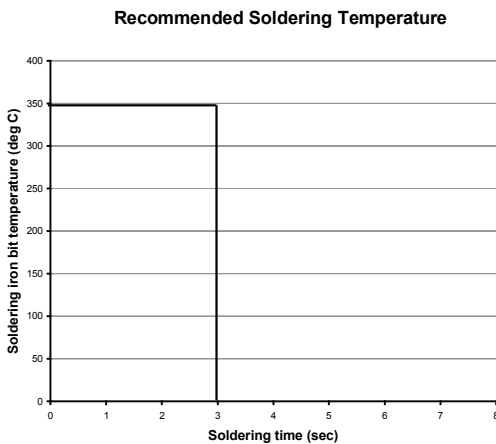

The soldering iron tip temperature should be set at 350°C (+10°C maximum) with the soldering duration not to exceed more than 3 seconds.

Wave Soldering Recommendations

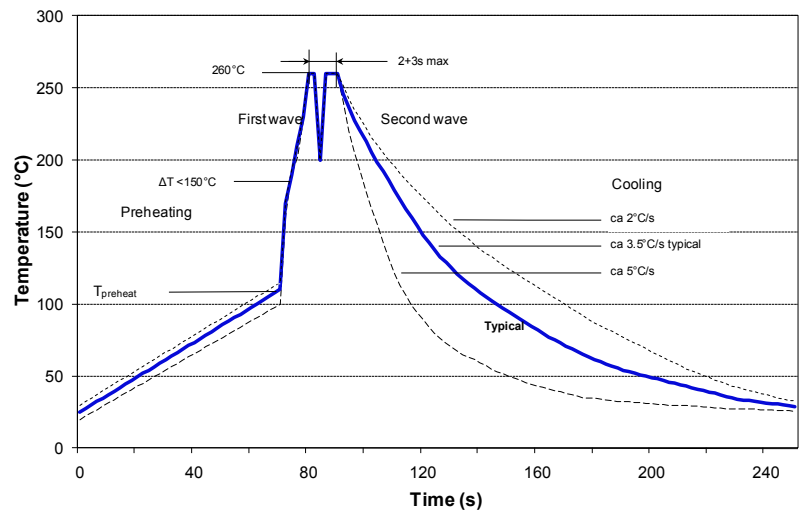

Soldering Process cont'd

Wave Soldering Recommendations cont'd

1. The table indicates the maximum set-up temperature of the soldering process

Figure 1

Dielectric Film Material	Maximum Preheat Temperature			Maximum Peak Soldering Temperature	
	Capacitor Pitch ≤ 10 mm	Capacitor Pitch = 15 mm	Capacitor Pitch > 15 mm	Capacitor Pitch ≤ 15 mm	Capacitor Pitch > 15 mm
Polyester	130°C	130°C	130°C	270°C	270°C
Polypropylene	100°C	110°C	130°C	260°C	270°C
Paper	130°C	130°C	140°C	270°C	270°C
Polyphenylene Sulphide	150°C	150°C	160°C	270°C	270°C

2. The maximum temperature measured inside the capacitor:

Set the temperature so that inside the element the maximum temperature is below the limit:

Dielectric Film Material	Maximum temperature measured inside the element
Polyester	160°C
Polypropylene	110°C
Paper	160°C
Polyphenylene sulphide	160°C

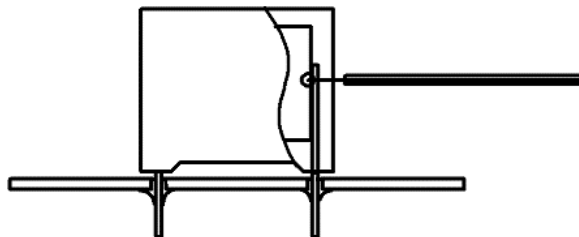

Temperature monitored inside the capacitor.

Selective Soldering Recommendations

Selective dip soldering is a variation of reflow soldering. In this method, the printed circuit board with through-hole components to be soldered is preheated and transported over the solder bath as in normal flow soldering without touching the solder. When the board is over the bath, it is stopped and pre-designed solder pots are lifted from the bath with molten solder only at the places of the selected components, and pressed against the lower surface of the board to solder the components.

The temperature profile for selective soldering is similar to the double wave flow soldering outlined in this document, **however, instead of two baths, there is only one bath with a time from 3 to 10 seconds.** In selective soldering, the risk of overheating is greater than in double wave flow soldering, and great care must be taken so that the parts are not overheated.

Marking

- Series
- Capacitance
- Capacitance tolerance
- Rated DC voltage

Packaging Quantities

KEMET Size Code	Legacy Size Code	Lead Spacing	Thickness (mm)	Height (mm)	Length (mm)	Bulk Short Leads	Bulk Long Leads	Standard Reel ø 360 mm	Large Reel ø 500 mm	Ammo
JF	J01	5	2.5	6.5	7.2	2000	2000	2500	5000	3000
JJ	J02		3.5	8	7.2	2000	2000	2000	4000	2000
JL	J03		4.5	9	7.2	1000	1000	1500	3000	1700
JQ	J04		5	10	7.2	1000	1000	1300	2600	1500
JT	J05		6	11	7.2	1000	1000	1000	2000	1200
JU	J06		7.2	13	7.2	1000	1000	800	1600	–
JH	J11		4.5	6	7.2	1000	1000	1500	3000	1700
JK	J12		5.5	7	7.2	1000	1000	1200	2400	1300
JR	J13		6.5	8	7.2	1000	1000	900	1800	1100

Lead Taping & Packaging (IEC 60286–2)

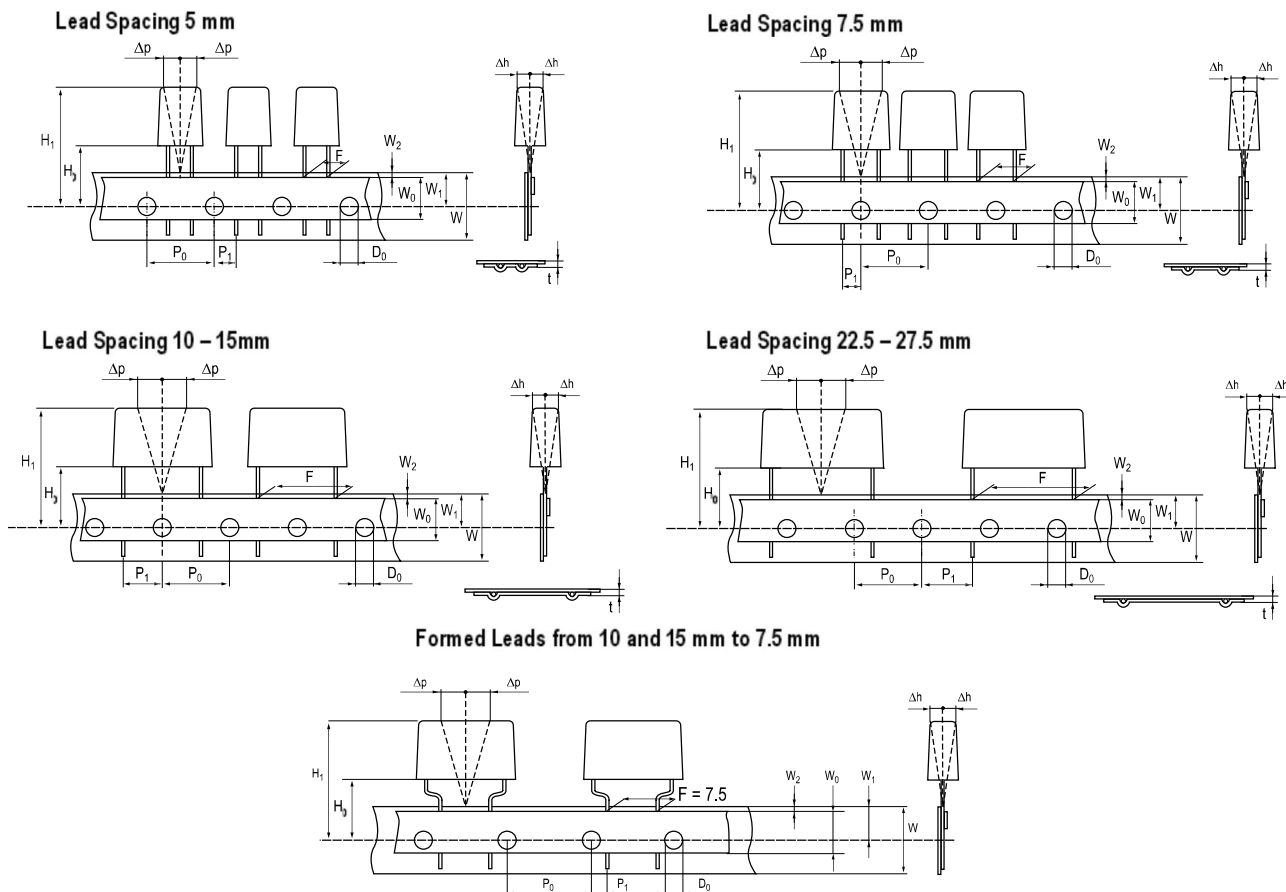

Taping Specification

Dimensions in mm										Standard IEC 60286–2
Lead spacing	+6/-0.1	F	5	7.5	Formed 7.5	10	15	22.5	27.5	F
Carrier tape width	+/-0.5	W	18	18	18	18	18	18	18	18 ^{+1/-0.5}
Hold-down tape width	+/-0.3	W_0	9	9	9	12	12	12	12	
Position of sprocket hole	+/-0.5	W_1	9	9	9	9	9	9	9	9 ^{+0.75/-0.5}
Distance between tapes	Maximum	W_2	3	3	3	3	3	3	3	3
Sprocket hole diameter	+/-0.2	D_0	4	4	4	4	4	4	4	4
Feed hole lead spacing	+/-0.3	$P_0^{(1)}$	12.7	12.7	12.7 ⁽⁴⁾	12.7	12.7	12.7	12.7	12.7
Distance lead – feed hole	+/-0.7	P_1	3.85	3.75	3.75	7.7	5.2	5.3	5.3	P ¹
Deviation tape – plane	Maximum	Δp	1.3	1.3	1.3	1.3	1.3	1.3	1.3	1.3
Lateral deviation	Maximum	Δh	2	2	2	2	2	2	2	2
Total thickness	+/-0.2	t	0.7	0.7	0.7	0.7	0.7	0.9 ^{MAX}	0.9 ^{MAX}	0.9 ^{MAX}
Sprocket hole/cap body	Nominal	$H_0^{(2)}$	18.5 ^{+/-0.5}	18.5 ^{+/-0.5}	18.5 ^{+/-0.5}	18.5 ^{+/-0.5}	18.5 ^{+/-0.5}	18.5 ^{+/-0.5}	18.5 ^{+/-0.5}	18 ^{+2/-0}
Sprocket hole/top of cap body	Maximum	$H_1^{(3)}$	32	31	43	43	43	58	58	58 ^{MAX}

(1) Maximum cumulative feed hole error, 1 mm per 20 parts.

(2) 16.5 mm available on request.

(3) Depending on case size.

(4) 15 mm available on request.

Lead Taping & Packaging (IEC 60286–2) cont'd

Ammo Specifications

Series	Dimensions (mm)		
	H	W	T
R4x, R4x+R, R7x, RSB	360	340	59
F5A, F5B, F5D			
F6xx, F8xx			
PHExxx, PMExxx, PMRxxx, SMR & PFR	330	330	50

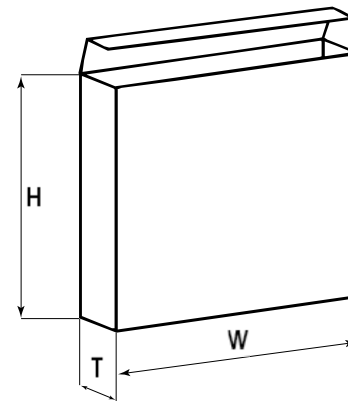

Reel Specifications

Series	Dimensions (mm)		
	D	H	W
R4x, R4x+R, R7x, RSB	355 500	30 25	55 (Max)
F5A, F5B, F5D			
F6xx, F8xx			
PHExxx, PMExxx, PMRxxx, SMR & PFR	360 500	30	46 (Max)

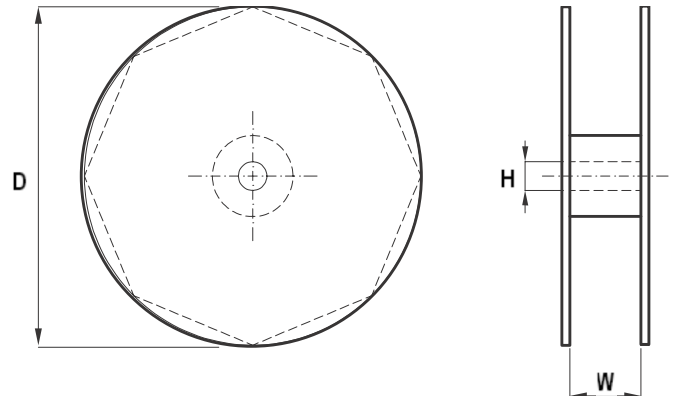

Manufacturing Date Code (IEC–60062)

Y = Year, Z = Month			
Year	Code	Month	Code
2000	M	January	1
2001	N	February	2
2002	P	March	3
2003	R	April	4
2004	S	May	5
2005	T	June	6
2006	U	July	7
2007	V	August	8
2008	W	September	9
2009	X	October	O
2010	A	November	N
2011	B	December	D
2012	C		
2013	D		
2014	E		
2015	F		
2016	H		
2017	J		
2018	K		
2019	L		
2020	M		

KEMET Corporation World Headquarters

2835 KEMET Way
Simpsonville, SC 29681

Mailing Address:
P.O. Box 5928
Greenville, SC 29606

www.kemet.com
Tel: 864-963-6300
Fax: 864-963-6521

Corporate Offices
Fort Lauderdale, FL
Tel: 954-766-2800

North America

Southeast

Lake Mary, FL
Tel: 407-855-8886

Northeast

Wilmington, MA
Tel: 978-658-1663

Central

Novi, MI
Tel: 248-306-9353

West

Milpitas, CA
Tel: 408-433-9950

Mexico

Guadalajara, Jalisco
Tel: 52-33-3123-2141

Europe

Southern Europe

Sasso Marconi, Italy
Tel: 39-051-939111

Skopje, Macedonia
Tel: 389-2-55-14-623

Central Europe

Landsberg, Germany
Tel: 49-8191-3350800

Kamen, Germany
Tel: 49-2307-438110

Northern Europe

Harlow, United Kingdom
Tel: 44-1279-460122

Espoo, Finland
Tel: 358-9-5406-5000

Asia

Northeast Asia

Hong Kong
Tel: 852-2305-1168

Shenzhen, China
Tel: 86-755-2518-1306

Beijing, China
Tel: 86-10-5877-1075

Shanghai, China
Tel: 86-21-6447-0707

Seoul, South Korea
Tel: 82-2-6294-0550

Taipei, Taiwan
Tel: 886-2-27528585

Southeast Asia

Singapore
Tel: 65-6701-8033

Penang, Malaysia
Tel: 60-4-6430200

Bangalore, India
Tel: 91-806-53-76817

Note: KEMET reserves the right to modify minor details of internal and external construction at any time in the interest of product improvement. KEMET does not assume any responsibility for infringement that might result from the use of KEMET Capacitors in potential circuit designs. KEMET is a registered trademark of KEMET Electronics Corporation.

Disclaimer

All product specifications, statements, information and data (collectively, the "Information") in this datasheet are subject to change. The customer is responsible for checking and verifying the extent to which the Information contained in this publication is applicable to an order at the time the order is placed.

All Information given herein is believed to be accurate and reliable, but it is presented without guarantee, warranty, or responsibility of any kind, expressed or implied.

Statements of suitability for certain applications are based on KEMET Electronics Corporation's ("KEMET") knowledge of typical operating conditions for such applications, but are not intended to constitute – and KEMET specifically disclaims – any warranty concerning suitability for a specific customer application or use. The Information is intended for use only by customers who have the requisite experience and capability to determine the correct products for their application. Any technical advice inferred from this Information or otherwise provided by KEMET with reference to the use of KEMET's products is given gratis, and KEMET assumes no obligation or liability for the advice given or results obtained.

Although KEMET designs and manufactures its products to the most stringent quality and safety standards, given the current state of the art, isolated component failures may still occur. Accordingly, customer applications which require a high degree of reliability or safety should employ suitable designs or other safeguards (such as installation of protective circuitry or redundancies) in order to ensure that the failure of an electrical component does not result in a risk of personal injury or property damage.

Although all product-related warnings, cautions and notes must be observed, the customer should not assume that all safety measures are indicated or that other measures may not be required.