

**STEP 1**  
STRIP CABLE AS SHOWN.  
FEED THE END OF THE CABLE THROUGH THE BOOT, CABLE CLAMP HOUSING, AND COUPLING RING IN THE ORDER AND POSITION SHOWN. CRIMP CONDUCTOR TO CONTACT. CONTACT #1 TO BE NEXT TO NOTCH.

\*\*\*REMAINING CONTACTS TO BE PLACED COUNTER CLOCKWISE.

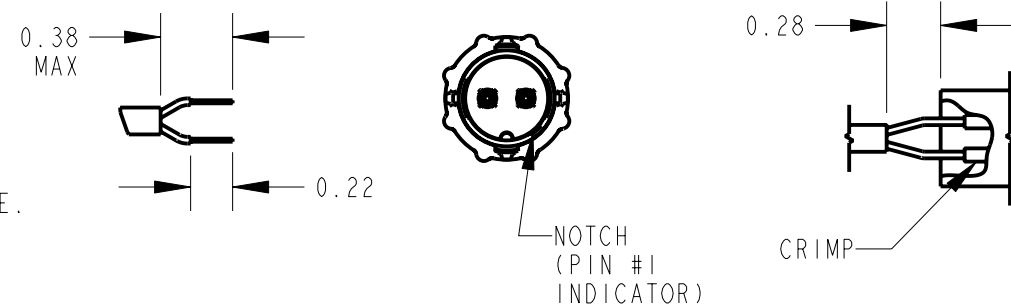

### SPECIFICATIONS

**MECHANICAL:**  
SHOCK: MIL-STD 202 METHOD 213B, COND. K.  
VIBRATION: MIL-STD 202 METHOD 201  
LIFE: 300 INSERTION/WITHDRAWAL CYCLES (MINIMUM)

**ELECTRICAL**  
DIELECTRIC WITHSTANDING VOLTAGE: 1,000 VAC  
INSULATION RESISTANCE: 100 MEGOHMS (MIN) AT 77°F  
CONTACT RESISTANCE: 5.0 MILLOHMS MAX.  
CURRENT RATING: 7.5 AMPS (#20 CONTACT)  
6.5 AMPS (7 & 8 PIN #20 CONTACT)  
13.0 AMPS (#16 CONTACT)

**ENVIRONMENTAL**  
TEMPERATURE LIMITS: -40°C TO +65°C (NON-OPERATING)  
MOISTURE RESISTANCE: MIL-STD 202 METHOD 106F  
INSULATION RESISTANCE: MIL-STD 202 METHOD 302, COND. B  
THERMAL SHOCK: MIL-STD 202 METHOD 107G  
SALT SPRAY: MIL-STD 202 METHOD 101D, COND. B  
WATER TIGHTNESS TEST: U.S. COAST GUARD CFR 46 PART 110.20

**STEP 2**  
ALIGN COUPLING RING'S TABS WITH CORD CONNECTOR'S SIDE NOTCHES AND PUSH THE COUPLING RING ONTO CORD CONNECTOR.

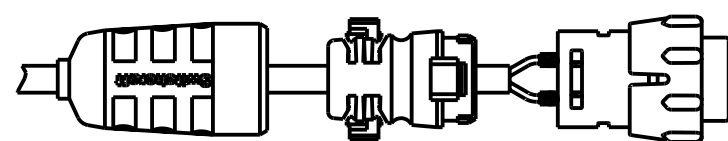

**STEP 3**  
PUSH THE CABLE CLAMP HOUSING FORWARD UNTIL IT LOCKS INTO THE CONNECTOR BODY AND SNAP THE TWO CLAMPS INTO ITS COMPARTMENTS.

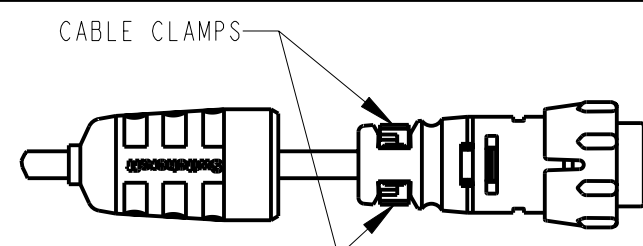

**STEP 4**  
PUSH THE BOOT ALL THE WAY FORWARD TO SEAT TIGHTLY ONTO THE CABLE CLAMP HOUSING.

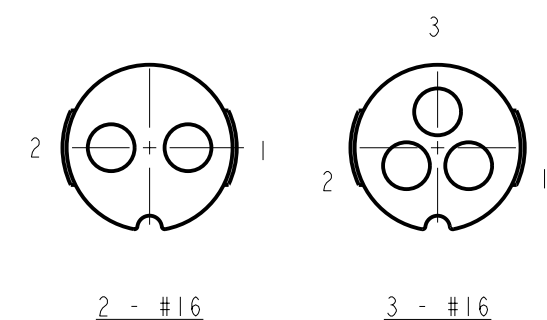
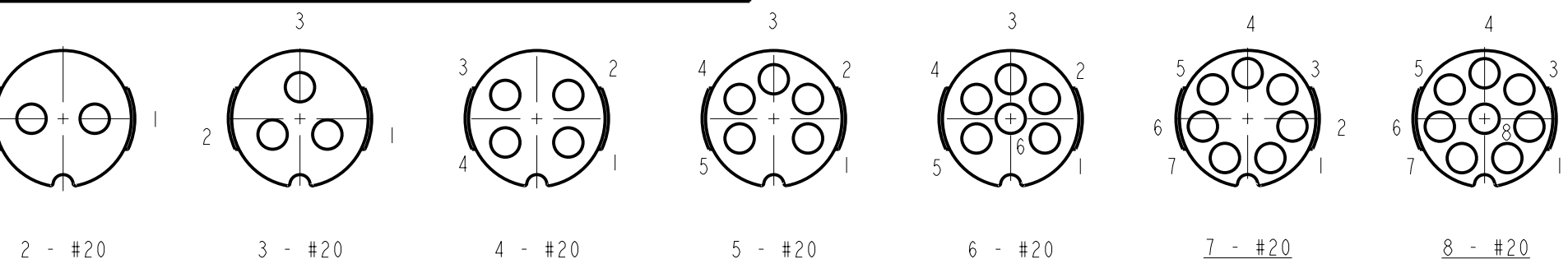
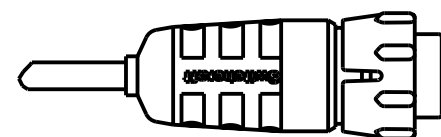

### CONTACT ARRANGEMENTS

SHOWN ARE REAR VIEWS OF FEMALE CORD CONNECTORS

**MATERIALS:**  
CORD CONNECTOR SHELL, CONTACT LOCKING DISK, COUPLING RING AND CABLE CLAMP ASSEMBLY:  
THERMOPLASTIC POLYMER GLASS FIBER, FLAME RETARDANT  
REAR BOOT AND CONNECTOR SHELL INTERIOR:  
THERMOPLASTIC RUBBER  
CONTACTS: COPPER BASE ALLOY GOLD-PLATED OVER NICKEL UNDERPLATE

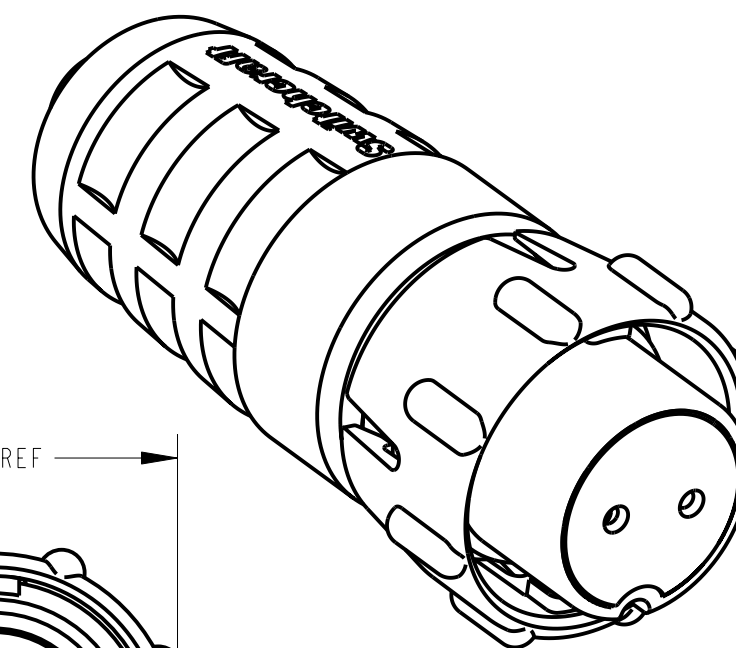
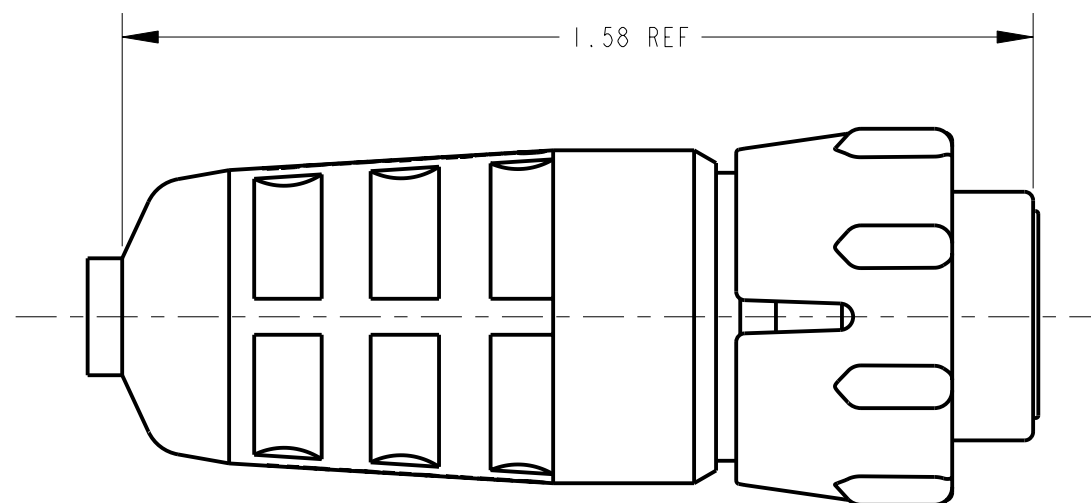
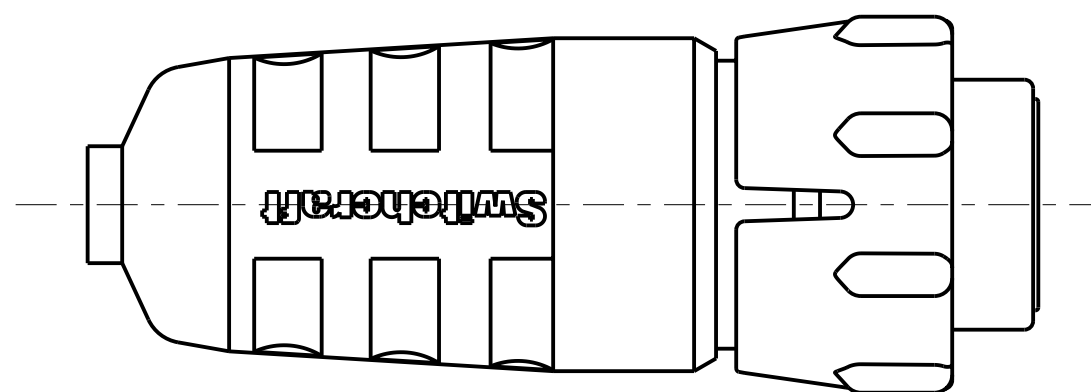

CUSTOMER DRAWING

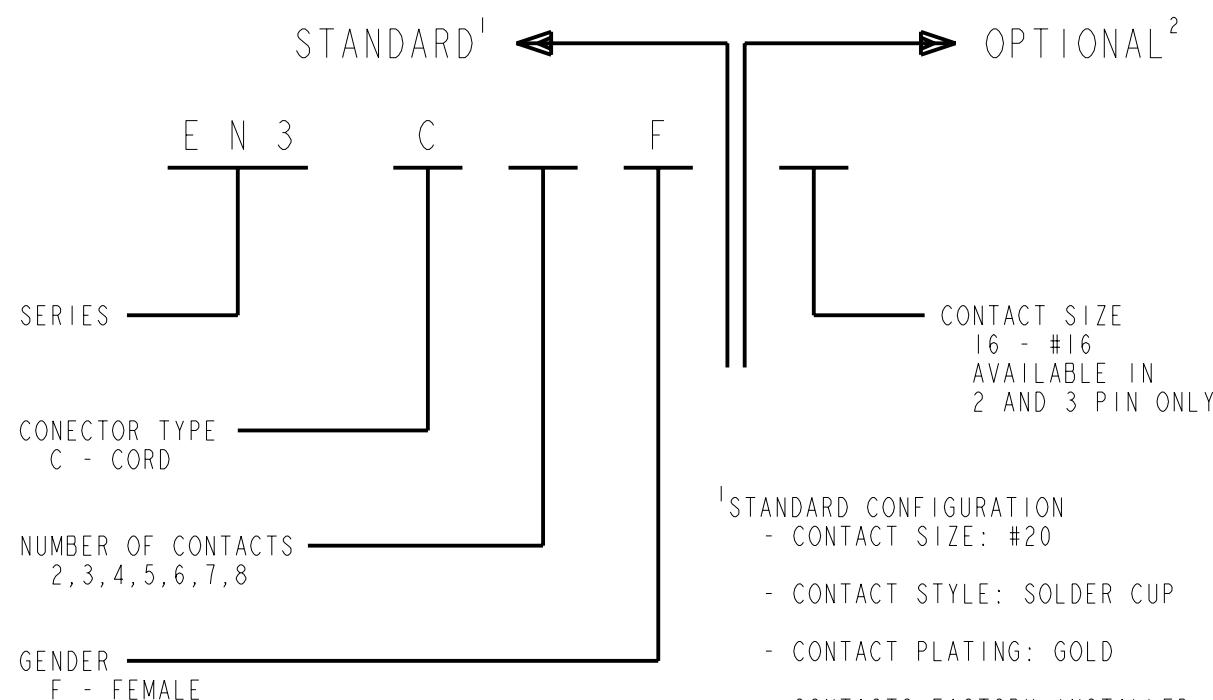

<sup>1</sup>STANDARD CONFIGURATION  
- CONTACT SIZE: #20  
- CONTACT STYLE: SOLDER CUP  
- CONTACT PLATING: GOLD  
- CONTACTS FACTORY INSTALLED  
- PACKAGED IN BULK

<sup>2</sup>OPTIONAL CONFIGURATION  
- LEAVE BLANK FOR STANDARD CONFIGURATION

REV	ECO NUMBER	DATE	BY	APVD
G	22232	6-7-98	SG	RB
F	21282	2-5-97	SG	RB
E	20897	2-5-97	SG	RB
REVISIONS				

★ STAR SYMBOL DENOTES CRITICAL DIMENSION  
UNLESS OTHERWISE SPECIFIED  
1. ALL DIMENSIONS IN INCHES  
- TWO PLACE DECIMALS ±0.01  
- THREE PLACE DECIMALS ±0.005  
- ANGLES ±1°  
- ALL DIA. CONCENTRIC WITHIN 0.005 T.I.R.  
2. FEATURES ON THE SAME CENTERLINE MUST BE ALIGNED WITHIN ±0.002  
3. REMOVE ALL BURRS

THIS DRAWING DESCRIBES A DESIGN CONSIDERED PROPRIETARY IN NATURE, DEVELOPED AND MANUFACTURED BY SWITCHCRAFT INC. AND IS RELEASED ON A CONFIDENTIAL BASIS FOR IDENTIFICATION PURPOSES ONLY.				
SIZE	WIDTH	MULT	LBS/M	TEMPER
FINISH		MATERIAL		
SPEC No.		SPEC No.		
FIRST USED ON		SCALE		
DATE DRAWN		BY	CHKD	APVD
3-4-94		SG	2-6-95	2-6-95
NAME		PART No.		
FEMALE CORD CONNECTOR		EN3C_F		
DO NOT SCALE DRAWING				REV
G				G

# Mouser Electronics

Authorized Distributor

Click to View Pricing, Inventory, Delivery & Lifecycle Information:

## Switchcraft:

[EN3C5F](#) [EN3C2FC](#) [EN3C3M16X](#) [EN3C4MCX](#) [EN3C3M](#) [EN3C2FCX](#) [EN3C3FX](#) [EN3C4FX](#) [EN3C4MX](#)  
[EN3C5MX](#) [EN3C6FX](#) [EN3C6MX](#) [EN3C8FX](#) [EN3C2F](#) [EN3C5FX](#) [EN3C3MX](#) [EN3C2FX](#) [EN3C13M26SX](#)  
[EN3C17M26X](#) [EN3C10F26SX](#) [EN3C17F26SX](#) [EN3C10F26X](#) [EN3C13F26X](#) [EN3C12F26SX](#) [EN3C14F26SX](#)  
[EN3C17F26X](#) [EN3C11F26X](#) [EN3C11F26SX](#) [EN3C16F26X](#) [EN3C17M26SX](#) [EN3C12M26SX](#) [EN3C15F26SX](#)  
[EN3C12M26X](#) [EN3C15M26X](#) [EN3C18M26SX](#) [EN3C10M26SX](#) [EN3C15M26SX](#) [EN3C15F26X](#) [EN3C10M26X](#)  
[EN3C16M26SX](#) [EN3C11M26X](#) [EN3C14M26SX](#) [EN3C16F26SX](#) [EN3C14F26X](#) [EN3C18M26X](#) [EN3C13M26X](#)  
[EN3C11M26SX](#) [EN3C16M26X](#) [EN3C13F26SX](#) [EN3C18F26SX](#) [EN3C14M26X](#) [EN3C18F26X](#) [EN3C12F26X](#)  
[EN3C2F16X](#) [EN3C2F16CX](#) [EN3C2F16CKX](#) [EN3C2F16KX](#) [EN3C2FCKX](#) [EN3C2FKX](#) [EN3C2M16CKX](#)  
[EN3C2M16CX](#) [EN3C2M16KX](#) [EN3C2M16X](#) [EN3C2MCKX](#) [EN3C2MCX](#) [EN3C2MKX](#) [EN3C2MX](#) [EN3C3F16CKX](#)  
[EN3C3F16CX](#) [EN3C3F16KX](#) [EN3C3F16X](#) [EN3C3FCKX](#) [EN3C3FCX](#) [EN3C3FKX](#) [EN3C3M16CKX](#) [EN3C3M16CX](#)  
[EN3C3M16KX](#) [EN3C3MCKX](#) [EN3C3MCX](#) [EN3C3MKX](#) [EN3C4CMX](#) [EN3C4FCKX](#) [EN3C4FCX](#) [EN3C4FKX](#)  
[EN3C4MCKX](#) [EN3C4MKX](#) [EN3C5FCKX](#) [EN3C5FCX](#) [EN3C5FKX](#) [EN3C5MCKX](#) [EN3C5MCX](#) [EN3C5MKX](#)  
[EN3C6FCKX](#) [EN3C6FCX](#) [EN3C6FKX](#) [EN3C6MCKX](#) [EN3C6MCX](#) [EN3C6MKX](#) [EN3C7FCKX](#) [EN3C7FCX](#)