

STABISTORS

Diodes with controlled conductance in a all-glass DO-7 envelope intended for low voltage regulation in circuits for clipping, coupling, clamping, meter protection, bias regulation and in many applications which require tight tolerances and low voltage levels. The series consists of 4 types with nominal voltages ranging from 1,4 to 3,6V with a tolerance of $\pm 5\%$.

QUICK REFERENCE DATA			
Regulation voltage range	V_F	nom.	1,4 to 3,6 V
Regulation voltage tolerance			± 5 %
Continuous reverse voltage	V_R	max.	10 V
Repetitive peak reverse voltage	V_{RRM}	max.	10 V
Repetitive peak forward current	I_{FRM}	max.	250 mA
Total power dissipation up to $T_{amb} = 32$ °C	P_{tot}	max.	400 mW
Operating junction temperature	T_j	max.	200 °C

MECHANICAL DATA

Dimensions in mm

DO-7

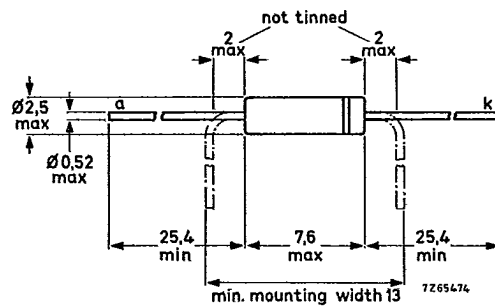

Cathode indicated by coloured band

T-11-21

RATINGS Limiting values in accordance with the Absolute Maximum System (IEC134)

Continuous reverse voltage	V_R	max.	10 V
Repetitive peak reverse voltage	V_{RRM}	max.	10 V
Repetitive peak forward current	I_{FRM}	max.	250 mA
Total power dissipation up to $T_{amb} = 32\text{ }^\circ\text{C}$	P_{tot}	max.	400 mW
Storage temperature	T_{stg}	-65 to +175	$^\circ\text{C}$
Operating junction temperature	T_j	max.	200 $^\circ\text{C}$

THERMAL RESISTANCE

From junction to ambient in free air	$R_{th\ j-a}$	=	0,42 K/mW
--------------------------------------	---------------	---	-----------

T-11-21

CHARACTERISTICS

$T_j = 25\text{ }^\circ\text{C}$ unless otherwise specified

BZX75-....	Regulation voltage			Temperature coefficient	Differential resistance	
	V_F (V)				r_{diff} (Ω); $f = 1\text{ kHz}$	
	at $I_F = 1\text{ mA}$			at $I_F = 1\text{ mA}$		
	min.		max.	typ.	typ.	
C1V4	1,16		1,34	-4	60	
C2V1	1,75		2,05	-6	90	
C2V8	2,33		2,70	-8	120	
C3V6	3,02		3,45	-10	150	

BZX75-....	at $I_F = 10\text{ mA}$			Temperature coefficient	at $I_F = 10\text{ mA}$	
	min.	nom.	max.		typ.	typ.
C1V4	1,33	1,40	1,47	-3,3	6	10
C2V1	1,99	2,10	2,21	-5,0	9	15
C2V8	2,66	2,80	2,94	-6,6	12	20
C3V6	3,42	3,60	3,78	-8,2	15	25

Reverse current

$V_R = 5\text{ V}$

BZX75-C1V4	}	$I_R < 500\text{ nA}$
BZX75-C2V1		
BZX75-C2V8	}	$I_R < 200\text{ nA}$
BZX75-C3V6		

Recovered charge when switched from

$I_F = 10\text{ mA}$ to $V_R = 5\text{ V}$; $R_L = 500\ \Omega$

$Q_s > 600\text{ pC}$

Diode capacitance

$V_R = 0$; $f = 1\text{ MHz}$

$C_d < 250\text{ pF}$

T-11-21

