

Radial Lead Type Monolithic Ceramic Capacitors



RDE Series (For General Use Only) (DC25V-DC1kV)

■ Features

1. Small size and large capacitance
2. Low ESR characteristics for high frequency
3. Meet LF (Lead Free) and HF (Halogen Free)
4. Flow soldering is available, but re-flow soldering is not available.

■ Applications

General electronic equipment

(Do not use for automotive-related power train and safety equipment.)

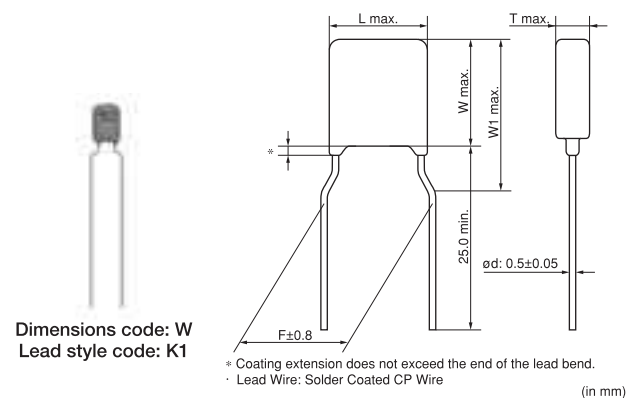
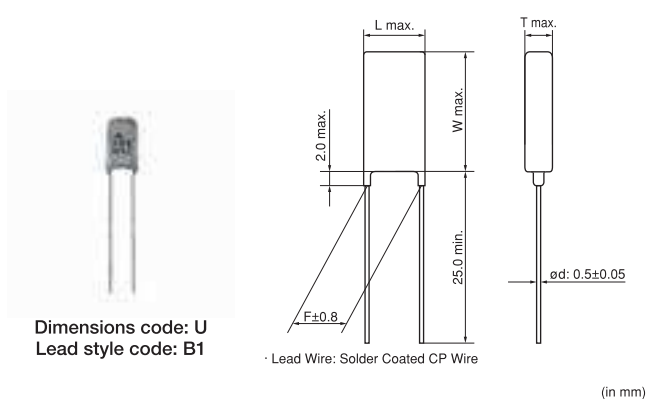
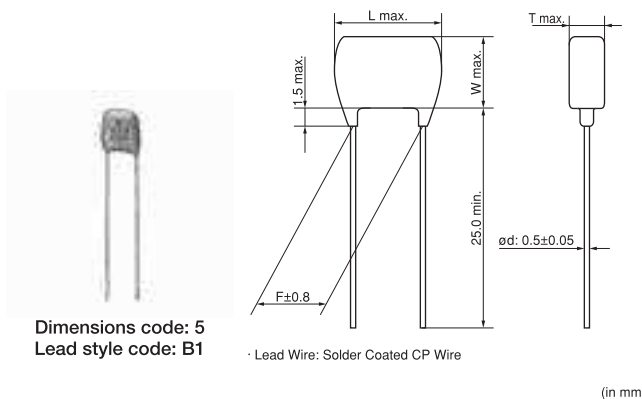
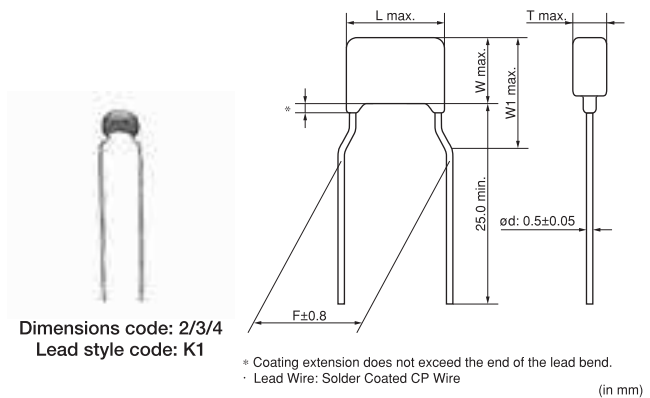
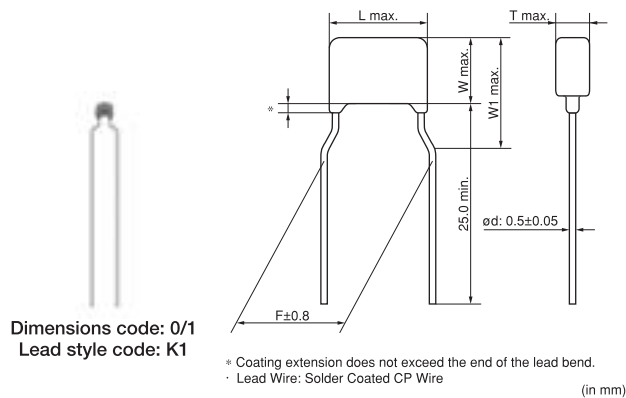
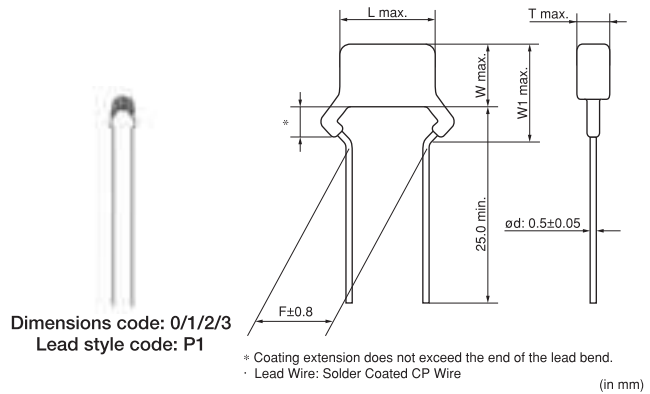

■ Dimensions

Dimensions and Lead Style Code	Dimensions (mm)					
	L	W	W1	T	F	d
0P1/0S1	5.0	3.5	6.0	See the individual product specification	2.5	0.5
0K1/0M1	4.0	3.5	6.0		5.0	0.5
1P1/1S1	5.0	3.5	5.0		2.5	0.5
1K1/1M1	4.5	3.5	5.0		5.0	0.5
2P1/2S1	5.5	4.0	6.0		2.5	0.5
2K1/2M1	5.5	4.0	6.0		5.0	0.5
3P1/3S1	5.5	5.0	7.5		2.5	0.5
3K1/3M1	5.5	5.0	7.5		5.0	0.5
4K1/4M1	7.5	5.5	8.0		5.0	0.5
5B1/5E1	7.5	7.5*	-		5.0	0.5
UB1/UE1	7.7	12.5*	-		5.0	0.5
WK1/WM1	5.5	7.5	10.0		5.0	0.5

*DC630V, DC1kV: W+0.5mm

■ Marking

Dimensions Code	Rated Voltage	DC25V		DC50V				DC100V			DC250V	DC630V	DC1kV	
		Temp. Char.	X7S	X7R	C0G	X7S	X7R	F	Y5V	C0G	X7S	X7R	X7R, U2J	
0			104K		-		473	103Z		-		-	-	-
1		224K		A 102J		224K			A 102J		224K	U 102J		-
2		M 475 K2C			M 475 K5C	M 105 K5C					M 105 K1C	M 103 J4U (U2J)	M 472 J7U (U2J)	M 102 JAU (U2J)
												M 473 K4C (X7R)	M 153 K7C (X7R)	M 102 KAC (X7R)
3, 4, W		M 226 K2C				M 335 K5C				M 225 K1C		M 473 J4U (U2J)	M 103 J7U (U2J)	M 472 JAU (U2J)
												M 224 K4C (X7R)	M 104 K7C (X7R)	M 333 KAC (X7R)
5, U													M 333 J7U (U2J)	M 103 JAU (U2J)
												M 474 K4C (X7R)	M 474 M7C (X7R)	M 104 KAC (X7R)
Temperature Characteristics	Marked with code (C0G char.: A, X7S/X7R char.: C, F/Y5V char.: F, U2J char.: U) A part is omitted (Please refer to the marking example.)													
Nominal Capacitance	Under 100pF: Actual value 100pF and over: Marked with 3 figures													
Capacitance Tolerance	Marked with code A part is omitted (Please refer to the marking example.)													
Rated Voltage	Marked with code (DC25V: 2, DC50V: 5, DC100V: 1, DC250V: 4, DC630V: 7, DC1kV: A) Lower horizontal line for F char. A part is omitted (Please refer to the marking example.)													
Manufacturer's Identification	Marked with M A part is omitted (Please refer to the marking example.)													

Temperature Compensating Type, C0G/U2J Characteristics

Part Number	Temp. Char.	Rated Voltage	Capacitance	Dimensions LxW (mm)	Dimension T (mm)	Lead Space F (mm)	Lead Style Code Bulk	Lead Style Code Taping
RDE5C1H1R0C0□□H03□	C0G (EIA)	50Vdc	1.0pF±0.25pF	4.0×3.5	2.5	5.0	K1	M1
RDE5C1H1R0C0□□H03□	C0G (EIA)	50Vdc	1.0pF±0.25pF	5.0×3.5	2.5	2.5	P1	S1
RDE5C1H2R0C0□□H03□	C0G (EIA)	50Vdc	2.0pF±0.25pF	4.0×3.5	2.5	5.0	K1	M1
RDE5C1H2R0C0□□H03□	C0G (EIA)	50Vdc	2.0pF±0.25pF	5.0×3.5	2.5	2.5	P1	S1
RDE5C1H3R0C0□□H03□	C0G (EIA)	50Vdc	3.0pF±0.25pF	4.0×3.5	2.5	5.0	K1	M1
RDE5C1H3R0C0□□H03□	C0G (EIA)	50Vdc	3.0pF±0.25pF	5.0×3.5	2.5	2.5	P1	S1
RDE5C1H4R0C0□□H03□	C0G (EIA)	50Vdc	4.0pF±0.25pF	4.0×3.5	2.5	5.0	K1	M1
RDE5C1H4R0C0□□H03□	C0G (EIA)	50Vdc	4.0pF±0.25pF	5.0×3.5	2.5	2.5	P1	S1
RDE5C1H5R0C0□□H03□	C0G (EIA)	50Vdc	5.0pF±0.25pF	4.0×3.5	2.5	5.0	K1	M1
RDE5C1H5R0C0□□H03□	C0G (EIA)	50Vdc	5.0pF±0.25pF	5.0×3.5	2.5	2.5	P1	S1
RDE5C1H6R0D0□□H03□	C0G (EIA)	50Vdc	6.0pF±0.5pF	4.0×3.5	2.5	5.0	K1	M1
RDE5C1H6R0D0□□H03□	C0G (EIA)	50Vdc	6.0pF±0.5pF	5.0×3.5	2.5	2.5	P1	S1
RDE5C1H7R0D0□□H03□	C0G (EIA)	50Vdc	7.0pF±0.5pF	4.0×3.5	2.5	5.0	K1	M1
RDE5C1H7R0D0□□H03□	C0G (EIA)	50Vdc	7.0pF±0.5pF	5.0×3.5	2.5	2.5	P1	S1

Continued from the preceding page.

Part Number	Temp. Char.	Rated Voltage	Capacitance	Dimensions LxW (mm)	Dimension T (mm)	Lead Space F (mm)	Lead Style Code Bulk	Lead Style Code Taping
RDE5C1H8R0D0□□H03□	C0G (EIA)	50Vdc	8.0pF±0.5pF	4.0×3.5	2.5	5.0	K1	M1
RDE5C1H8R0D0□□H03□	C0G (EIA)	50Vdc	8.0pF±0.5pF	5.0×3.5	2.5	2.5	P1	S1
RDE5C1H9R0D0□□H03□	C0G (EIA)	50Vdc	9.0pF±0.5pF	4.0×3.5	2.5	5.0	K1	M1
RDE5C1H9R0D0□□H03□	C0G (EIA)	50Vdc	9.0pF±0.5pF	5.0×3.5	2.5	2.5	P1	S1
RDE5C1H100J0□□H03□	C0G (EIA)	50Vdc	10pF±5%	4.0×3.5	2.5	5.0	K1	M1
RDE5C1H100J0□□H03□	C0G (EIA)	50Vdc	10pF±5%	5.0×3.5	2.5	2.5	P1	S1
RDE5C1H120J0□□H03□	C0G (EIA)	50Vdc	12pF±5%	4.0×3.5	2.5	5.0	K1	M1
RDE5C1H120J0□□H03□	C0G (EIA)	50Vdc	12pF±5%	5.0×3.5	2.5	2.5	P1	S1
RDE5C1H150J0□□H03□	C0G (EIA)	50Vdc	15pF±5%	4.0×3.5	2.5	5.0	K1	M1
RDE5C1H150J0□□H03□	C0G (EIA)	50Vdc	15pF±5%	5.0×3.5	2.5	2.5	P1	S1
RDE5C1H180J0□□H03□	C0G (EIA)	50Vdc	18pF±5%	4.0×3.5	2.5	5.0	K1	M1
RDE5C1H180J0□□H03□	C0G (EIA)	50Vdc	18pF±5%	5.0×3.5	2.5	2.5	P1	S1
RDE5C1H220J0□□H03□	C0G (EIA)	50Vdc	22pF±5%	4.0×3.5	2.5	5.0	K1	M1
RDE5C1H220J0□□H03□	C0G (EIA)	50Vdc	22pF±5%	5.0×3.5	2.5	2.5	P1	S1
RDE5C1H270J0□□H03□	C0G (EIA)	50Vdc	27pF±5%	4.0×3.5	2.5	5.0	K1	M1
RDE5C1H270J0□□H03□	C0G (EIA)	50Vdc	27pF±5%	5.0×3.5	2.5	2.5	P1	S1
RDE5C1H330J0□□H03□	C0G (EIA)	50Vdc	33pF±5%	4.0×3.5	2.5	5.0	K1	M1
RDE5C1H330J0□□H03□	C0G (EIA)	50Vdc	33pF±5%	5.0×3.5	2.5	2.5	P1	S1
RDE5C1H390J0□□H03□	C0G (EIA)	50Vdc	39pF±5%	4.0×3.5	2.5	5.0	K1	M1
RDE5C1H390J0□□H03□	C0G (EIA)	50Vdc	39pF±5%	5.0×3.5	2.5	2.5	P1	S1
RDE5C1H470J0□□H03□	C0G (EIA)	50Vdc	47pF±5%	4.0×3.5	2.5	5.0	K1	M1
RDE5C1H470J0□□H03□	C0G (EIA)	50Vdc	47pF±5%	5.0×3.5	2.5	2.5	P1	S1
RDE5C1H560J0□□H03□	C0G (EIA)	50Vdc	56pF±5%	4.0×3.5	2.5	5.0	K1	M1
RDE5C1H560J0□□H03□	C0G (EIA)	50Vdc	56pF±5%	5.0×3.5	2.5	2.5	P1	S1
RDE5C1H680J0□□H03□	C0G (EIA)	50Vdc	68pF±5%	4.0×3.5	2.5	5.0	K1	M1
RDE5C1H680J0□□H03□	C0G (EIA)	50Vdc	68pF±5%	5.0×3.5	2.5	2.5	P1	S1
RDE5C1H820J0□□H03□	C0G (EIA)	50Vdc	82pF±5%	4.0×3.5	2.5	5.0	K1	M1
RDE5C1H820J0□□H03□	C0G (EIA)	50Vdc	82pF±5%	5.0×3.5	2.5	2.5	P1	S1
RDE5C1H101J0□□H03□	C0G (EIA)	50Vdc	100pF±5%	4.0×3.5	2.5	5.0	K1	M1
RDE5C1H101J0□□H03□	C0G (EIA)	50Vdc	100pF±5%	5.0×3.5	2.5	2.5	P1	S1
RDE5C1H121J0□□H03□	C0G (EIA)	50Vdc	120pF±5%	4.0×3.5	2.5	5.0	K1	M1
RDE5C1H121J0□□H03□	C0G (EIA)	50Vdc	120pF±5%	5.0×3.5	2.5	2.5	P1	S1
RDE5C1H151J0□□H03□	C0G (EIA)	50Vdc	150pF±5%	4.0×3.5	2.5	5.0	K1	M1
RDE5C1H151J0□□H03□	C0G (EIA)	50Vdc	150pF±5%	5.0×3.5	2.5	2.5	P1	S1
RDE5C1H181J0□□H03□	C0G (EIA)	50Vdc	180pF±5%	4.0×3.5	2.5	5.0	K1	M1
RDE5C1H181J0□□H03□	C0G (EIA)	50Vdc	180pF±5%	5.0×3.5	2.5	2.5	P1	S1
RDE5C1H221J0□□H03□	C0G (EIA)	50Vdc	220pF±5%	4.0×3.5	2.5	5.0	K1	M1
RDE5C1H221J0□□H03□	C0G (EIA)	50Vdc	220pF±5%	5.0×3.5	2.5	2.5	P1	S1
RDE5C1H271J0□□H03□	C0G (EIA)	50Vdc	270pF±5%	4.0×3.5	2.5	5.0	K1	M1
RDE5C1H271J0□□H03□	C0G (EIA)	50Vdc	270pF±5%	5.0×3.5	2.5	2.5	P1	S1
RDE5C1H331J0□□H03□	C0G (EIA)	50Vdc	330pF±5%	4.0×3.5	2.5	5.0	K1	M1
RDE5C1H331J0□□H03□	C0G (EIA)	50Vdc	330pF±5%	5.0×3.5	2.5	2.5	P1	S1
RDE5C1H391J0□□H03□	C0G (EIA)	50Vdc	390pF±5%	4.0×3.5	2.5	5.0	K1	M1
RDE5C1H391J0□□H03□	C0G (EIA)	50Vdc	390pF±5%	5.0×3.5	2.5	2.5	P1	S1
RDE5C1H471J0□□H03□	C0G (EIA)	50Vdc	470pF±5%	4.0×3.5	2.5	5.0	K1	M1
RDE5C1H471J0□□H03□	C0G (EIA)	50Vdc	470pF±5%	5.0×3.5	2.5	2.5	P1	S1
RDE5C1H561J0□□H03□	C0G (EIA)	50Vdc	560pF±5%	4.0×3.5	2.5	5.0	K1	M1
RDE5C1H561J0□□H03□	C0G (EIA)	50Vdc	560pF±5%	5.0×3.5	2.5	2.5	P1	S1
RDE5C1H681J0□□H03□	C0G (EIA)	50Vdc	680pF±5%	4.0×3.5	2.5	5.0	K1	M1
RDE5C1H681J0□□H03□	C0G (EIA)	50Vdc	680pF±5%	5.0×3.5	2.5	2.5	P1	S1
RDE5C1H821J0□□H03□	C0G (EIA)	50Vdc	820pF±5%	4.0×3.5	2.5	5.0	K1	M1
RDE5C1H821J0□□H03□	C0G (EIA)	50Vdc	820pF±5%	5.0×3.5	2.5	2.5	P1	S1
RDE5C1H102J0□□H03□	C0G (EIA)	50Vdc	1000pF±5%	4.0×3.5	2.5	5.0	K1	M1
RDE5C1H102J0□□H03□	C0G (EIA)	50Vdc	1000pF±5%	5.0×3.5	2.5	2.5	P1	S1
RDE5C1H122J0□□H03□	C0G (EIA)	50Vdc	1200pF±5%	4.0×3.5	2.5	5.0	K1	M1
RDE5C1H122J0□□H03□	C0G (EIA)	50Vdc	1200pF±5%	5.0×3.5	2.5	2.5	P1	S1
RDE5C1H152J0□□H03□	C0G (EIA)	50Vdc	1500pF±5%	4.0×3.5	2.5	5.0	K1	M1

Continued from the preceding page.

Part Number	Temp. Char.	Rated Voltage	Capacitance	Dimensions LxW (mm)	Dimension T (mm)	Lead Space F (mm)	Lead Style Code Bulk	Lead Style Code Taping
RDE5C1H152J0□□H03□	C0G (EIA)	50Vdc	1500pF±5%	5.0×3.5	2.5	2.5	P1	S1
RDE5C1H182J0□□H03□	C0G (EIA)	50Vdc	1800pF±5%	4.0×3.5	2.5	5.0	K1	M1
RDE5C1H182J0□□H03□	C0G (EIA)	50Vdc	1800pF±5%	5.0×3.5	2.5	2.5	P1	S1
RDE5C1H222J0□□H03□	C0G (EIA)	50Vdc	2200pF±5%	4.0×3.5	2.5	5.0	K1	M1
RDE5C1H222J0□□H03□	C0G (EIA)	50Vdc	2200pF±5%	5.0×3.5	2.5	2.5	P1	S1
RDE5C1H272J0□□H03□	C0G (EIA)	50Vdc	2700pF±5%	4.0×3.5	2.5	5.0	K1	M1
RDE5C1H272J0□□H03□	C0G (EIA)	50Vdc	2700pF±5%	5.0×3.5	2.5	2.5	P1	S1
RDE5C1H332J0□□H03□	C0G (EIA)	50Vdc	3300pF±5%	4.0×3.5	2.5	5.0	K1	M1
RDE5C1H332J0□□H03□	C0G (EIA)	50Vdc	3300pF±5%	5.0×3.5	2.5	2.5	P1	S1
RDE5C1H392J0□□H03□	C0G (EIA)	50Vdc	3900pF±5%	4.0×3.5	2.5	5.0	K1	M1
RDE5C1H392J0□□H03□	C0G (EIA)	50Vdc	3900pF±5%	5.0×3.5	2.5	2.5	P1	S1
RDE5C1H472J1□□H03□	C0G (EIA)	50Vdc	4700pF±5%	4.5×3.5	3.15	5.0	K1	M1
RDE5C1H472J1□□H03□	C0G (EIA)	50Vdc	4700pF±5%	5.0×3.5	3.15	2.5	P1	S1
RDE5C1H562J1□□H03□	C0G (EIA)	50Vdc	5600pF±5%	4.5×3.5	3.15	5.0	K1	M1
RDE5C1H562J1□□H03□	C0G (EIA)	50Vdc	5600pF±5%	5.0×3.5	3.15	2.5	P1	S1
RDE5C1H682J1□□H03□	C0G (EIA)	50Vdc	6800pF±5%	4.5×3.5	3.15	5.0	K1	M1
RDE5C1H682J1□□H03□	C0G (EIA)	50Vdc	6800pF±5%	5.0×3.5	3.15	2.5	P1	S1
RDE5C1H822J1□□H03□	C0G (EIA)	50Vdc	8200pF±5%	4.5×3.5	3.15	5.0	K1	M1
RDE5C1H822J1□□H03□	C0G (EIA)	50Vdc	8200pF±5%	5.0×3.5	3.15	2.5	P1	S1
RDE5C1H103J1□□H03□	C0G (EIA)	50Vdc	10000pF±5%	4.5×3.5	3.15	5.0	K1	M1
RDE5C1H103J1□□H03□	C0G (EIA)	50Vdc	10000pF±5%	5.0×3.5	3.15	2.5	P1	S1
RDE5C1H123J1□□H03□	C0G (EIA)	50Vdc	12000pF±5%	4.5×3.5	3.15	5.0	K1	M1
RDE5C1H123J1□□H03□	C0G (EIA)	50Vdc	12000pF±5%	5.0×3.5	3.15	2.5	P1	S1
RDE5C1H153J1□□H03□	C0G (EIA)	50Vdc	15000pF±5%	4.5×3.5	3.15	5.0	K1	M1
RDE5C1H153J1□□H03□	C0G (EIA)	50Vdc	15000pF±5%	5.0×3.5	3.15	2.5	P1	S1
RDE5C1H183J1□□H03□	C0G (EIA)	50Vdc	18000pF±5%	4.5×3.5	3.15	5.0	K1	M1
RDE5C1H183J1□□H03□	C0G (EIA)	50Vdc	18000pF±5%	5.0×3.5	3.15	2.5	P1	S1
RDE5C1H223J1□□H03□	C0G (EIA)	50Vdc	22000pF±5%	4.5×3.5	3.15	5.0	K1	M1
RDE5C1H223J1□□H03□	C0G (EIA)	50Vdc	22000pF±5%	5.0×3.5	3.15	2.5	P1	S1
RDE5C2A1R0C0□□H03□	C0G (EIA)	100Vdc	1.0pF±0.25pF	4.0×3.5	2.5	5.0	K1	M1
RDE5C2A1R0C0□□H03□	C0G (EIA)	100Vdc	1.0pF±0.25pF	5.0×3.5	2.5	2.5	P1	S1
RDE5C2A2R0C0□□H03□	C0G (EIA)	100Vdc	2.0pF±0.25pF	4.0×3.5	2.5	5.0	K1	M1
RDE5C2A2R0C0□□H03□	C0G (EIA)	100Vdc	2.0pF±0.25pF	5.0×3.5	2.5	2.5	P1	S1
RDE5C2A3R0C0□□H03□	C0G (EIA)	100Vdc	3.0pF±0.25pF	4.0×3.5	2.5	5.0	K1	M1
RDE5C2A3R0C0□□H03□	C0G (EIA)	100Vdc	3.0pF±0.25pF	5.0×3.5	2.5	2.5	P1	S1
RDE5C2A4R0C0□□H03□	C0G (EIA)	100Vdc	4.0pF±0.25pF	4.0×3.5	2.5	5.0	K1	M1
RDE5C2A4R0C0□□H03□	C0G (EIA)	100Vdc	4.0pF±0.25pF	5.0×3.5	2.5	2.5	P1	S1
RDE5C2A5R0C0□□H03□	C0G (EIA)	100Vdc	5.0pF±0.25pF	4.0×3.5	2.5	5.0	K1	M1
RDE5C2A5R0C0□□H03□	C0G (EIA)	100Vdc	5.0pF±0.25pF	5.0×3.5	2.5	2.5	P1	S1
RDE5C2A6R0D0□□H03□	C0G (EIA)	100Vdc	6.0pF±0.5pF	4.0×3.5	2.5	5.0	K1	M1
RDE5C2A6R0D0□□H03□	C0G (EIA)	100Vdc	6.0pF±0.5pF	5.0×3.5	2.5	2.5	P1	S1
RDE5C2A7R0D0□□H03□	C0G (EIA)	100Vdc	7.0pF±0.5pF	4.0×3.5	2.5	5.0	K1	M1
RDE5C2A7R0D0□□H03□	C0G (EIA)	100Vdc	7.0pF±0.5pF	5.0×3.5	2.5	2.5	P1	S1
RDE5C2A8R0D0□□H03□	C0G (EIA)	100Vdc	8.0pF±0.5pF	4.0×3.5	2.5	5.0	K1	M1
RDE5C2A8R0D0□□H03□	C0G (EIA)	100Vdc	8.0pF±0.5pF	5.0×3.5	2.5	2.5	P1	S1
RDE5C2A9R0D0□□H03□	C0G (EIA)	100Vdc	9.0pF±0.5pF	4.0×3.5	2.5	5.0	K1	M1
RDE5C2A9R0D0□□H03□	C0G (EIA)	100Vdc	9.0pF±0.5pF	5.0×3.5	2.5	2.5	P1	S1
RDE5C2A100J0□□H03□	C0G (EIA)	100Vdc	10pF±5%	4.0×3.5	2.5	5.0	K1	M1
RDE5C2A100J0□□H03□	C0G (EIA)	100Vdc	10pF±5%	5.0×3.5	2.5	2.5	P1	S1
RDE5C2A120J0□□H03□	C0G (EIA)	100Vdc	12pF±5%	4.0×3.5	2.5	5.0	K1	M1
RDE5C2A120J0□□H03□	C0G (EIA)	100Vdc	12pF±5%	5.0×3.5	2.5	2.5	P1	S1
RDE5C2A150J0□□H03□	C0G (EIA)	100Vdc	15pF±5%	4.0×3.5	2.5	5.0	K1	M1
RDE5C2A150J0□□H03□	C0G (EIA)	100Vdc	15pF±5%	5.0×3.5	2.5	2.5	P1	S1
RDE5C2A180J0□□H03□	C0G (EIA)	100Vdc	18pF±5%	4.0×3.5	2.5	5.0	K1	M1
RDE5C2A180J0□□H03□	C0G (EIA)	100Vdc	18pF±5%	5.0×3.5	2.5	2.5	P1	S1
RDE5C2A220J0□□H03□	C0G (EIA)	100Vdc	22pF±5%	4.0×3.5	2.5	5.0	K1	M1
RDE5C2A220J0□□H03□	C0G (EIA)	100Vdc	22pF±5%	5.0×3.5	2.5	2.5	P1	S1

Continued from the preceding page.

Part Number	Temp. Char.	Rated Voltage	Capacitance	Dimensions LxW (mm)	Dimension T (mm)	Lead Space F (mm)	Lead Style Code Bulk	Lead Style Code Taping
RDE5C2A270J0□□H03□	C0G (EIA)	100Vdc	27pF±5%	4.0×3.5	2.5	5.0	K1	M1
RDE5C2A270J0□□H03□	C0G (EIA)	100Vdc	27pF±5%	5.0×3.5	2.5	2.5	P1	S1
RDE5C2A330J0□□H03□	C0G (EIA)	100Vdc	33pF±5%	4.0×3.5	2.5	5.0	K1	M1
RDE5C2A330J0□□H03□	C0G (EIA)	100Vdc	33pF±5%	5.0×3.5	2.5	2.5	P1	S1
RDE5C2A390J0□□H03□	C0G (EIA)	100Vdc	39pF±5%	4.0×3.5	2.5	5.0	K1	M1
RDE5C2A390J0□□H03□	C0G (EIA)	100Vdc	39pF±5%	5.0×3.5	2.5	2.5	P1	S1
RDE5C2A470J0□□H03□	C0G (EIA)	100Vdc	47pF±5%	4.0×3.5	2.5	5.0	K1	M1
RDE5C2A470J0□□H03□	C0G (EIA)	100Vdc	47pF±5%	5.0×3.5	2.5	2.5	P1	S1
RDE5C2A560J0□□H03□	C0G (EIA)	100Vdc	56pF±5%	4.0×3.5	2.5	5.0	K1	M1
RDE5C2A560J0□□H03□	C0G (EIA)	100Vdc	56pF±5%	5.0×3.5	2.5	2.5	P1	S1
RDE5C2A680J0□□H03□	C0G (EIA)	100Vdc	68pF±5%	4.0×3.5	2.5	5.0	K1	M1
RDE5C2A680J0□□H03□	C0G (EIA)	100Vdc	68pF±5%	5.0×3.5	2.5	2.5	P1	S1
RDE5C2A820J0□□H03□	C0G (EIA)	100Vdc	82pF±5%	4.0×3.5	2.5	5.0	K1	M1
RDE5C2A820J0□□H03□	C0G (EIA)	100Vdc	82pF±5%	5.0×3.5	2.5	2.5	P1	S1
RDE5C2A101J0□□H03□	C0G (EIA)	100Vdc	100pF±5%	4.0×3.5	2.5	5.0	K1	M1
RDE5C2A101J0□□H03□	C0G (EIA)	100Vdc	100pF±5%	5.0×3.5	2.5	2.5	P1	S1
RDE5C2A121J0□□H03□	C0G (EIA)	100Vdc	120pF±5%	4.0×3.5	2.5	5.0	K1	M1
RDE5C2A121J0□□H03□	C0G (EIA)	100Vdc	120pF±5%	5.0×3.5	2.5	2.5	P1	S1
RDE5C2A151J0□□H03□	C0G (EIA)	100Vdc	150pF±5%	4.0×3.5	2.5	5.0	K1	M1
RDE5C2A151J0□□H03□	C0G (EIA)	100Vdc	150pF±5%	5.0×3.5	2.5	2.5	P1	S1
RDE5C2A181J0□□H03□	C0G (EIA)	100Vdc	180pF±5%	4.0×3.5	2.5	5.0	K1	M1
RDE5C2A181J0□□H03□	C0G (EIA)	100Vdc	180pF±5%	5.0×3.5	2.5	2.5	P1	S1
RDE5C2A221J0□□H03□	C0G (EIA)	100Vdc	220pF±5%	4.0×3.5	2.5	5.0	K1	M1
RDE5C2A221J0□□H03□	C0G (EIA)	100Vdc	220pF±5%	5.0×3.5	2.5	2.5	P1	S1
RDE5C2A271J0□□H03□	C0G (EIA)	100Vdc	270pF±5%	4.0×3.5	2.5	5.0	K1	M1
RDE5C2A271J0□□H03□	C0G (EIA)	100Vdc	270pF±5%	5.0×3.5	2.5	2.5	P1	S1
RDE5C2A331J0□□H03□	C0G (EIA)	100Vdc	330pF±5%	4.0×3.5	2.5	5.0	K1	M1
RDE5C2A331J0□□H03□	C0G (EIA)	100Vdc	330pF±5%	5.0×3.5	2.5	2.5	P1	S1
RDE5C2A391J0□□H03□	C0G (EIA)	100Vdc	390pF±5%	4.0×3.5	2.5	5.0	K1	M1
RDE5C2A391J0□□H03□	C0G (EIA)	100Vdc	390pF±5%	5.0×3.5	2.5	2.5	P1	S1
RDE5C2A471J0□□H03□	C0G (EIA)	100Vdc	470pF±5%	4.0×3.5	2.5	5.0	K1	M1
RDE5C2A471J0□□H03□	C0G (EIA)	100Vdc	470pF±5%	5.0×3.5	2.5	2.5	P1	S1
RDE5C2A561J0□□H03□	C0G (EIA)	100Vdc	560pF±5%	4.0×3.5	2.5	5.0	K1	M1
RDE5C2A561J0□□H03□	C0G (EIA)	100Vdc	560pF±5%	5.0×3.5	2.5	2.5	P1	S1
RDE5C2A681J0□□H03□	C0G (EIA)	100Vdc	680pF±5%	4.0×3.5	2.5	5.0	K1	M1
RDE5C2A681J0□□H03□	C0G (EIA)	100Vdc	680pF±5%	5.0×3.5	2.5	2.5	P1	S1
RDE5C2A821J0□□H03□	C0G (EIA)	100Vdc	820pF±5%	4.0×3.5	2.5	5.0	K1	M1
RDE5C2A821J0□□H03□	C0G (EIA)	100Vdc	820pF±5%	5.0×3.5	2.5	2.5	P1	S1
RDE5C2A102J0□□H03□	C0G (EIA)	100Vdc	1000pF±5%	4.0×3.5	2.5	5.0	K1	M1
RDE5C2A102J0□□H03□	C0G (EIA)	100Vdc	1000pF±5%	5.0×3.5	2.5	2.5	P1	S1
RDE5C2A122J0□□H03□	C0G (EIA)	100Vdc	1200pF±5%	4.0×3.5	2.5	5.0	K1	M1
RDE5C2A122J0□□H03□	C0G (EIA)	100Vdc	1200pF±5%	5.0×3.5	2.5	2.5	P1	S1
RDE5C2A152J0□□H03□	C0G (EIA)	100Vdc	1500pF±5%	4.0×3.5	2.5	5.0	K1	M1
RDE5C2A152J0□□H03□	C0G (EIA)	100Vdc	1500pF±5%	5.0×3.5	2.5	2.5	P1	S1
RDE5C2A182J1□□H03□	C0G (EIA)	100Vdc	1800pF±5%	4.5×3.5	3.15	5.0	K1	M1
RDE5C2A182J1□□H03□	C0G (EIA)	100Vdc	1800pF±5%	5.0×3.5	3.15	2.5	P1	S1
RDE5C2A222J1□□H03□	C0G (EIA)	100Vdc	2200pF±5%	4.5×3.5	3.15	5.0	K1	M1
RDE5C2A222J1□□H03□	C0G (EIA)	100Vdc	2200pF±5%	5.0×3.5	3.15	2.5	P1	S1
RDE5C2A272J1□□H03□	C0G (EIA)	100Vdc	2700pF±5%	4.5×3.5	3.15	5.0	K1	M1
RDE5C2A272J1□□H03□	C0G (EIA)	100Vdc	2700pF±5%	5.0×3.5	3.15	2.5	P1	S1
RDE5C2A332J1□□H03□	C0G (EIA)	100Vdc	3300pF±5%	4.5×3.5	3.15	5.0	K1	M1
RDE5C2A332J1□□H03□	C0G (EIA)	100Vdc	3300pF±5%	5.0×3.5	3.15	2.5	P1	S1
RDE7U2E101J1□□H03□	U2J (EIA)	250Vdc	100pF±5%	4.5×3.5	3.15	5.0	K1	M1
RDE7U2E151J1□□H03□	U2J (EIA)	250Vdc	150pF±5%	4.5×3.5	3.15	5.0	K1	M1
RDE7U2E221J1□□H03□	U2J (EIA)	250Vdc	220pF±5%	4.5×3.5	3.15	5.0	K1	M1
RDE7U2E331J1□□H03□	U2J (EIA)	250Vdc	330pF±5%	4.5×3.5	3.15	5.0	K1	M1
RDE7U2E471J1□□H03□	U2J (EIA)	250Vdc	470pF±5%	4.5×3.5	3.15	5.0	K1	M1

Continued from the preceding page.

Part Number	Temp. Char.	Rated Voltage	Capacitance	Dimensions LxW (mm)	Dimension T (mm)	Lead Space F (mm)	Lead Style Code Bulk	Lead Style Code Taping
RDE7U2E681J1□□H03□	U2J (EIA)	250Vdc	680pF±5%	4.5×3.5	3.15	5.0	K1	M1
RDE7U2E102J1□□H03□	U2J (EIA)	250Vdc	1000pF±5%	4.5×3.5	3.15	5.0	K1	M1
RDE7U2E152J1□□H03□	U2J (EIA)	250Vdc	1500pF±5%	4.5×3.5	3.15	5.0	K1	M1
RDE7U2E222J1□□H03□	U2J (EIA)	250Vdc	2200pF±5%	4.5×3.5	3.15	5.0	K1	M1
RDE7U2E332J1□□H03□	U2J (EIA)	250Vdc	3300pF±5%	4.5×3.5	3.15	5.0	K1	M1
RDE7U2E472J1□□H03□	U2J (EIA)	250Vdc	4700pF±5%	4.5×3.5	3.15	5.0	K1	M1
RDE7U2E682J2□□H03□	U2J (EIA)	250Vdc	6800pF±5%	5.5×4.0	3.15	5.0	K1	M1
RDE7U2E103J2□□H03□	U2J (EIA)	250Vdc	10000pF±5%	5.5×4.0	3.15	5.0	K1	M1
RDE7U2E153J2□□H03□	U2J (EIA)	250Vdc	15000pF±5%	5.5×4.0	3.15	5.0	K1	M1
RDE7U2E223J2□□H03□	U2J (EIA)	250Vdc	22000pF±5%	5.5×4.0	3.15	5.0	K1	M1
RDE7U2E333J3□□H03□	U2J (EIA)	250Vdc	33000pF±5%	5.5×5.0	4.0	5.0	K1	M1
RDE7U2E473J3□□H03□	U2J (EIA)	250Vdc	47000pF±5%	5.5×5.0	4.0	5.0	K1	M1
RDE7U2J100J2□□H03□	U2J (EIA)	630Vdc	10pF±5%	5.5×4.0	3.15	5.0	K1	M1
RDE7U2J150J2□□H03□	U2J (EIA)	630Vdc	15pF±5%	5.5×4.0	3.15	5.0	K1	M1
RDE7U2J220J2□□H03□	U2J (EIA)	630Vdc	22pF±5%	5.5×4.0	3.15	5.0	K1	M1
RDE7U2J330J2□□H03□	U2J (EIA)	630Vdc	33pF±5%	5.5×4.0	3.15	5.0	K1	M1
RDE7U2J470J2□□H03□	U2J (EIA)	630Vdc	47pF±5%	5.5×4.0	3.15	5.0	K1	M1
RDE7U2J680J2□□H03□	U2J (EIA)	630Vdc	68pF±5%	5.5×4.0	3.15	5.0	K1	M1
RDE7U2J101J2□□H03□	U2J (EIA)	630Vdc	100pF±5%	5.5×4.0	3.15	5.0	K1	M1
RDE7U2J151J2□□H03□	U2J (EIA)	630Vdc	150pF±5%	5.5×4.0	3.15	5.0	K1	M1
RDE7U2J221J2□□H03□	U2J (EIA)	630Vdc	220pF±5%	5.5×4.0	3.15	5.0	K1	M1
RDE7U2J331J2□□H03□	U2J (EIA)	630Vdc	330pF±5%	5.5×4.0	3.15	5.0	K1	M1
RDE7U2J471J2□□H03□	U2J (EIA)	630Vdc	470pF±5%	5.5×4.0	3.15	5.0	K1	M1
RDE7U2J681J2□□H03□	U2J (EIA)	630Vdc	680pF±5%	5.5×4.0	3.15	5.0	K1	M1
RDE7U2J102J2□□H03□	U2J (EIA)	630Vdc	1000pF±5%	5.5×4.0	3.15	5.0	K1	M1
RDE7U2J152J2□□H03□	U2J (EIA)	630Vdc	1500pF±5%	5.5×4.0	3.15	5.0	K1	M1
RDE7U2J222J2□□H03□	U2J (EIA)	630Vdc	2200pF±5%	5.5×4.0	3.15	5.0	K1	M1
RDE7U2J332J2□□H03□	U2J (EIA)	630Vdc	3300pF±5%	5.5×4.0	3.15	5.0	K1	M1
RDE7U2J472J2□□H03□	U2J (EIA)	630Vdc	4700pF±5%	5.5×4.0	3.15	5.0	K1	M1
RDE7U2J682J3□□H03□	U2J (EIA)	630Vdc	6800pF±5%	5.5×5.0	4.0	5.0	K1	M1
RDE7U2J103J3□□H03□	U2J (EIA)	630Vdc	10000pF±5%	5.5×5.0	4.0	5.0	K1	M1
RDE7U2J153J4□□H03□	U2J (EIA)	630Vdc	15000pF±5%	7.5×5.5	4.0	5.0	K1	M1
RDE7U2J223J4□□H03□	U2J (EIA)	630Vdc	22000pF±5%	7.5×5.5	4.0	5.0	K1	M1
RDE7U2J333J5□□H03□	U2J (EIA)	630Vdc	33000pF±5%	7.5×8.0	4.0	5.0	B1	E1
RDE7U2J473J5□□H03□	U2J (EIA)	630Vdc	47000pF±5%	7.5×8.0	4.0	5.0	B1	E1
RDE7U2J943JU□□H03□	U2J (EIA)	630Vdc	94000pF±5%	7.7×13.0	4.0	5.0	B1	E1
RDE7U3A100J2□□H03□	U2J (EIA)	1000Vdc	10pF±5%	5.5×4.0	3.15	5.0	K1	M1
RDE7U3A150J2□□H03□	U2J (EIA)	1000Vdc	15pF±5%	5.5×4.0	3.15	5.0	K1	M1
RDE7U3A220J2□□H03□	U2J (EIA)	1000Vdc	22pF±5%	5.5×4.0	3.15	5.0	K1	M1
RDE7U3A330J2□□H03□	U2J (EIA)	1000Vdc	33pF±5%	5.5×4.0	3.15	5.0	K1	M1
RDE7U3A470J2□□H03□	U2J (EIA)	1000Vdc	47pF±5%	5.5×4.0	3.15	5.0	K1	M1
RDE7U3A680J2□□H03□	U2J (EIA)	1000Vdc	68pF±5%	5.5×4.0	3.15	5.0	K1	M1
RDE7U3A101J2□□H03□	U2J (EIA)	1000Vdc	100pF±5%	5.5×4.0	3.15	5.0	K1	M1
RDE7U3A151J2□□H03□	U2J (EIA)	1000Vdc	150pF±5%	5.5×4.0	3.15	5.0	K1	M1
RDE7U3A221J2□□H03□	U2J (EIA)	1000Vdc	220pF±5%	5.5×4.0	3.15	5.0	K1	M1
RDE7U3A331J2□□H03□	U2J (EIA)	1000Vdc	330pF±5%	5.5×4.0	3.15	5.0	K1	M1
RDE7U3A471J2□□H03□	U2J (EIA)	1000Vdc	470pF±5%	5.5×4.0	3.15	5.0	K1	M1
RDE7U3A681J2□□H03□	U2J (EIA)	1000Vdc	680pF±5%	5.5×4.0	3.15	5.0	K1	M1
RDE7U3A102J2□□H03□	U2J (EIA)	1000Vdc	1000pF±5%	5.5×4.0	3.15	5.0	K1	M1
RDE7U3A152J3□□H03□	U2J (EIA)	1000Vdc	1500pF±5%	5.5×5.0	4.0	5.0	K1	M1
RDE7U3A222J3□□H03□	U2J (EIA)	1000Vdc	2200pF±5%	5.5×5.0	4.0	5.0	K1	M1
RDE7U3A332J4□□H03□	U2J (EIA)	1000Vdc	3300pF±5%	7.5×5.5	4.0	5.0	K1	M1
RDE7U3A472J4□□H03□	U2J (EIA)	1000Vdc	4700pF±5%	7.5×5.5	4.0	5.0	K1	M1
RDE7U3A682J5□□H03□	U2J (EIA)	1000Vdc	6800pF±5%	7.5×8.0	4.0	5.0	B1	E1
RDE7U3A103J5□□H03□	U2J (EIA)	1000Vdc	10000pF±5%	7.5×8.0	4.0	5.0	B1	E1
RDE7U3A203JU□□H03□	U2J (EIA)	1000Vdc	20000pF±5%	7.7×13.0	4.0	5.0	B1	E1

Two blank columns are filled with the lead style code. Please refer to the 3 columns on the right for the appropriate code.

High Dielectric Constant Type, X7R/X7S Characteristics

Part Number	Temp. Char.	Rated Voltage	Capacitance	Dimensions LxW (mm)	Dimension T (mm)	Lead Space F (mm)	Lead Style Code Bulk	Lead Style Code Taping
RDER71E104K0□□H03□	X7R (EIA)	25Vdc	0.1μF±10%	4.0×3.5	2.5	5.0	K1	M1
RDER71E104K0□□H03□	X7R (EIA)	25Vdc	0.1μF±10%	5.0×3.5	2.5	2.5	P1	S1
RDEC71E224K0□□H03□	X7S (EIA)	25Vdc	0.22μF±10%	4.0×3.5	2.5	5.0	K1	M1
RDEC71E224K0□□H03□	X7S (EIA)	25Vdc	0.22μF±10%	5.0×3.5	2.5	2.5	P1	S1
RDEC71E474K0□□H03□	X7S (EIA)	25Vdc	0.47μF±10%	4.0×3.5	2.5	5.0	K1	M1
RDEC71E474K0□□H03□	X7S (EIA)	25Vdc	0.47μF±10%	5.0×3.5	2.5	2.5	P1	S1
RDEC71E105K0□□H03□	X7S (EIA)	25Vdc	1.0μF±10%	4.0×3.5	2.5	5.0	K1	M1
RDEC71E105K0□□H03□	X7S (EIA)	25Vdc	1.0μF±10%	5.0×3.5	2.5	2.5	P1	S1
RDEC71E225K1□□H03□	X7S (EIA)	25Vdc	2.2μF±10%	4.5×3.5	3.15	5.0	K1	M1
RDEC71E225K1□□H03□	X7S (EIA)	25Vdc	2.2μF±10%	5.0×3.5	3.15	2.5	P1	S1
RDEC71E475K2□□H03□	X7S (EIA)	25Vdc	4.7μF±10%	5.5×4.0	3.15	2.5	P1	S1
RDEC71E475K2□□H03□	X7S (EIA)	25Vdc	4.7μF±10%	5.5×4.0	3.15	5.0	K1	M1
RDEC71E106K2□□H03□	X7S (EIA)	25Vdc	10μF±10%	5.5×4.0	3.15	2.5	P1	S1
RDEC71E106K2□□H03□	X7S (EIA)	25Vdc	10μF±10%	5.5×4.0	3.15	5.0	K1	M1
RDEC71E226K3□□H03□	X7S (EIA)	25Vdc	22μF±10%	5.5×5.0	4.0	2.5	P1	S1
RDEC71E226K3□□H03□	X7S (EIA)	25Vdc	22μF±10%	5.5×5.0	4.0	5.0	K1	M1
RDEC71E476MW□□H03□	X7S (EIA)	25Vdc	47μF±20%	5.5×7.5	4.0	5.0	K1	M1
RDER71H221K0□□H03□	X7R (EIA)	50Vdc	220pF±10%	4.0×3.5	2.5	5.0	K1	M1
RDER71H221K0□□H03□	X7R (EIA)	50Vdc	220pF±10%	5.0×3.5	2.5	2.5	P1	S1
RDER71H331K0□□H03□	X7R (EIA)	50Vdc	330pF±10%	4.0×3.5	2.5	5.0	K1	M1
RDER71H331K0□□H03□	X7R (EIA)	50Vdc	330pF±10%	5.0×3.5	2.5	2.5	P1	S1
RDER71H471K0□□H03□	X7R (EIA)	50Vdc	470pF±10%	4.0×3.5	2.5	5.0	K1	M1
RDER71H471K0□□H03□	X7R (EIA)	50Vdc	470pF±10%	5.0×3.5	2.5	2.5	P1	S1
RDER71H681K0□□H03□	X7R (EIA)	50Vdc	680pF±10%	4.0×3.5	2.5	5.0	K1	M1
RDER71H681K0□□H03□	X7R (EIA)	50Vdc	680pF±10%	5.0×3.5	2.5	2.5	P1	S1
RDER71H102K0□□H03□	X7R (EIA)	50Vdc	1000pF±10%	4.0×3.5	2.5	5.0	K1	M1
RDER71H102K0□□H03□	X7R (EIA)	50Vdc	1000pF±10%	5.0×3.5	2.5	2.5	P1	S1
RDER71H152K0□□H03□	X7R (EIA)	50Vdc	1500pF±10%	4.0×3.5	2.5	5.0	K1	M1
RDER71H152K0□□H03□	X7R (EIA)	50Vdc	1500pF±10%	5.0×3.5	2.5	2.5	P1	S1
RDER71H222K0□□H03□	X7R (EIA)	50Vdc	2200pF±10%	4.0×3.5	2.5	5.0	K1	M1
RDER71H222K0□□H03□	X7R (EIA)	50Vdc	2200pF±10%	5.0×3.5	2.5	2.5	P1	S1
RDER71H332K0□□H03□	X7R (EIA)	50Vdc	3300pF±10%	4.0×3.5	2.5	5.0	K1	M1
RDER71H332K0□□H03□	X7R (EIA)	50Vdc	3300pF±10%	5.0×3.5	2.5	2.5	P1	S1
RDER71H472K0□□H03□	X7R (EIA)	50Vdc	4700pF±10%	4.0×3.5	2.5	5.0	K1	M1
RDER71H472K0□□H03□	X7R (EIA)	50Vdc	4700pF±10%	5.0×3.5	2.5	2.5	P1	S1
RDER71H682K0□□H03□	X7R (EIA)	50Vdc	6800pF±10%	4.0×3.5	2.5	5.0	K1	M1
RDER71H682K0□□H03□	X7R (EIA)	50Vdc	6800pF±10%	5.0×3.5	2.5	2.5	P1	S1
RDER71H103K0□□H03□	X7R (EIA)	50Vdc	10000pF±10%	4.0×3.5	2.5	5.0	K1	M1
RDER71H103K0□□H03□	X7R (EIA)	50Vdc	10000pF±10%	5.0×3.5	2.5	2.5	P1	S1
RDER71H153K0□□H03□	X7R (EIA)	50Vdc	15000pF±10%	4.0×3.5	2.5	5.0	K1	M1
RDER71H153K0□□H03□	X7R (EIA)	50Vdc	15000pF±10%	5.0×3.5	2.5	2.5	P1	S1
RDER71H223K0□□H03□	X7R (EIA)	50Vdc	22000pF±10%	4.0×3.5	2.5	5.0	K1	M1
RDER71H223K0□□H03□	X7R (EIA)	50Vdc	22000pF±10%	5.0×3.5	2.5	2.5	P1	S1
RDER71H333K0□□H03□	X7R (EIA)	50Vdc	33000pF±10%	4.0×3.5	2.5	5.0	K1	M1
RDER71H333K0□□H03□	X7R (EIA)	50Vdc	33000pF±10%	5.0×3.5	2.5	2.5	P1	S1
RDER71H473K0□□H03□	X7R (EIA)	50Vdc	47000pF±10%	4.0×3.5	2.5	5.0	K1	M1
RDER71H473K0□□H03□	X7R (EIA)	50Vdc	47000pF±10%	5.0×3.5	2.5	2.5	P1	S1
RDER71H683K0□□H03□	X7R (EIA)	50Vdc	68000pF±10%	4.0×3.5	2.5	5.0	K1	M1
RDER71H683K0□□H03□	X7R (EIA)	50Vdc	68000pF±10%	5.0×3.5	2.5	2.5	P1	S1
RDER71H104K0□□H03□	X7R (EIA)	50Vdc	0.1μF±10%	4.0×3.5	2.5	5.0	K1	M1
RDER71H104K0□□H03□	X7R (EIA)	50Vdc	0.1μF±10%	5.0×3.5	2.5	2.5	P1	S1
RDER71H154K1□□H03□	X7R (EIA)	50Vdc	0.15μF±10%	4.5×3.5	3.15	5.0	K1	M1
RDER71H154K1□□H03□	X7R (EIA)	50Vdc	0.15μF±10%	5.0×3.5	3.15	2.5	P1	S1
RDER71H224K1□□H03□	X7R (EIA)	50Vdc	0.22μF±10%	4.5×3.5	3.15	5.0	K1	M1
RDER71H224K1□□H03□	X7R (EIA)	50Vdc	0.22μF±10%	5.0×3.5	3.15	2.5	P1	S1

Continued from the preceding page.

Part Number	Temp. Char.	Rated Voltage	Capacitance	Dimensions LxW (mm)	Dimension T (mm)	Lead Space F (mm)	Lead Style Code Bulk	Lead Style Code Taping
RDER71H334K1□□H03□	X7R (EIA)	50Vdc	0.33μF±10%	4.5×3.5	3.15	5.0	K1	M1
RDER71H334K1□□H03□	X7R (EIA)	50Vdc	0.33μF±10%	5.0×3.5	3.15	2.5	P1	S1
RDER71H474K1□□H03□	X7R (EIA)	50Vdc	0.47μF±10%	4.5×3.5	3.15	5.0	K1	M1
RDER71H474K1□□H03□	X7R (EIA)	50Vdc	0.47μF±10%	5.0×3.5	3.15	2.5	P1	S1
RDER71H684K2□□H03□	X7R (EIA)	50Vdc	0.68μF±10%	5.5×4.0	3.15	2.5	P1	S1
RDER71H684K2□□H03□	X7R (EIA)	50Vdc	0.68μF±10%	5.5×4.0	3.15	5.0	K1	M1
RDER71H105K2□□H03□	X7R (EIA)	50Vdc	1.0μF±10%	5.5×4.0	3.15	2.5	P1	S1
RDER71H105K2□□H03□	X7R (EIA)	50Vdc	1.0μF±10%	5.5×4.0	3.15	5.0	K1	M1
RDER71H155K2□□H03□	X7R (EIA)	50Vdc	1.5μF±10%	5.5×4.0	3.15	2.5	P1	S1
RDER71H155K2□□H03□	X7R (EIA)	50Vdc	1.5μF±10%	5.5×4.0	3.15	5.0	K1	M1
RDER71H225K2□□H03□	X7R (EIA)	50Vdc	2.2μF±10%	5.5×4.0	3.15	2.5	P1	S1
RDER71H225K2□□H03□	X7R (EIA)	50Vdc	2.2μF±10%	5.5×4.0	3.15	5.0	K1	M1
RDER71H335K3□□H03□	X7R (EIA)	50Vdc	3.3μF±10%	5.5×5.0	4.0	2.5	P1	S1
RDER71H335K3□□H03□	X7R (EIA)	50Vdc	3.3μF±10%	5.5×5.0	4.0	5.0	K1	M1
RDEC71H475K2□□H03□	X7S (EIA)	50Vdc	4.7μF±10%	5.5×4.0	3.15	2.5	P1	S1
RDEC71H475K2□□H03□	X7S (EIA)	50Vdc	4.7μF±10%	5.5×4.0	3.15	5.0	K1	M1
RDEC71H106K3□□H03□	X7S (EIA)	50Vdc	10μF±10%	5.5×5.0	4.0	2.5	P1	S1
RDEC71H106K3□□H03□	X7S (EIA)	50Vdc	10μF±10%	5.5×5.0	4.0	5.0	K1	M1
RDEC71H226MW□□H03□	X7S (EIA)	50Vdc	22μF±20%	5.5×7.5	4.0	5.0	K1	M1
RDER72A221K0□□H03□	X7R (EIA)	100Vdc	220pF±10%	4.0×3.5	2.5	5.0	K1	M1
RDER72A221K0□□H03□	X7R (EIA)	100Vdc	220pF±10%	5.0×3.5	2.5	2.5	P1	S1
RDER72A331K0□□H03□	X7R (EIA)	100Vdc	330pF±10%	4.0×3.5	2.5	5.0	K1	M1
RDER72A331K0□□H03□	X7R (EIA)	100Vdc	330pF±10%	5.0×3.5	2.5	2.5	P1	S1
RDER72A471K0□□H03□	X7R (EIA)	100Vdc	470pF±10%	4.0×3.5	2.5	5.0	K1	M1
RDER72A471K0□□H03□	X7R (EIA)	100Vdc	470pF±10%	5.0×3.5	2.5	2.5	P1	S1
RDER72A681K0□□H03□	X7R (EIA)	100Vdc	680pF±10%	4.0×3.5	2.5	5.0	K1	M1
RDER72A681K0□□H03□	X7R (EIA)	100Vdc	680pF±10%	5.0×3.5	2.5	2.5	P1	S1
RDER72A102K0□□H03□	X7R (EIA)	100Vdc	1000pF±10%	4.0×3.5	2.5	5.0	K1	M1
RDER72A102K0□□H03□	X7R (EIA)	100Vdc	1000pF±10%	5.0×3.5	2.5	2.5	P1	S1
RDER72A152K0□□H03□	X7R (EIA)	100Vdc	1500pF±10%	4.0×3.5	2.5	5.0	K1	M1
RDER72A152K0□□H03□	X7R (EIA)	100Vdc	1500pF±10%	5.0×3.5	2.5	2.5	P1	S1
RDER72A222K0□□H03□	X7R (EIA)	100Vdc	2200pF±10%	4.0×3.5	2.5	5.0	K1	M1
RDER72A222K0□□H03□	X7R (EIA)	100Vdc	2200pF±10%	5.0×3.5	2.5	2.5	P1	S1
RDER72A332K0□□H03□	X7R (EIA)	100Vdc	3300pF±10%	4.0×3.5	2.5	5.0	K1	M1
RDER72A332K0□□H03□	X7R (EIA)	100Vdc	3300pF±10%	5.0×3.5	2.5	2.5	P1	S1
RDER72A472K0□□H03□	X7R (EIA)	100Vdc	4700pF±10%	4.0×3.5	2.5	5.0	K1	M1
RDER72A472K0□□H03□	X7R (EIA)	100Vdc	4700pF±10%	5.0×3.5	2.5	2.5	P1	S1
RDER72A682K0□□H03□	X7R (EIA)	100Vdc	6800pF±10%	4.0×3.5	2.5	5.0	K1	M1
RDER72A682K0□□H03□	X7R (EIA)	100Vdc	6800pF±10%	5.0×3.5	2.5	2.5	P1	S1
RDER72A103K0□□H03□	X7R (EIA)	100Vdc	10000pF±10%	4.0×3.5	2.5	5.0	K1	M1
RDER72A103K0□□H03□	X7R (EIA)	100Vdc	10000pF±10%	5.0×3.5	2.5	2.5	P1	S1
RDER72A153K0□□H03□	X7R (EIA)	100Vdc	15000pF±10%	4.0×3.5	2.5	5.0	K1	M1
RDER72A153K0□□H03□	X7R (EIA)	100Vdc	15000pF±10%	5.0×3.5	2.5	2.5	P1	S1
RDER72A223K0□□H03□	X7R (EIA)	100Vdc	22000pF±10%	4.0×3.5	2.5	5.0	K1	M1
RDER72A223K0□□H03□	X7R (EIA)	100Vdc	22000pF±10%	5.0×3.5	2.5	2.5	P1	S1
RDER72A333K1□□H03□	X7R (EIA)	100Vdc	33000pF±10%	4.5×3.5	3.15	5.0	K1	M1
RDER72A333K1□□H03□	X7R (EIA)	100Vdc	33000pF±10%	5.0×3.5	3.15	2.5	P1	S1
RDER72A473K1□□H03□	X7R (EIA)	100Vdc	47000pF±10%	4.5×3.5	3.15	5.0	K1	M1
RDER72A473K1□□H03□	X7R (EIA)	100Vdc	47000pF±10%	5.0×3.5	3.15	2.5	P1	S1
RDER72A683K1□□H03□	X7R (EIA)	100Vdc	68000pF±10%	4.5×3.5	3.15	5.0	K1	M1
RDER72A683K1□□H03□	X7R (EIA)	100Vdc	68000pF±10%	5.0×3.5	3.15	2.5	P1	S1
RDER72A104K1□□H03□	X7R (EIA)	100Vdc	0.1μF±10%	4.5×3.5	3.15	5.0	K1	M1
RDER72A104K1□□H03□	X7R (EIA)	100Vdc	0.1μF±10%	5.0×3.5	3.15	2.5	P1	S1
RDER72A154K2□□H03□	X7R (EIA)	100Vdc	0.15μF±10%	5.5×4.0	3.15	2.5	P1	S1
RDER72A154K2□□H03□	X7R (EIA)	100Vdc	0.15μF±10%	5.5×4.0	3.15	5.0	K1	M1
RDER72A224K1□□H03□	X7R (EIA)	100Vdc	0.22μF±10%	4.5×3.5	3.15	5.0	K1	M1
RDER72A224K1□□H03□	X7R (EIA)	100Vdc	0.22μF±10%	5.0×3.5	3.15	2.5	P1	S1

☐ Continued from the preceding page.

Part Number	Temp. Char.	Rated Voltage	Capacitance	Dimensions LxW (mm)	Dimension T (mm)	Lead Space F (mm)	Lead Style Code Bulk	Lead Style Code Taping
RDER72A334K1□□H03□	X7R (EIA)	100Vdc	0.33μF±10%	4.5×3.5	3.15	5.0	K1	M1
RDER72A334K1□□H03□	X7R (EIA)	100Vdc	0.33μF±10%	5.0×3.5	3.15	2.5	P1	S1
RDER72A474K1□□H03□	X7R (EIA)	100Vdc	0.47μF±10%	4.5×3.5	3.15	5.0	K1	M1
RDER72A474K1□□H03□	X7R (EIA)	100Vdc	0.47μF±10%	5.0×3.5	3.15	2.5	P1	S1
RDER72A684K2□□H03□	X7R (EIA)	100Vdc	0.68μF±10%	5.5×4.0	3.15	2.5	P1	S1
RDER72A684K2□□H03□	X7R (EIA)	100Vdc	0.68μF±10%	5.5×4.0	3.15	5.0	K1	M1
RDER72A105K2□□H03□	X7R (EIA)	100Vdc	1.0μF±10%	5.5×4.0	3.15	2.5	P1	S1
RDER72A105K2□□H03□	X7R (EIA)	100Vdc	1.0μF±10%	5.5×4.0	3.15	5.0	K1	M1
RDEC72A155K3□□H03□	X7S (EIA)	100Vdc	1.5μF±10%	5.5×5.0	4.0	2.5	P1	S1
RDEC72A155K3□□H03□	X7S (EIA)	100Vdc	1.5μF±10%	5.5×5.0	4.0	5.0	K1	M1
RDEC72A225K3□□H03□	X7S (EIA)	100Vdc	2.2μF±10%	5.5×5.0	4.0	2.5	P1	S1
RDEC72A225K3□□H03□	X7S (EIA)	100Vdc	2.2μF±10%	5.5×5.0	4.0	5.0	K1	M1
RDEC72A475MW□□H03□	X7S (EIA)	100Vdc	4.7μF±20%	5.5×7.5	4.0	5.0	K1	M1
RDER72E102K1□□H03□	X7R (EIA)	250Vdc	1000pF±10%	4.5×3.5	3.15	5.0	K1	M1
RDER72E152K1□□H03□	X7R (EIA)	250Vdc	1500pF±10%	4.5×3.5	3.15	5.0	K1	M1
RDER72E222K1□□H03□	X7R (EIA)	250Vdc	2200pF±10%	4.5×3.5	3.15	5.0	K1	M1
RDER72E332K1□□H03□	X7R (EIA)	250Vdc	3300pF±10%	4.5×3.5	3.15	5.0	K1	M1
RDER72E472K1□□H03□	X7R (EIA)	250Vdc	4700pF±10%	4.5×3.5	3.15	5.0	K1	M1
RDER72E682K1□□H03□	X7R (EIA)	250Vdc	6800pF±10%	4.5×3.5	3.15	5.0	K1	M1
RDER72E103K1□□H03□	X7R (EIA)	250Vdc	10000pF±10%	4.5×3.5	3.15	5.0	K1	M1
RDER72E153K1□□H03□	X7R (EIA)	250Vdc	15000pF±10%	4.5×3.5	3.15	5.0	K1	M1
RDER72E223K1□□H03□	X7R (EIA)	250Vdc	22000pF±10%	4.5×3.5	3.15	5.0	K1	M1
RDER72E333K2□□H03□	X7R (EIA)	250Vdc	33000pF±10%	5.5×4.0	3.15	5.0	K1	M1
RDER72E473K2□□H03□	X7R (EIA)	250Vdc	47000pF±10%	5.5×4.0	3.15	5.0	K1	M1
RDER72E683K2□□H03□	X7R (EIA)	250Vdc	68000pF±10%	5.5×4.0	3.15	5.0	K1	M1
RDER72E104K2□□H03□	X7R (EIA)	250Vdc	0.10μF±10%	5.5×4.0	3.15	5.0	K1	M1
RDER72E154K3□□H03□	X7R (EIA)	250Vdc	0.15μF±10%	5.5×5.0	3.15	5.0	K1	M1
RDER72E224K3□□H03□	X7R (EIA)	250Vdc	0.22μF±10%	5.5×5.0	3.15	5.0	K1	M1
RDER72E334K4□□H03□	X7R (EIA)	250Vdc	0.33μF±10%	7.5×5.5	4.0	5.0	K1	M1
RDER72E474K4□□H03□	X7R (EIA)	250Vdc	0.47μF±10%	7.5×5.5	4.0	5.0	K1	M1
RDER72E684K5□□H03□	X7R (EIA)	250Vdc	0.68μF±10%	7.5×7.5	4.0	5.0	B1	E1
RDER72E105K5□□H03□	X7R (EIA)	250Vdc	1.0μF±10%	7.5×7.5	4.0	5.0	B1	E1
RDER72E225MU□□H03□	X7R (EIA)	250Vdc	2.2μF±20%	7.7×12.5	4.0	5.0	B1	E1
RDER72J102K2□□H03□	X7R (EIA)	630Vdc	1000pF±10%	5.5×4.0	3.15	5.0	K1	M1
RDER72J152K2□□H03□	X7R (EIA)	630Vdc	1500pF±10%	5.5×4.0	3.15	5.0	K1	M1
RDER72J222K2□□H03□	X7R (EIA)	630Vdc	2200pF±10%	5.5×4.0	3.15	5.0	K1	M1
RDER72J332K2□□H03□	X7R (EIA)	630Vdc	3300pF±10%	5.5×4.0	3.15	5.0	K1	M1
RDER72J472K2□□H03□	X7R (EIA)	630Vdc	4700pF±10%	5.5×4.0	3.15	5.0	K1	M1
RDER72J682K2□□H03□	X7R (EIA)	630Vdc	6800pF±10%	5.5×4.0	3.15	5.0	K1	M1
RDER72J103K2□□H03□	X7R (EIA)	630Vdc	10000pF±10%	5.5×4.0	3.15	5.0	K1	M1
RDER72J153K2□□H03□	X7R (EIA)	630Vdc	15000pF±10%	5.5×4.0	3.15	5.0	K1	M1
RDER72J223K2□□H03□	X7R (EIA)	630Vdc	22000pF±10%	5.5×4.0	3.15	5.0	K1	M1
RDER72J333K3□□H03□	X7R (EIA)	630Vdc	33000pF±10%	5.5×5.0	3.15	5.0	K1	M1
RDER72J473K3□□H03□	X7R (EIA)	630Vdc	47000pF±10%	5.5×5.0	3.15	5.0	K1	M1
RDER72J683K4□□H03□	X7R (EIA)	630Vdc	68000pF±10%	7.5×5.5	3.15	5.0	K1	M1
RDER72J104K4□□H03□	X7R (EIA)	630Vdc	0.10μF±10%	7.5×5.5	3.15	5.0	K1	M1
RDER72J154K5□□H03□	X7R (EIA)	630Vdc	0.15μF±10%	7.5×8.0	4.0	5.0	B1	E1
RDER72J224K5□□H03□	X7R (EIA)	630Vdc	0.22μF±10%	7.5×8.0	4.0	5.0	B1	E1
RDER72J474MU□□H03□	X7R (EIA)	630Vdc	0.47μF±20%	7.7×13.0	4.0	5.0	B1	E1
RDER73A471K2□□H03□	X7R (EIA)	1000Vdc	470pF±10%	5.5×4.0	3.15	5.0	K1	M1
RDER73A681K2□□H03□	X7R (EIA)	1000Vdc	680pF±10%	5.5×4.0	3.15	5.0	K1	M1
RDER73A102K2□□H03□	X7R (EIA)	1000Vdc	1000pF±10%	5.5×4.0	3.15	5.0	K1	M1
RDER73A152K2□□H03□	X7R (EIA)	1000Vdc	1500pF±10%	5.5×4.0	3.15	5.0	K1	M1
RDER73A222K2□□H03□	X7R (EIA)	1000Vdc	2200pF±10%	5.5×4.0	3.15	5.0	K1	M1
RDER73A332K2□□H03□	X7R (EIA)	1000Vdc	3300pF±10%	5.5×4.0	3.15	5.0	K1	M1
RDER73A472K2□□H03□	X7R (EIA)	1000Vdc	4700pF±10%	5.5×4.0	3.15	5.0	K1	M1
RDER73A682K2□□H03□	X7R (EIA)	1000Vdc	6800pF±10%	5.5×4.0	3.15	5.0	K1	M1