

**PGA202/203**

## Digitally Controlled Programmable-Gain INSTRUMENTATION AMPLIFIER

### FEATURES

- DIGITALLY PROGRAMMABLE GAINS:  
DECADE MODEL—PGA202  
GAINS OF 1, 10, 100, 1000  
BINARY MODEL—PGA203  
GAINS OF 1, 2, 4, 8
- LOW BIAS CURRENT: 50pA max
- FAST SETTLING: 2μs to 0.01%
- LOW NON-LINEARITY: 0.012% max
- HIGH CMRR: 80dB min
- NEW TRANSCONDUCTANCE CIRCUITRY
- LOW COST

### APPLICATIONS

- DATA ACQUISITION SYSTEMS
- AUTO-RANGING CIRCUITS
- DYNAMIC RANGE EXPANSION
- REMOTE INSTRUMENTATION
- TEST EQUIPMENT

### DESCRIPTION

The PGA202 is a monolithic instrumentation amplifier with digitally controlled gains of 1, 10, 100, and 1000. The PGA203 provides gains of 1, 2, 4, and 8. Both have TTL or CMOS-compatible inputs for easy microprocessor interface. Both have FET inputs and a new transconductance circuitry that keeps the bandwidth nearly constant with gain. Gain and offsets are laser trimmed to allow use without any external components. Both amplifiers are available in ceramic or plastic packages. The ceramic package is specified over the full industrial temperature range while the plastic package covers the commercial range.

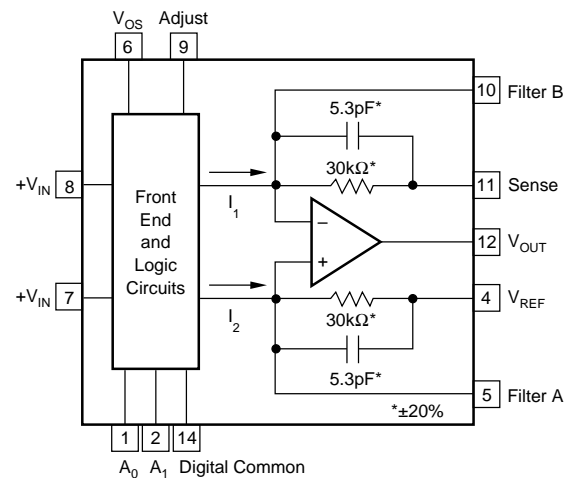

Covered by U.S. PATENT #4,883,422

International Airport Industrial Park • Mailing Address: PO Box 11400 • Tucson, AZ 85734 • Street Address: 6730 S. Tucson Blvd. • Tucson, AZ 85706  
Tel: (520) 746-1111 • Twx: 910-952-1111 • Cable: BBRCORP • Telex: 066-6491 • FAX: (520) 889-1510 • Immediate Product Info: (800) 548-6132

# SPECIFICATIONS

## ELECTRICAL

At +25°C,  $V_{CC} = \pm 15V$  unless otherwise noted.

PARAMETER	CONDITION	PGA202/203AG <sup>(1)</sup>			PGA202/203BG <sup>(1)</sup>			PGA202/203KP <sup>(1)</sup>			UNITS	
		MIN	TYP	MAX	MIN	TYP	MAX	MIN	TYP	MAX		
<b>GAIN</b> Error <sup>(2)</sup> Nonlinearity Gain vs Temperature	G < 1000		0.05	0.25		*	0.15		*	*	%	
	G = 1000		0.1	1		0.08	0.5		*	*	%	
	G < 1000		0.002	0.015		*	0.012		*	*	%	
	G = 1000		0.02	0.06		*	0.04		*	*	%	
Gain vs Temperature	G < 100		3	25		*	15		*	*	ppm/°C	
	G = 100		40	120		*	60		*	*	ppm/°C	
	G = 1000		100	300		*	150		*	*	ppm/°C	
<b>RATED OUTPUT</b> Voltage Over Specified Temperature Current Impedance	$ I_{OUT}  \leq 5mA$ See Typical Perf. Curve $ V_{OUT}  \leq 10V$	±10	±12		*	*		*	*		V	
		±5	±9		*	*		±10	*		V	
			±10		*	*		*	*		mA	
			0.5		*	*		*	*		Ω	
<b>ANALOG INPUTS</b> Common-Mode Range Absolute Max Voltage <sup>(3)</sup> Impedance, Differential Common-Mode	No Damage	±10	±13		*	*		*	*	*	V	
				± $V_{CC}$		*	*		*	*		V
			10    3 10    1			*	*		*	*		GΩ    pF GΩ    pF
<b>OFFSET VOLTAGE (RTI)</b> Initial Offset at 25°C <sup>(4)</sup> vs Temperature Offset vs Time Offset vs Supply	$10 \leq V_{CC} \leq 15$		±(0.5 + 5/G)	±(2 + 24/G)		*	±(1 + 12/G)		*	*	mV	
			±(3 + 50/G)	±(24 + 240/G)		*	±(12 + 120/G)		*	*	μV/°C	
			50			*	*			*	*	μV/Month
			10 + 250/G	100 + 900/G		*	*	50 + 450/G		*	*	μV/V
<b>INPUT BIAS CURRENT</b> Initial Bias Current: at 25°C at 85°C Initial Offset Current: at 25°C at 85°C			10	50		*	*		*	*	pA	
			640	3200		*	*		*	*	pA	
			5	25		*	*		*	*	pA	
			320	1600		*	*		*	*	pA	
<b>COMMON-MODE REJECTION RATIO</b>	G = 1	80	100		*	*		*	*		dB	
	G = 10	86	110		*	*		*	*		dB	
	G = 100	92	120		*	*		*	*		dB	
	G = 1000	94	120		*	*		*	*		dB	
<b>INPUT NOISE</b> Noise Voltage 0.1 to 10Hz Noise Density at 10kHz <sup>(5)</sup>			1.7			*			*		μVp-p nV/√Hz	
			12			*			*			
<b>OUTPUT NOISE</b> Noise Voltage 0.1 to 10Hz Density at 1kHz <sup>(5)</sup>			32			*			*		μVp-p nV/√Hz	
			400			*			*			
<b>DYNAMIC RESPONSE</b> Frequency Response Full Power Bandwidth Slew Rate Settling Time (0.01%) <sup>(7)</sup> Overload Recovery Time <sup>(7)</sup>	G < 1000		1000			*			*		kHz	
	G = 1000		250			*			*		kHz	
	G < 1000		400			*			*		kHz	
	G = 1000		100			*			*		kHz	
		10	20		15	*	*	*	*	*	V/μs	
		G < 1000	2			*	*		*	*	μs	
		G = 1000	10			*	*		*	*	μs	
	G < 1000	5			*	*		*	*	μs		
	G = 1000	10			*	*		*	*	μs		
<b>DIGITAL INPUTS</b> Digital Common Range Input Low Threshold <sup>(6)</sup> Input Low Current Input High Voltage Input High Current		- $V_{CC}$		$V_{CC} - 8$	*		*	*	*	*	V	
				0.8			*		*	*	V	
				10		*		*	*	*	μA	
		2.4		10	*		*	*	*	*	V	
				10			*	*	*	*	μA	
<b>POWER SUPPLY</b> Rated Voltage Voltage Range Quiescent Current		±6	±15	±18	*	*	*	*	*	*	V	
					*	*	*	*	*	*	V	
			6.5		*	*	*	*	*	*	mA	
<b>TEMPERATURE RANGE</b> Specification Operating Storage $\theta_{JA}$		-25		85	*		*	0		70	°C	
		-55		125	*		*	-25		85	°C	
		-65		150	*		*	-40		100	°C	
			100			*	*		*		°C/W	

\* Same as the PGA202/203AG

NOTES: (1) All specifications apply to both the PGA202 and the PGA203. Values given for a gain of 10 are the same for a gain of 8 and other values may be interpolated.

(2) Measured with a 10k load. (3) The analog inputs are internally diode clamped. (4) Adjustable to zero. (5)  $V_{NOISE(RTI)} = \sqrt{(V_{N\ INPUT})^2 + (V_{N\ OUTPUT}/Gain)^2}$ .

(6) Threshold voltages are referenced to Digital Common. (7) From input change or gain change.

## PIN CONFIGURATION

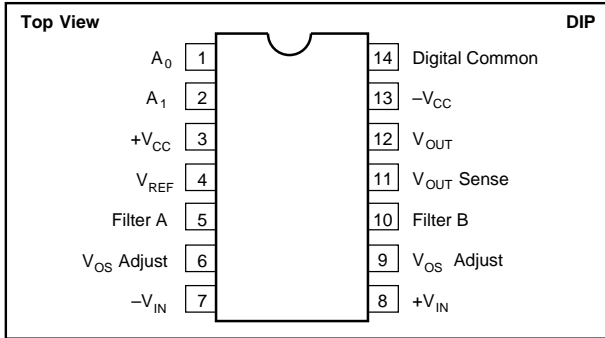

## ABSOLUTE MAXIMUM RATINGS

Supply Voltage .....	±18V
Internal Power Dissipation .....	750mW
Analog and Digital Inputs .....	±(V <sub>CC</sub> + 0.5V)
Operating Temperature Range:	
G Package .....	-55°C to +125°C
P Package .....	-40°C to +100°C
Lead Temperature (soldering, 10s) .....	300°C
Output Short Circuit Duration .....	Continuous
Junction Temperature .....	175°C

## PACKAGE INFORMATION

MODEL	PACKAGE	PACKAGE DRAWING NUMBER <sup>(1)</sup>
PGA202KP	14-Pin Plastic DIP	010
PGA202AG	14-Pin Ceramic DIP	169
PGA202BG	14-Pin Ceramic DIP	169
PGA203KP	14-Pin Plastic DIP	010
PGA203AG	14-Pin Ceramic DIP	169
PGA203BG	14-Pin Ceramic DIP	169

NOTE: (1) For detailed drawing and dimension table, please see end of data sheet, or Appendix D of Burr-Brown IC Data Book.

## ORDERING INFORMATION

MODEL	GAINS	PACKAGE	TEMPERATURE RANGE	OFFSET VOLTAGE MAX (mV)
PGA202KP	1, 10, 100, 1000	Plastic DIP	0°C to +70°C	±(2 + 24/G)
PGA202AG	1, 10, 100, 1000	Ceramic DIP	-25°C to +85°C	±(2 + 24/G)
PGA202BG	1, 10, 100, 1000	Ceramic DIP	-25°C to +85°C	±(1 + 12/G)
PGA203KP	1, 2, 4, 8	Plastic DIP	0°C to +70°C	±(2 + 24/G)
PGA203AG	1, 2, 4, 8	Ceramic DIP	-25°C to +85°C	±(2 + 24/G)
PGA203BG	1, 2, 4, 8	Ceramic DIP	-25°C to +85°C	±(1 + 12/G)

The information provided herein is believed to be reliable; however, BURR-BROWN assumes no responsibility for inaccuracies or omissions. BURR-BROWN assumes no responsibility for the use of this information, and all use of such information shall be entirely at the user's own risk. Prices and specifications are subject to change without notice. No patent rights or licenses to any of the circuits described herein are implied or granted to any third party. BURR-BROWN does not authorize or warrant any BURR-BROWN product for use in life support devices and/or systems.

# TYPICAL PERFORMANCE CURVES

$T_A = +25^\circ\text{C}$ ,  $V_S = \pm 15\text{V}$  unless otherwise noted.

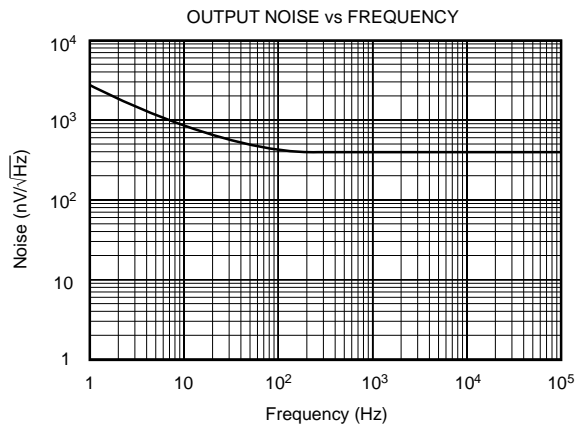
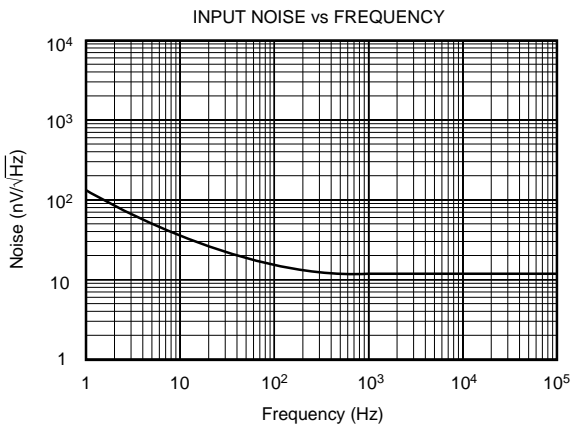
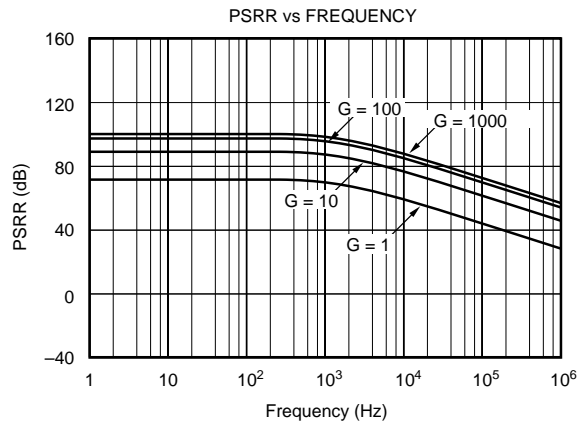
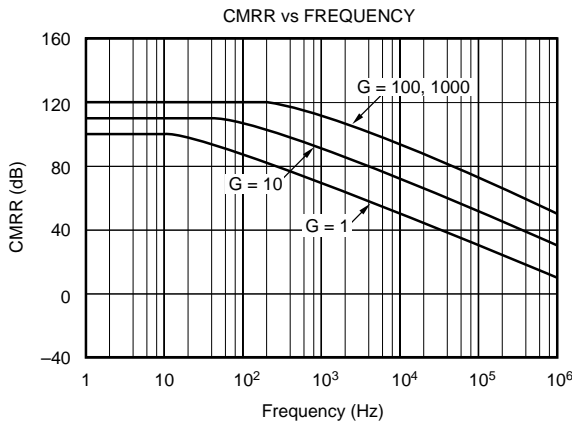
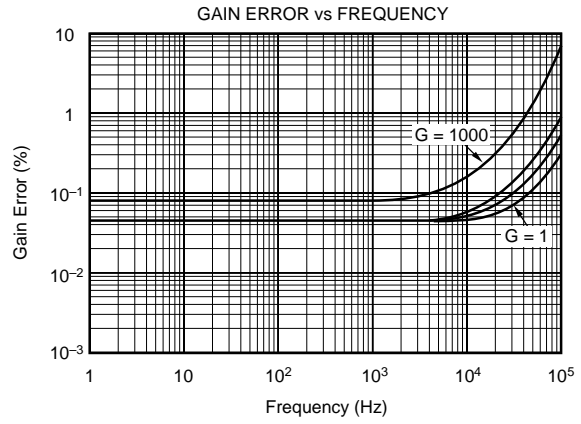
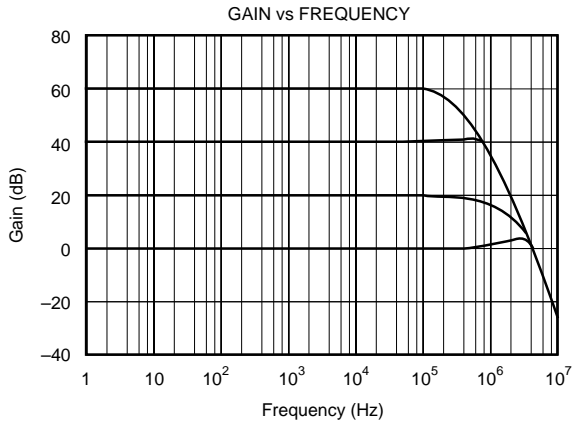

# TYPICAL PERFORMANCE CURVES (CONT)

$T_A = +25^\circ\text{C}$ ,  $V_S = \pm 15\text{V}$  unless otherwise noted.

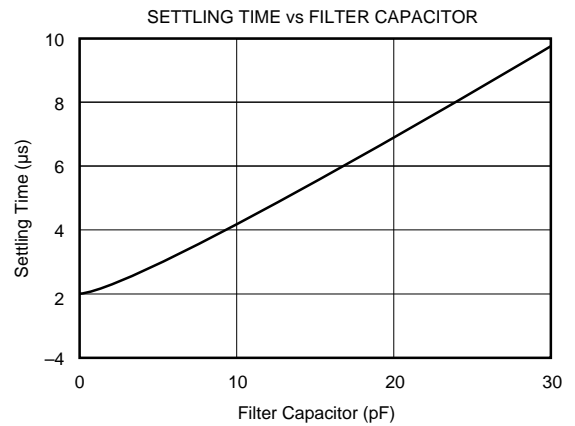
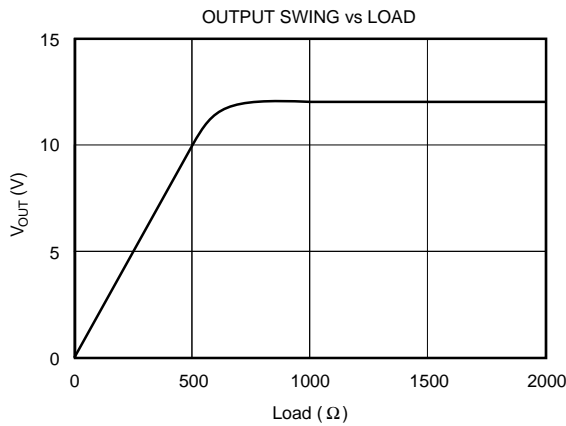
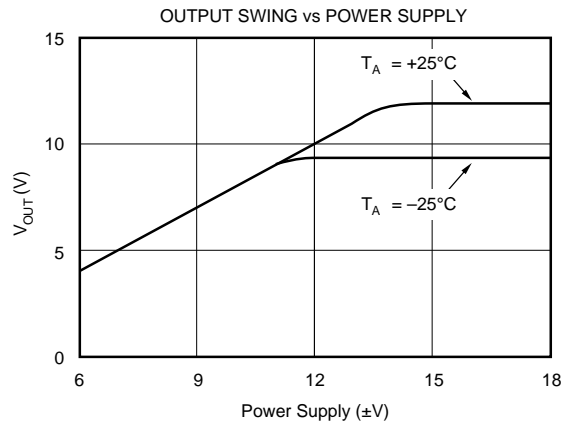
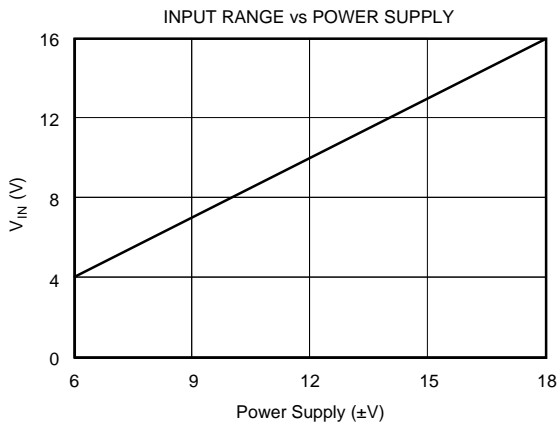
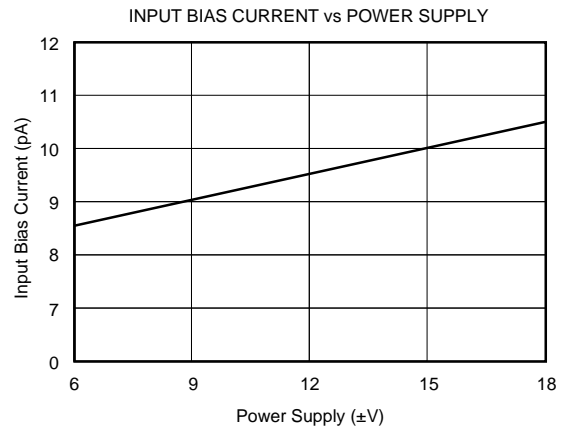
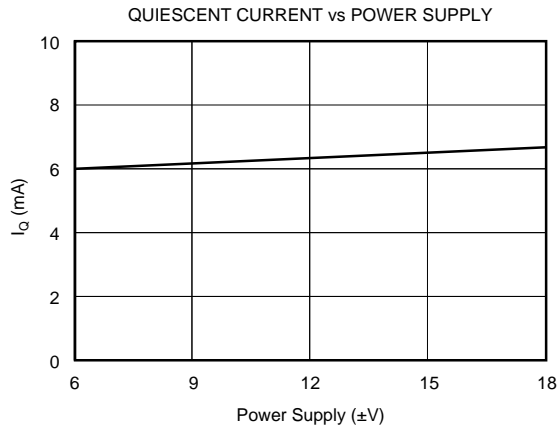

# TYPICAL PERFORMANCE CURVES (CONT)

$T_A = +25^\circ\text{C}$ ,  $V_S = \pm 15\text{V}$  unless otherwise noted.

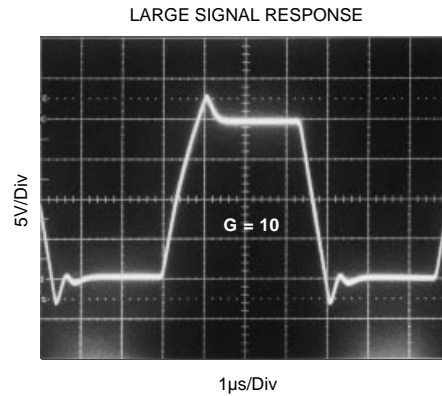
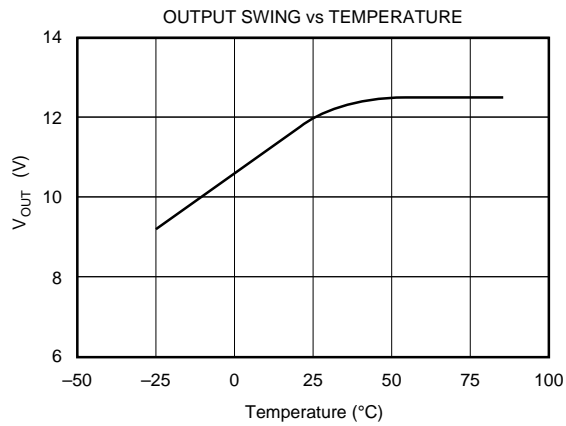
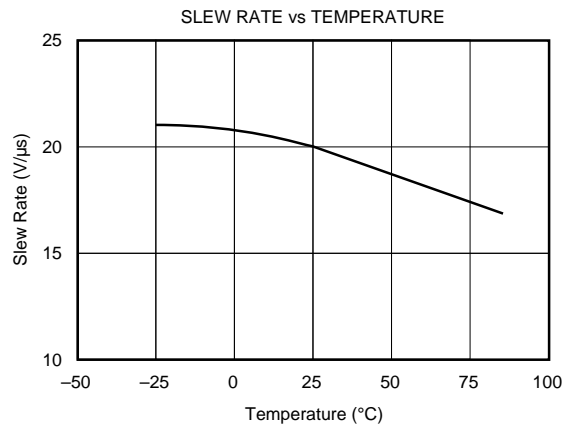
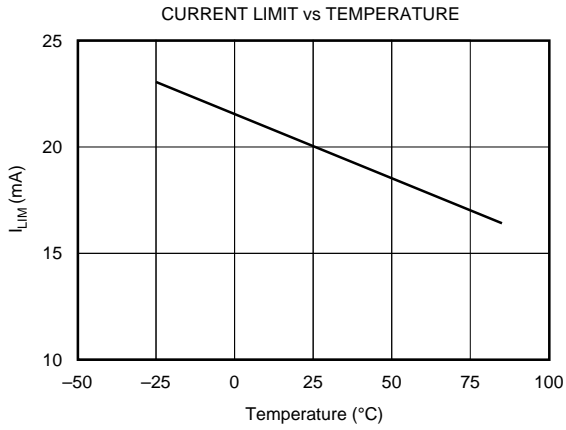
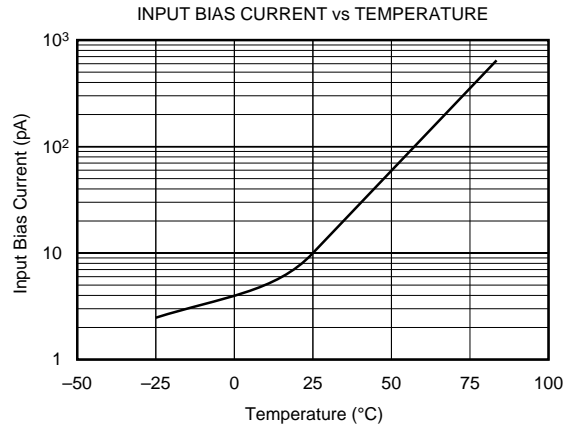
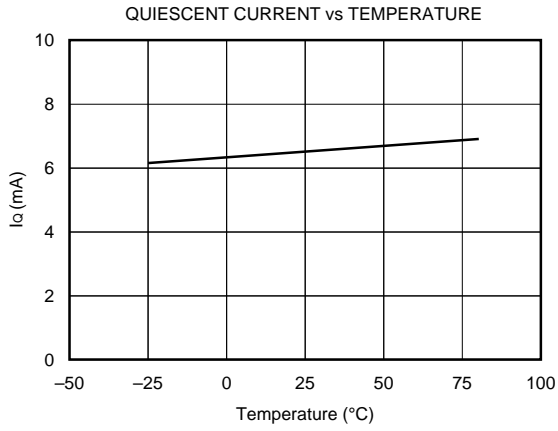

# TYPICAL PERFORMANCE CURVES (CONT)

$T_A = +25^\circ\text{C}$ ,  $V_{CC} = \pm 15\text{V}$  unless otherwise noted.

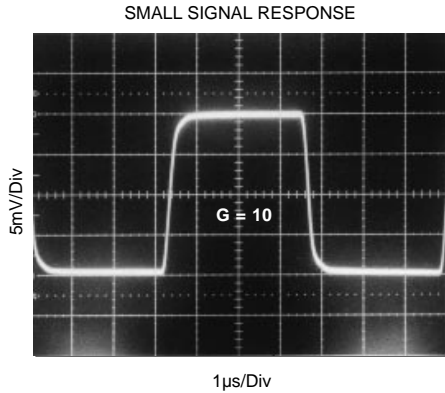

## DISCUSSION OF PERFORMANCE

A simplified diagram of the PGA202/203 is shown on the first page. The design consists of a digitally controlled, differential transconductance front end stage using precision FET buffers and the classical transimpedance output stage. Gain switching is accomplished with a novel current steering technique that allows for fast settling when changing gains. The result is a high performance, programmable instrumentation amplifier with excellent speed and gain accuracy.

The input stage uses a new circuit topology that includes FET buffers to give extremely low input bias currents. The differential input voltage is converted into a differential output current with the transconductance gain selected by steering the input stage bias current between four identical input stages differing only in the value of the gain setting resistor. Each input stage is individually laser-trimmed for input offset, offset drift, and gain.

The output stage is a differential transimpedance amplifier. Unlike the classical difference amplifier output stage, the common-mode rejection is not limited by the resistor matching. However, the output resistors are laser-trimmed to help minimize the output offset and drift.

### BASIC CONNECTIONS

Figure 1 shows the proper connections for power supply and signal. The power supplies should be decoupled with  $1\mu\text{F}$  tantalum capacitors placed as close to the amplifier as possible for maximum performance. To avoid gain and CMR errors introduced by the external components, you should connect the grounds as indicated. Any resistance in the sense line (pin 11) or the  $V_{REF}$  line (pin 4) will lead to a gain error, so these lines should be kept as short as possible. To also maintain stability, avoid capacitance from the output to the input or the offset adjust pins.

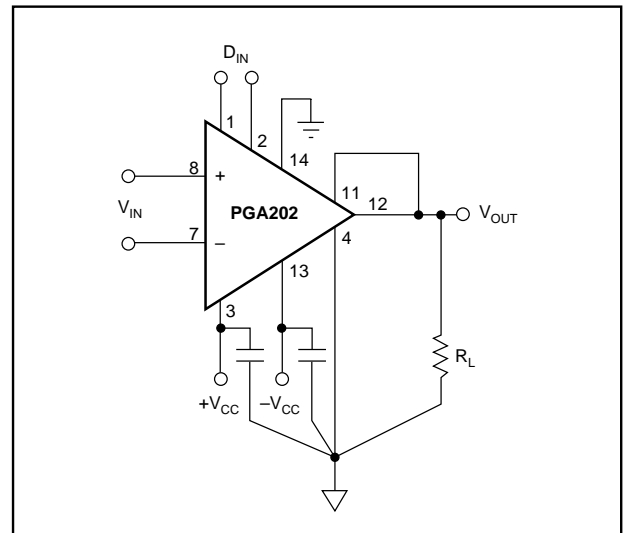

FIGURE 1. Basic Circuit Connections.

### OFFSET ADJUSTMENT

Figure 2 shows the offset adjustment circuits for the PGA202/203. The input offset and the output offset are both separately adjustable. Notice that because the PGA202/203 change between four different input stages to change gain, the input offset voltage will change slightly with gain. For systems using computer autozeroing techniques, neither offset nor drift is a major concern, but it should be noted that since the input offset does change with gain, these systems should perform an autozero cycle after each gain change for optimum performance.

In the output offset adjustment circuit, the choice of the buffering op amp is very important. The op amp needs to have low output impedance and a wide bandwidth to maintain full accuracy over the entire frequency range of the PGA202/203. For these reasons we recommend the OPA602 as an excellent choice for this application.

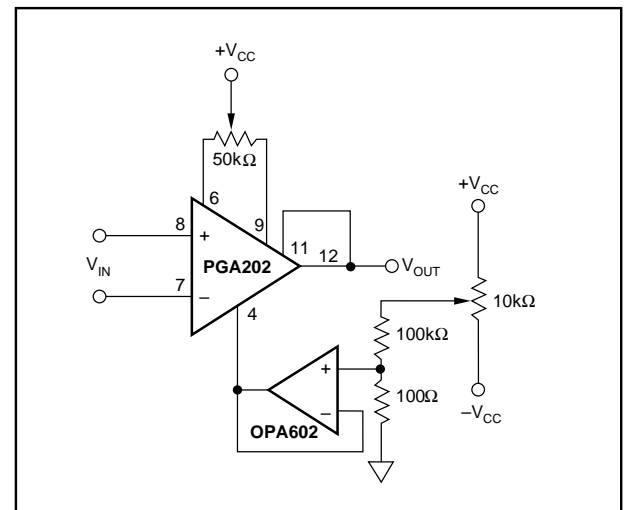

FIGURE 2. Offset Adjustment Circuits.

## GAIN SELECTION

Gain selection is accomplished by the application of a 2-bit digital word to the gain select inputs. Table I shows the gains for the different possible values of the digital input word. The logic inputs are referred to their own separate digital common pin, which can be connected to any voltage between the minus supply and 8V below the positive supply. The gains are all internally trimmed to an initial accuracy of better than 0.1%, so no external gain adjustment is required. However, if necessary the gains can be increased by the use of an external attenuator around the output stage as shown in Figure 3. Recommended resistor values for certain selected output gains are given in Table II.

		PGA202		PGA203	
A <sub>1</sub>	A <sub>0</sub>	GAIN	ERROR	GAIN	ERROR
0	0	1	0.05%	1	0.05%
0	1	10	0.05%	2	0.05%
1	0	100	0.05%	4	0.05%
1	1	1000	0.10%	8	0.05%

TABLE I. Software Gain Selection.

OUTPUT GAIN	R <sub>1</sub>	R <sub>2</sub>
2	5kΩ	5kΩ
5	2kΩ	8kΩ
10	1kΩ	9kΩ

TABLE II. Output Stage Gain Control.

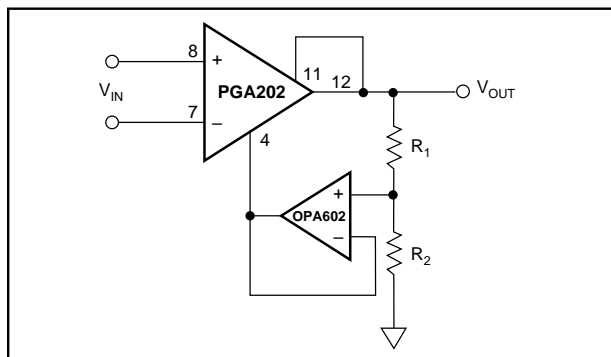

FIGURE 3. Gain Increase with Buffered Attenuator.

## COMMON-MODE INPUT RANGE

Unlike the classical three op amp type of circuit, the input common-mode range of the PGA202/203 does not depend on the differential input and the gain. In the standard three op amp circuit, the input common-mode signal must be kept below the maximum output voltage of the input amplifier minus 1/2 the final output voltage. If, for example, these amplifiers can swing  $\pm 12V$ , then to get 12V at the output you must restrict the input common-mode voltage to only 6V. The circuitry of the PGA202/203 is such that the common-mode input range applies to either input pin regardless of the output voltage.

## OUTPUT SENSE

An output sense has been provided to allow greater accuracy in connecting the load. By attaching this feedback point to the load at the load site, IR drops due to the load currents are eliminated since they are inside the feedback loop. Proper connection is shown in Figure 1. When more current is required, a power booster can be placed in the feedback loop as shown in Figure 4. Buffer errors are minimized by the loop gain of the output amplifier.

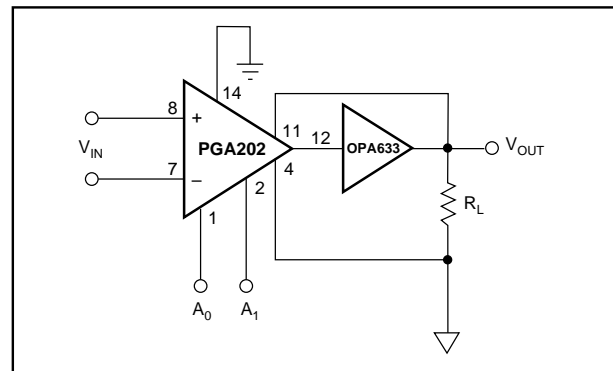

FIGURE 4. Current Boosting the Output.

## OUTPUT FILTERING

The summing nodes of the output amplifier have also been made available to allow for output filtering. By placing matched capacitors in parallel with the existing internal capacitors as shown in Figure 5, you can lower the frequency response of the output amplifier. This will reduce the noise of the amplifier, at the cost of a slower response. The nominal frequency responses for some selected values of capacitor are shown in Table III.

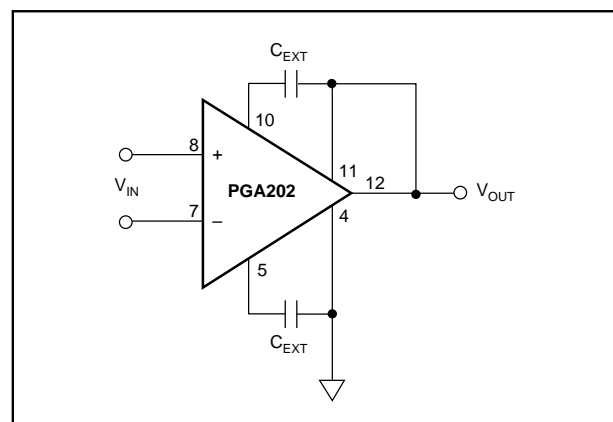

FIGURE 5. Output Filtering.

CUTOFF FREQUENCY	C <sub>1</sub> AND C <sub>2</sub>
1MHz	None
100kHz	47pF
10kHz	525pF

TABLE III. Output Frequency vs Filter Capacitors.



## INPUT CHARACTERISTICS

Because the PGA202/203 have FET inputs, the bias currents drawn through input source resistors have a negligible effect on DC accuracy. The picoamp currents produce no more than microvolts through megohm sources. The inputs are also internally diode clamped to the supplies. Thus, input filtering and input series protection are easily achievable.

A return path for the input bias currents must always be provided to prevent the charging of any stray capacitance. Otherwise, the amplifier could wander and saturate. A  $1\text{M}\Omega$  to  $10\text{M}\Omega$  resistor from the input to common will return floating sources such as thermocouples and AC-coupled inputs (see Applications Section, Figures 8 and 9.)

## DYNAMIC PERFORMANCE

The PGA202 and the PGA203 are fast-settling FET input programmable gain instrumentation amplifiers. Careful attention to minimize stray capacitance is necessary to achieve specified performance. High source resistance will interact with the input capacitance to reduce speed and overall bandwidth. Also, to maintain stability, avoid capacitance from the output to the input or the offset adjust pins.

Applications with balanced source impedance will provide the best performance. In some applications, mismatched source impedances may be required. If the impedance in the negative input exceeds that in the positive input, stray capacitance from the output will create a net negative feedback and improve the stability of the circuit. If, however, the impedance in the positive input is greater, then the feedback due to stray capacitance will be positive and instability may result. The degree of positive feedback will, of course, depend on the source impedance imbalance as well as the board layout and the operating gain. The addition of a small bypass capacitor of about 5 to 50pF directly across the input terminals of the PGIA will generally eliminate any instability arising from these stray capacitances. CMR errors due to the source imbalance will also be reduced by the addition of this capacitor.

The PGA202 and the PGA203 are designed for fast settling in response to changes in either the input voltage or the gain. The bandwidth and the settling times are mostly determined by the output stage and are therefore independent of gain, except at the highest gain of the PGA202 where other factors in the input stage begin to dominate.

## APPLICATIONS

In addition to general purpose applications, the PGA202/203 are designed to handle two important and demanding classes of applications: inputs with high source impedances, and rapid scanning data acquisition systems requiring fast settling time. Because the user has access to output sense and output common pins, current sources can also be constructed with a minimum of external components. Some basic application circuits are shown in Figures 6 through 12.

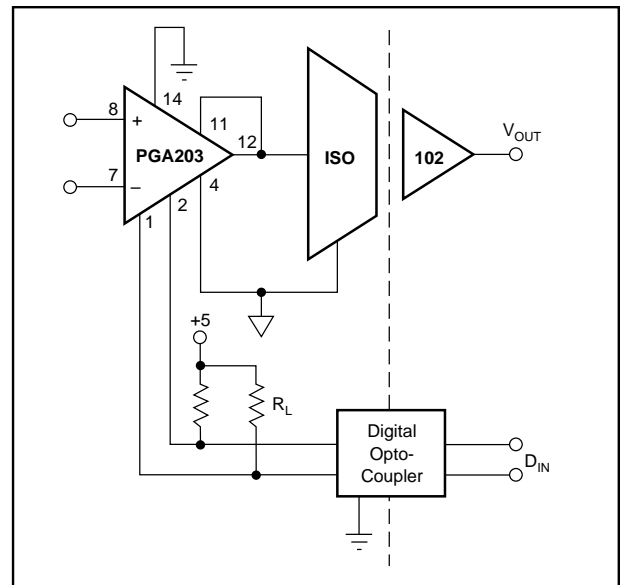

FIGURE 6. Isolated Programmable Gain Instrumentation Amplifier.

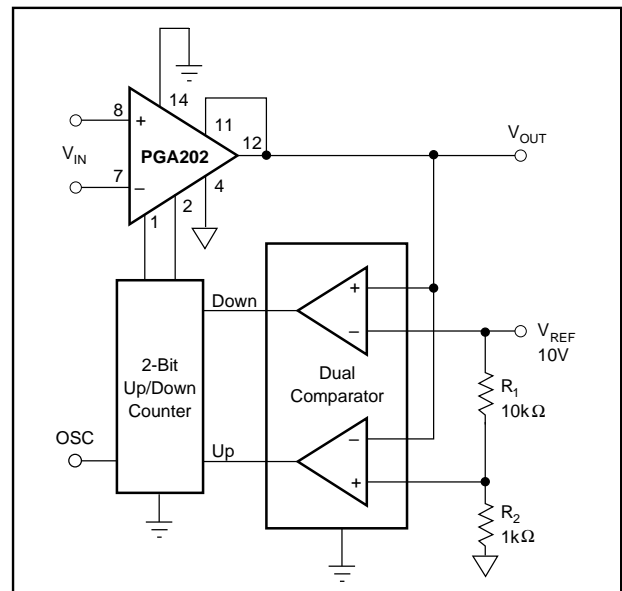

FIGURE 7. Auto Gain Ranging.

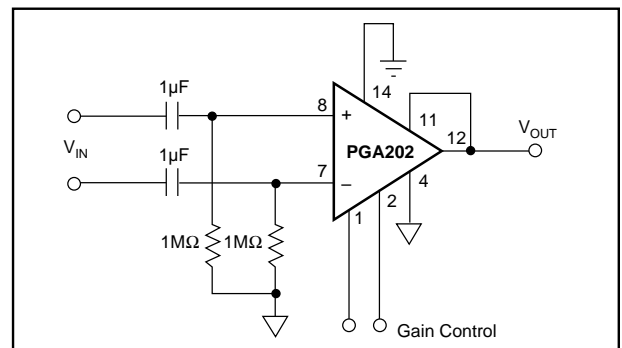

FIGURE 8. AC-Coupled Differential Amplifier for Frequencies Above 0.16Hz.

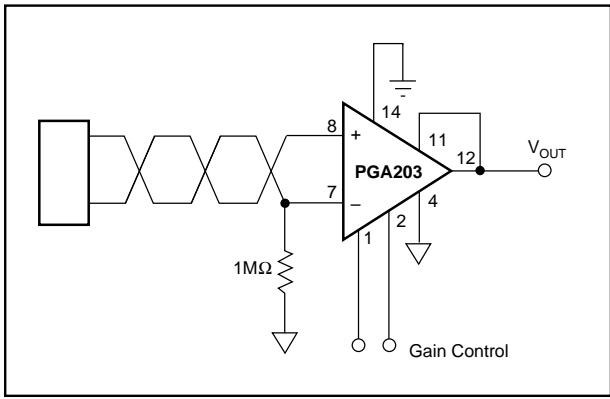

FIGURE 9. Floating Source Programmable Gain Instrumentation Amplifier.

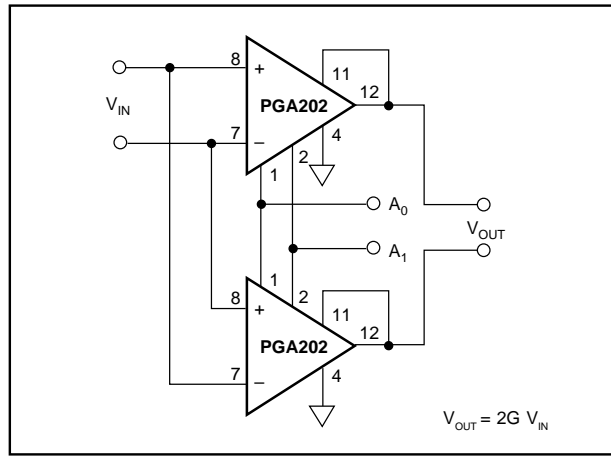

FIGURE 11. Programmable Differential In/Differential Out Amplifier.

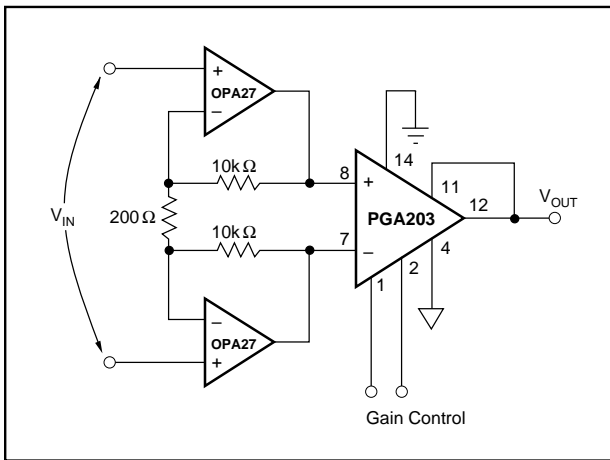

FIGURE 10. Low Noise Differential Amplifier with Gains of 100, 200, 400, 800.

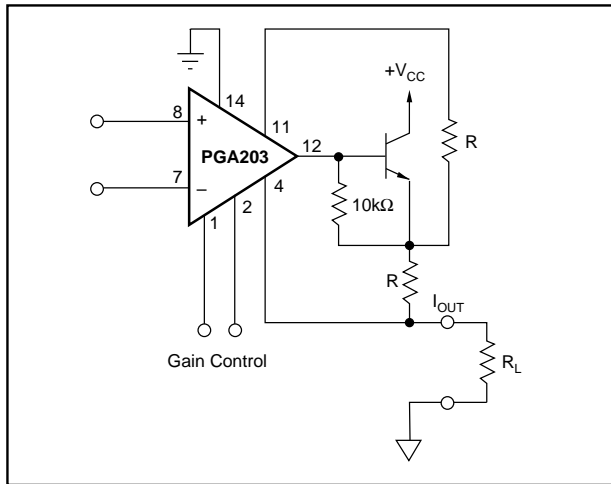

FIGURE 12. Programmable Current Source.

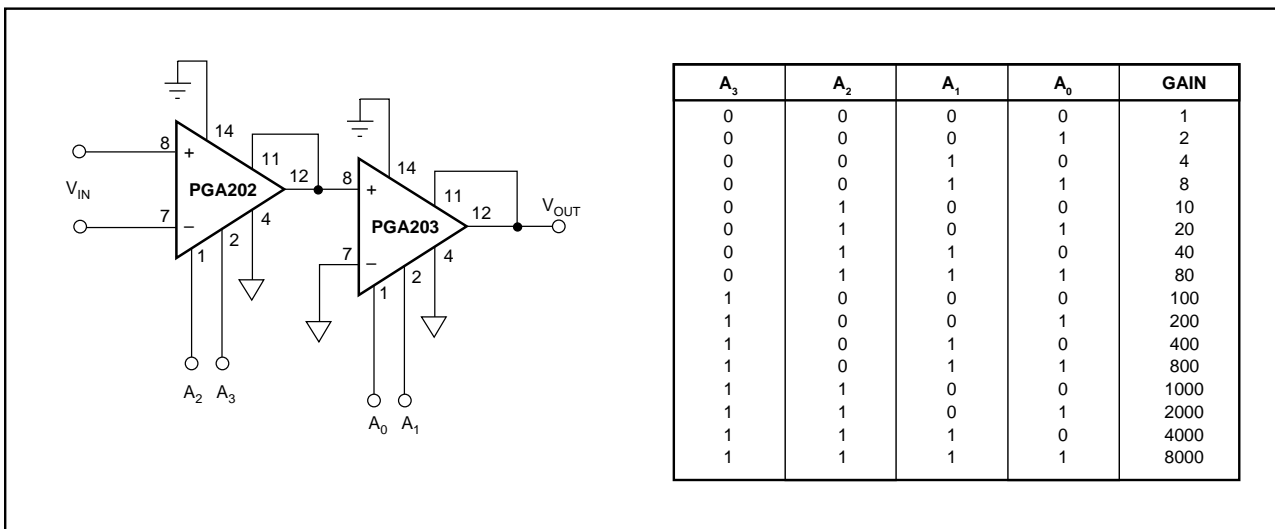

FIGURE 13. Cascaded Amplifiers.

**PACKAGING INFORMATION**

Orderable Device	Status <sup>(1)</sup>	Package Type	Package Drawing	Pins	Package Qty	Eco Plan <sup>(2)</sup>	Lead/Ball Finish	MSL Peak Temp <sup>(3)</sup>
PGA202KP	ACTIVE	PDIP	N	14	25	Green (RoHS & no Sb/Br)	CU NIPDAU	N / A for Pkg Type
PGA202KPG4	ACTIVE	PDIP	N	14	25	Green (RoHS & no Sb/Br)	CU NIPDAU	N / A for Pkg Type
PGA203KP	ACTIVE	PDIP	N	14	25	Green (RoHS & no Sb/Br)	CU NIPDAU	N / A for Pkg Type
PGA203KPG4	ACTIVE	PDIP	N	14	25	Green (RoHS & no Sb/Br)	CU NIPDAU	N / A for Pkg Type

<sup>(1)</sup> The marketing status values are defined as follows:

**ACTIVE:** Product device recommended for new designs.

**LIFEBUY:** TI has announced that the device will be discontinued, and a lifetime-buy period is in effect.

**NRND:** Not recommended for new designs. Device is in production to support existing customers, but TI does not recommend using this part in a new design.

**PREVIEW:** Device has been announced but is not in production. Samples may or may not be available.

**OBSOLETE:** TI has discontinued the production of the device.

<sup>(2)</sup> Eco Plan - The planned eco-friendly classification: Pb-Free (RoHS), Pb-Free (RoHS Exempt), or Green (RoHS & no Sb/Br) - please check <http://www.ti.com/productcontent> for the latest availability information and additional product content details.

**TBD:** The Pb-Free/Green conversion plan has not been defined.

**Pb-Free (RoHS):** TI's terms "Lead-Free" or "Pb-Free" mean semiconductor products that are compatible with the current RoHS requirements for all 6 substances, including the requirement that lead not exceed 0.1% by weight in homogeneous materials. Where designed to be soldered at high temperatures, TI Pb-Free products are suitable for use in specified lead-free processes.

**Pb-Free (RoHS Exempt):** This component has a RoHS exemption for either 1) lead-based flip-chip solder bumps used between the die and package, or 2) lead-based die adhesive used between the die and leadframe. The component is otherwise considered Pb-Free (RoHS compatible) as defined above.

**Green (RoHS & no Sb/Br):** TI defines "Green" to mean Pb-Free (RoHS compatible), and free of Bromine (Br) and Antimony (Sb) based flame retardants (Br or Sb do not exceed 0.1% by weight in homogeneous material)

<sup>(3)</sup> MSL, Peak Temp. -- The Moisture Sensitivity Level rating according to the JEDEC industry standard classifications, and peak solder temperature.

**Important Information and Disclaimer:**The information provided on this page represents TI's knowledge and belief as of the date that it is provided. TI bases its knowledge and belief on information provided by third parties, and makes no representation or warranty as to the accuracy of such information. Efforts are underway to better integrate information from third parties. TI has taken and continues to take reasonable steps to provide representative and accurate information but may not have conducted destructive testing or chemical analysis on incoming materials and chemicals. TI and TI suppliers consider certain information to be proprietary, and thus CAS numbers and other limited information may not be available for release.

In no event shall TI's liability arising out of such information exceed the total purchase price of the TI part(s) at issue in this document sold by TI to Customer on an annual basis.

## IMPORTANT NOTICE

Texas Instruments Incorporated and its subsidiaries (TI) reserve the right to make corrections, modifications, enhancements, improvements, and other changes to its products and services at any time and to discontinue any product or service without notice. Customers should obtain the latest relevant information before placing orders and should verify that such information is current and complete. All products are sold subject to TI's terms and conditions of sale supplied at the time of order acknowledgment.

TI warrants performance of its hardware products to the specifications applicable at the time of sale in accordance with TI's standard warranty. Testing and other quality control techniques are used to the extent TI deems necessary to support this warranty. Except where mandated by government requirements, testing of all parameters of each product is not necessarily performed.

TI assumes no liability for applications assistance or customer product design. Customers are responsible for their products and applications using TI components. To minimize the risks associated with customer products and applications, customers should provide adequate design and operating safeguards.

TI does not warrant or represent that any license, either express or implied, is granted under any TI patent right, copyright, mask work right, or other TI intellectual property right relating to any combination, machine, or process in which TI products or services are used. Information published by TI regarding third-party products or services does not constitute a license from TI to use such products or services or a warranty or endorsement thereof. Use of such information may require a license from a third party under the patents or other intellectual property of the third party, or a license from TI under the patents or other intellectual property of TI.

Reproduction of information in TI data books or data sheets is permissible only if reproduction is without alteration and is accompanied by all associated warranties, conditions, limitations, and notices. Reproduction of this information with alteration is an unfair and deceptive business practice. TI is not responsible or liable for such altered documentation.

Resale of TI products or services with statements different from or beyond the parameters stated by TI for that product or service voids all express and any implied warranties for the associated TI product or service and is an unfair and deceptive business practice. TI is not responsible or liable for any such statements.

Following are URLs where you can obtain information on other Texas Instruments products and application solutions:

### Products

Amplifiers	<a href="http://amplifier.ti.com">amplifier.ti.com</a>
Data Converters	<a href="http://dataconverter.ti.com">dataconverter.ti.com</a>
DSP	<a href="http://dsp.ti.com">dsp.ti.com</a>
Interface	<a href="http://interface.ti.com">interface.ti.com</a>
Logic	<a href="http://logic.ti.com">logic.ti.com</a>
Power Mgmt	<a href="http://power.ti.com">power.ti.com</a>
Microcontrollers	<a href="http://microcontroller.ti.com">microcontroller.ti.com</a>
Low Power Wireless	<a href="http://www.ti.com/lpw">www.ti.com/lpw</a>

### Applications

Audio	<a href="http://www.ti.com/audio">www.ti.com/audio</a>
Automotive	<a href="http://www.ti.com/automotive">www.ti.com/automotive</a>
Broadband	<a href="http://www.ti.com/broadband">www.ti.com/broadband</a>
Digital Control	<a href="http://www.ti.com/digitalcontrol">www.ti.com/digitalcontrol</a>
Military	<a href="http://www.ti.com/military">www.ti.com/military</a>
Optical Networking	<a href="http://www.ti.com/opticalnetwork">www.ti.com/opticalnetwork</a>
Security	<a href="http://www.ti.com/security">www.ti.com/security</a>
Telephony	<a href="http://www.ti.com/telephony">www.ti.com/telephony</a>
Video & Imaging	<a href="http://www.ti.com/video">www.ti.com/video</a>
Wireless	<a href="http://www.ti.com/wireless">www.ti.com/wireless</a>

Mailing Address: Texas Instruments  
Post Office Box 655303 Dallas, Texas 75265