

Description

- Compact footprint for high density, high current/low voltage applications
- Foil technology that adds higher reliability factor over the traditional magnet wire used for higher frequency circuit designs
- Frequency Range up to 1MHz



Applications

- Next generation microprocessors
- Energy storage applications
- DC-DC converters
- Computers

Environmental Data

- Storage temperature range: -40°C to +125°C
- Operating ambient temperature range: -40°C to +85°C (range is application specific).
- Solder reflow temperature: +260°C for 10 seconds maximum

Packaging

- 45 parts per tray bulk packaging.
- Tape and reel packaging also available, 44mm width, 110 parts per 13" reel.
- Add -TR after part number for tape and reel packaging.

Part Number	Rated Inductance μH	OCL (1) $\mu\text{H} \pm 20\%$	I _{rms} (2) Amperes (Typ.)	I _{sat} (3) Amperes (Typ.)	DCR (4) Ohms (Max.)	Volts (5) μSec
HC2-R47-R	.47	.52	52.9	63.75	.0006	6.87
HC2-R68-R	.68	.63	52.9	50.00	.0006	6.87
HC2-1R0-R	1.0	1.15	33.0	42.50	.0013	10.31
HC2-2R2-R	2.2	2.00	24.3	31.90	.0023	13.75
HC2-4R7-R	4.7	4.55	17.0	21.25	.0046	20.62
HC2-6R0-R	6.0	6.00	17.0	16.50	.0046	20.62

1) Open Circuit Inductance Test Parameters: 300kHz, 0.250 V_{rms}, 0.0 Adc
 2) DC current for an approximate temperature change of 40°C without core loss. Derating is necessary for AC currents. PCB layout, trace thickness and width, air-flow and proximity of other heat generating components will affect the temperature rise. It is recommended that the temperature of the part not exceed 125°C under worst case operating conditions verified in the end application.

3) Peak current for approximately 30% roll-off
 4) Values @ 20°C
 5) Applied Volt-Time product (V- μs) across the inductor. This value represents the applied V- μs at 300kHz necessary to generate a core loss equal to 10% of the total losses for 40°C temperature rise.

Mechanical Diagrams

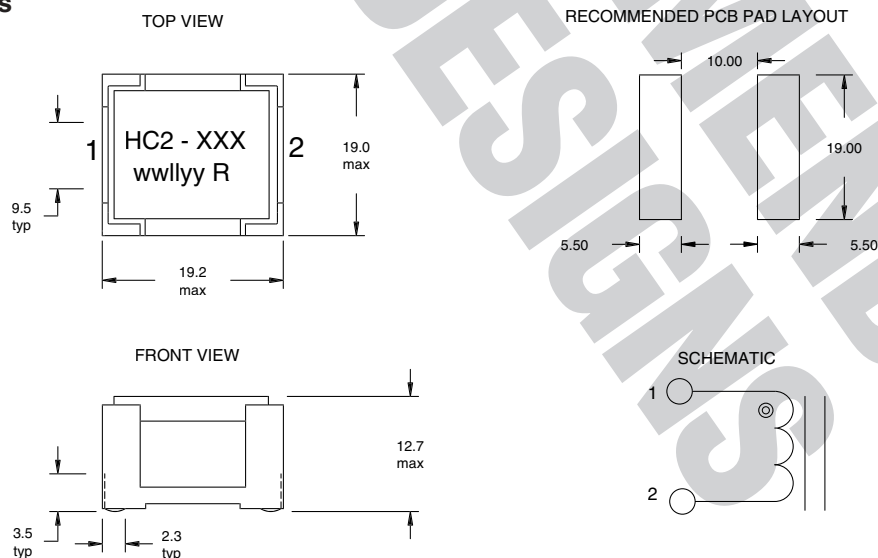

Dimensions in Millimeters

Packaging Information

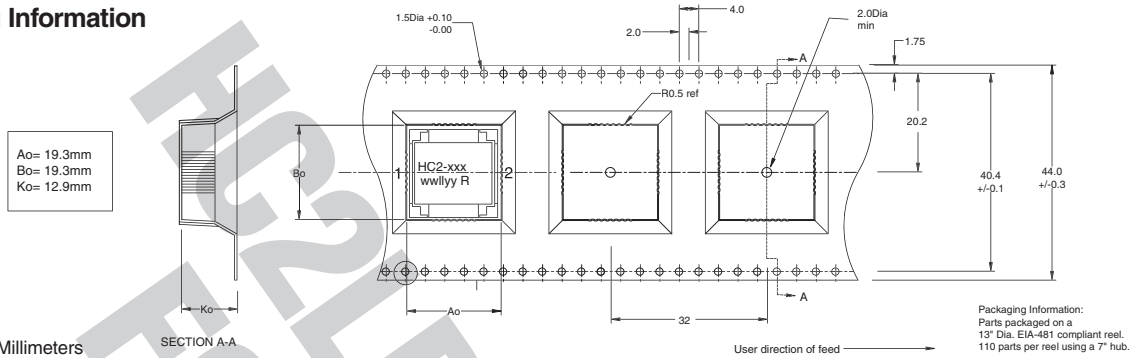

Rolloff

INDUCTANCE VERSUS SATURATION CURRENT

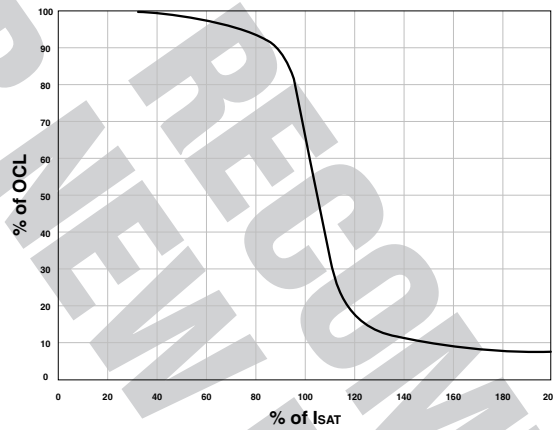

Core Loss

IRMS DERATING WITH CORE LOSS

