

PROPER USE GUIDELINES

Cumulative Trauma Disorders can result from the prolonged use of manually powered hand tools. AMP hand tools are intended for occasional use and low volume applications. AMP offers a wide selection of powered application equipment for extended-use, production operations.

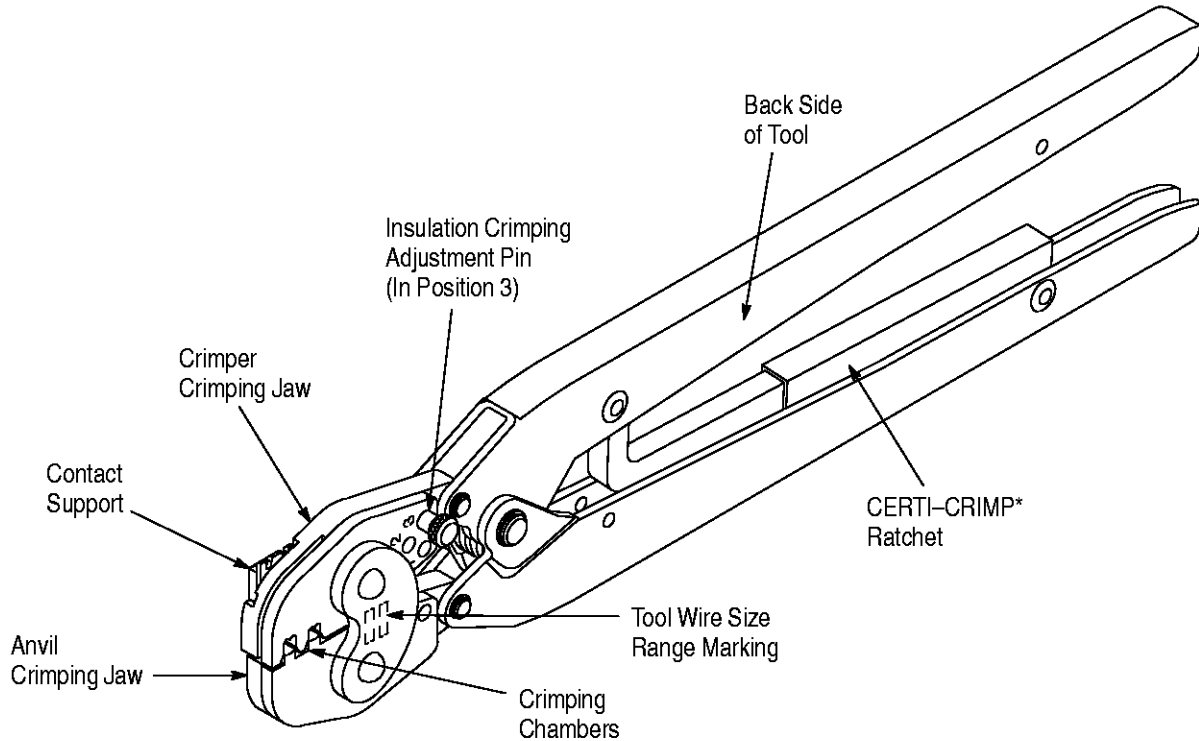

Figure 1

1. INTRODUCTION

AMP* Hand Crimping Tools 90123-2, 90123-5, and 90124-2 are designed to crimp AMP MATE-N-LOK* pin and socket contacts onto wire size range of 24 to 14 AWG with an insulation diameter range of 1.09 to 3.30 mm [.043 to .130 in.]. Read these instructions thoroughly before using the hand tool.

NOTE *Measurements are in millimeters [followed by inch equivalents in brackets]. Figures are for identification only and are not drawn to scale.*

Reasons for reissue are provided in Section 7, REVISION SUMMARY.

2. DESCRIPTION

The hand tool features two crimping jaws (anvil and crimper), an insulation crimping adjustment pin, contact support, locator/insulation stop, and a CERTI-CRIMP ratchet. When closed, the jaws form two crimping chambers, each marked on the BACK side of the tool with the wire size range. The tool wire size range is marked on the link. See Figure 1.

The locator/insulation stop positions the contact between the crimping jaws and aids in locating the wire in the contact. In use, it rests in the contact locator slot. The contact support prevents the contact from bending during the crimping operation.

The insulation crimping adjustment pin is used to regulate the crimp height of the contact insulation barrel. The CERTI-CRIMP ratchet ensures full crimping of the contact. Once engaged, the ratchet will not release until the tool handles have been FULLY closed.

CAUTION *The crimping jaws bottom before the CERTI-CRIMP ratchet releases. This design feature ensures maximum electrical and tensile performance of the crimp. Do NOT re-adjust the ratchet.*

3. CRIMPING PROCEDURE

Refer to Figure 2 and select the appropriate wire size and contact for the hand tool. The wire size and insulation diameter must be within the specified range for the contact. Strip the wire to the length indicated in Figure 2. Do NOT nick or cut the wire strands.

Typical MATE-N-LOK Contacts

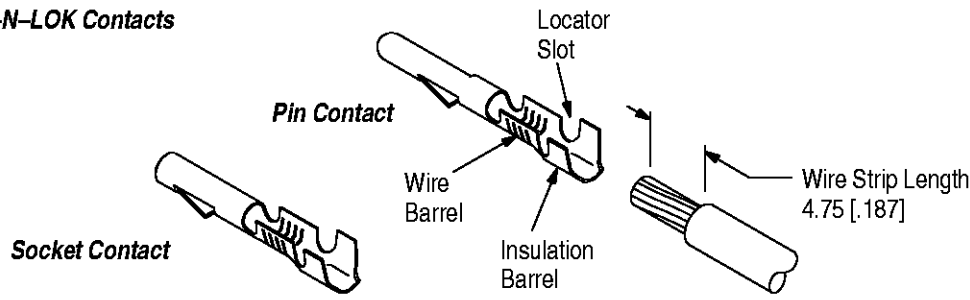

WIRE		CONTACT		HAND TOOL	
SIZE	INSULATION DIAMETER	PIN	SOCKET	PART NUMBER	MARKING
24-20	1.09-1.91 [.043-.075]	60618-[-]	60617-[-]	90123-5	B
	1.52-2.54 [.060-.100]	—	61473-[-]	90123-2	
20-14	2.54-3.30 [.100-.130]	60620-[-]	60619-[-]	90124-2	20-14
18	1.52-2.54 [.060-.100]	60618-[-]	60617-[-]	90123-5	A
		—	61473-[-]	90123-2	

Figure 2

One end of the contact support is marked for pin contacts and the other end for socket contacts. Change it to the appropriate setting by lifting the support and rotating it 180° until the support is properly seated in the groove of the tool (refer to Figure 3) Then proceed as follows:

1. Hold tool so that the BACK side is facing you.
2. Open the jaws by squeezing the tool handles together until the CERTI-CRIMP ratchet releases.

3. Insert the contact insulation barrel from the FRONT side of the tool into the appropriate crimping chamber. Position the contact on the anvil crimping jaw so that the locator enters the contact locator slot. See Figure 3.

4. Holding the contact in place, squeeze the tool handles together until the anvil starts entry into the crimper.

CAUTION Do NOT deform the insulation barrel or wire barrel.

5. Insert stripped wire through the wire slot in the locator and into the contact wire barrel until the insulation butts against the locator/insulation stop.

6. Holding wire in place, squeeze tool handles together until CERTI-CRIMP ratchet releases.

7. Allow tool handles to open FULLY and remove crimped contact from tool.

8. Inspect the crimp according to Figure 4. For detailed information on crimp inspection, refer to AMP Application Specification 114-1012.

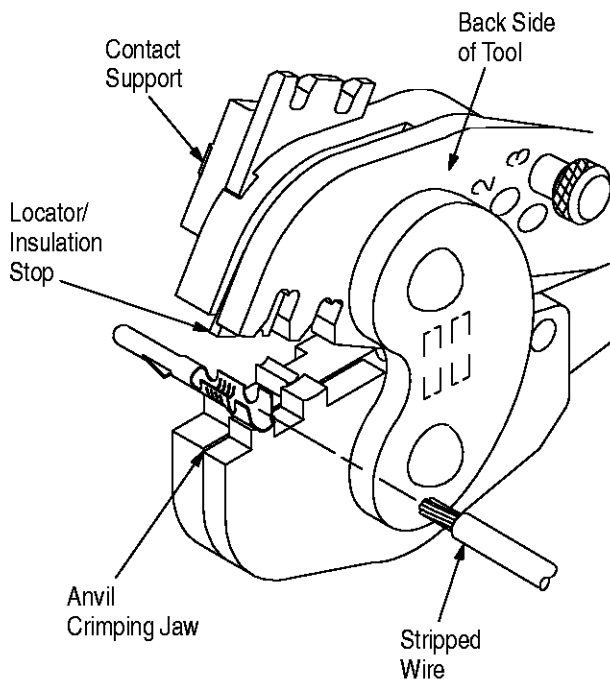

Figure 3

4. INSULATION CRIMP ADJUSTMENT

The hand tool has three insulation adjustment positions to adjust the wire insulation grip: 1—Tight, 2—Medium, and 3—Loose. To determine the proper insulation crimp setting, proceed as follows:

1. Insert adjustment pin into Position 3, as shown in Figure 1.
2. Position contact into crimping jaws as described in Section 3, CRIMPING PROCEDURE.

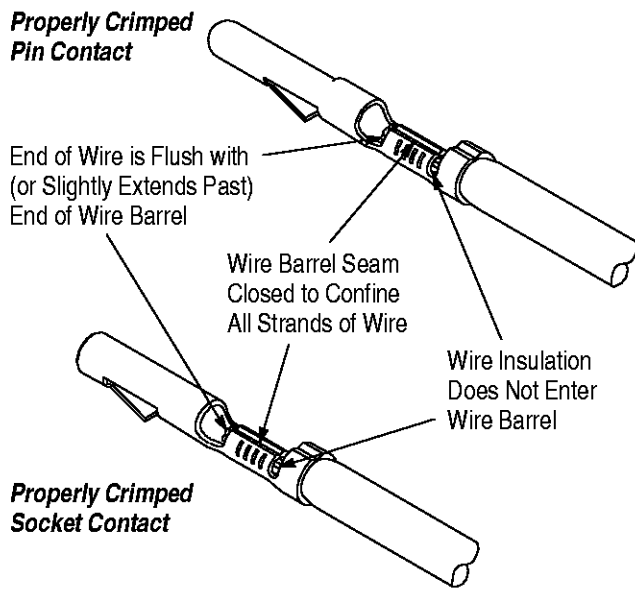

Figure 4

3. Insert UNSTRIPPED wire into just the contact insulation barrel. Crimp contact and remove from crimping jaws.

4. Check the insulation support by bending the wire back and forth once. The insulation barrel should retain grip on the wire insulation. If the wire pulls out, move the insulation adjustment pin to the next tighter position and perform another test crimp. If the wire does not pull out, the pin is properly adjusted and the tool is ready for crimping. Do not use a tighter crimp than necessary.

NOTE *Adjust pin, as necessary, until the desired insulation grip is obtained. Crimp should hold wire insulation firmly without cutting into it.*

5. MAINTENANCE AND INSPECTION PROCEDURE

AMP recommends that a maintenance and inspection program be performed periodically to ensure dependable and uniform terminations. Though recommendations call for at least one inspection a month, frequency of inspection depends on:

1. The care, amount of use, and handling of the hand tool.
2. The presence of abnormal amounts of dust and dirt.
3. The degree of operator skill.
4. Your own established standards.

The hand tool is inspected before being shipped; however, AMP recommends that the tool be inspected immediately upon arrival to ensure that the tool has not been damaged during shipment.

5.1. Daily Maintenance

1. Hand tool should be immersed (handles partially closed) in a reliable commercial degreasing compound to remove accumulated dirt, grease, and foreign matter. When degreasing compound is not available, tool may be wiped clean with a soft, lint-free cloth. Do NOT use hard or abrasive objects that could damage the tool.
2. Make certain that the retaining pins are in place and that they are secured with retaining rings.
3. All pins, pivot points, and bearing surfaces should be protected with a THIN coat of any good SAE 20 motor oil. Do not oil excessively.
4. When the tool is not in use, keep handles closed to prevent objects from becoming lodged in the crimping jaws. Store the tool in a clean, dry area.

5.2. Periodic Inspection

A. Lubrication

Lubricate all pins, pivot points, and bearing surfaces with SAE 20 motor oil as follows:

- Tool used in daily production—lubricate daily
- Tool used daily (occasional)—lubricate weekly
- Tool used weekly—lubricate monthly

Wipe excess oil from tool, particularly from crimping area. Oil transferred from the crimping area onto certain terminations may affect the electrical characteristics of an application.

B. Visual Inspection

1. Close tool handles until ratchet releases and then allow them to open freely. If they do not open quickly and fully, the spring is defective and must be replaced. See Section 6, REPLACEMENT AND REPAIR.
2. Inspect head assembly for worn, cracked, or broken jaws. If damage is evident, return the tool to AMP for evaluation and repair. See Section 6, REPLACEMENT AND REPAIR.

C. Crimp Height Inspection

This inspection requires the use of a modified micrometer with a modified anvil and spindle, as shown in Figure 5. AMP recommends the Crimp Height Comparator RS-1019-5LP which can be purchased from:

Shearer Industrial Supply Co. VALCO
20 North Penn Street or 1410 Stonewood Drive
York, PA 17401-1014 Bethlehem, PA 18017-3527

Proceed as follows:

1. Select a contact and *maximum* size wire for each crimping chamber.

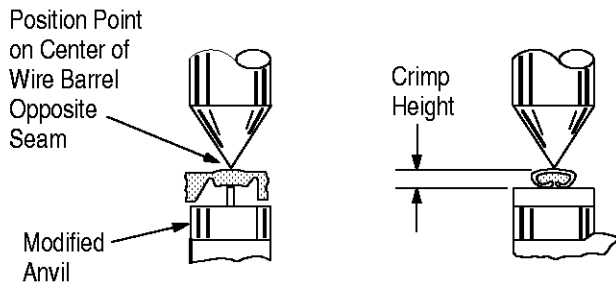

HAND TOOL	WIRE SIZE (AWG) (Max)	CRIMP HEIGHT DIMENSION (± 0.05 [$\pm .002$])
90123-2	18	1.24 [.049]
90123-5	20	0.99 [.039]
90124-2	14	1.35 [.053]

Figure 5

2. Refer to Section 3, CRIMPING PROCEDURE, and crimp contact accordingly.

3. Using a crimp height comparator, measure the wire barrel crimp height as shown in Figure 5. If the crimp height conforms to that height, the tool is considered dimensionally correct. If not, the tool must be returned to AMP for evaluation and repair. See Section 6, REPLACEMENT AND REPAIR.

For additional information concerning the use of the crimp height comparator, refer to AMP instruction sheet 408-7424.

D. CERTI-CRIMP Ratchet Inspection

The CERTI-CRIMP ratchet feature on AMP hand tools should be checked to ensure that the ratchet does not release prematurely, allowing the jaws to open before they have fully bottomed. Obtain a 0.025 [.001] shim that is suitable for checking the clearance between the bottoming surfaces of the crimping jaws and proceed as follows:

1. Select a contact and *maximum* size wire for the hand tool.

2. Position the contact and wire between the crimping jaws, as described in Section 3, CRIMPING PROCEDURE.

3. Holding the wire in place, squeeze the handles until the CERTI-CRIMP ratchet releases. Hold the handles in this position, maintaining just enough tension to keep the jaws closed.

4. Check the clearance between the bottoming surfaces of the crimping jaws. If the clearance is 0.025 [.001] or less, the ratchet is satisfactory. If clearance exceeds 0.025 [.001], the ratchet is out of adjustment and must be repaired. See Section 6, REPLACEMENT AND REPAIR.

6. REPLACEMENT AND REPAIR

The parts listed in Figure 6 are customer-replaceable. A complete inventory can be stocked and controlled to prevent lost time when replacement of parts is necessary. Order replacement parts through your AMP representative, or call 1-800-526-5142, or send a facsimile of your purchase order to 717-986-7605, or write to:

CUSTOMER SERVICE (38-35)
 AMP INCORPORATED
 PO BOX 3608
 HARRISBURG PA 17105-3608

Tools may also be returned to AMP for evaluation and repair. For tool repair service, contact an AMP representative at: 1-800-526-5136.

7. REVISION SUMMARY

The following changes were made since the previous release of this sheet:

Per EC 0990-0725-99

- Changed tool repair service information in Section 6, REPLACEMENT AND REPAIR
- Updated document format

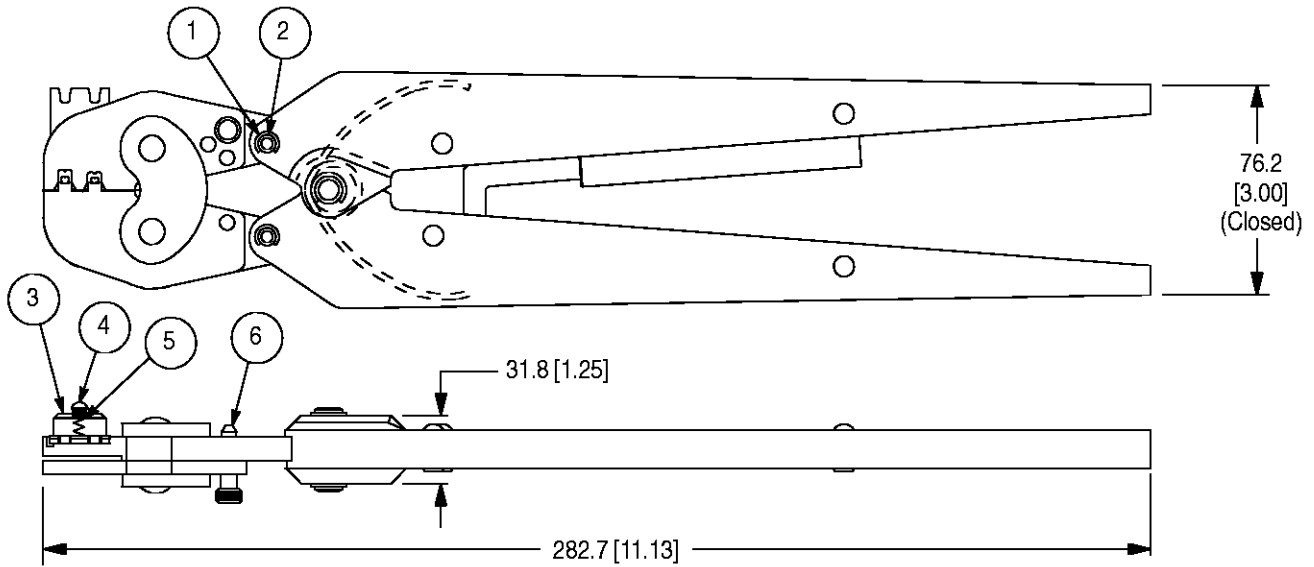

Weight: 624 g [1 lb 6 oz]

REPLACEMENT PARTS

ITEM	PART NUMBER	DESCRIPTION	QTY PER TOOL
1	21045-3	RING, External Crescent Retaining, .188 D Shaft	4
2	8-59558-2	PIN, Retaining, .187 D x .521 L	2
3	318766-1	SUPPORT, Contact	1
4	125529-5	SCREW, Shoulder	1
5	22280-1	SPRING, Compression	1
6	39207	ADJUSTMENT PIN	1

Figure 6